

2025 | 2026

 **LANG**
TECHNIK
simple. gripping. future.

Contents

Preface	3
New products	4
About LANG Technik	6
Everything revolves around your workpiece	8
Zero point clamping	10
Quick·Point® zero point clamping system	14
Quick·Tower tombstone	58
Quick·Point® Rail quick clamping system	80
Workholding	92
Makro·Grip® stamping technology	96
Makro·Grip® 5-axis vise	118
Makro·4Grip clamping jaws for round part clamping	148
Avanti clamping jaws for contour clamping	156
Profilo clamping jaws for contour clamping	164
Vario·Tec clamping jaws with support and end stop system	170
Vasto·Clamp 6-jaw chuck	174
Preci·Point collet chuck	182
Makro·Grip® Ultra	188
Automation	212
RoboTrex automation system	216
RoboTrex Compact automation system	240
Haubex automation system	250
Clean·Tec chip fan	260
Online store, brand store	268
Imprint, terms and conditions	270



Dear reader,

We are pleased to present you with our new complete catalog from LANG Technik. In recent years, we have worked hard to expand and optimize our product range in order to offer you the best possible solutions for your manufacturing and process requirements.

In this catalog, we combine our three main pillars: zero point clamping technology, workholding technology and machine tool automation. These three areas form a comprehensive and coherent package that helps you to make your machining processes more efficient and economical.

Our zero point clamping technology allows you to quickly and precisely position your clamping fixtures, while our workholding technology offers a wide range of options for securely gripping any component shape. This is complemented by our innovative solutions for the automation of machine tools, which help you to shorten production times and increase efficiency.

We are convinced that the combination of these technologies will not only help you to optimize your production processes, but also to increase your competitiveness. Our goal is to be at your side as a partner and to work with you to meet the challenges of modern manufacturing.

We thank you for your trust in LANG Technik and hope you enjoy discovering our products and solutions.

Kind regards,

Philipp Lang & Patrizio De Pinto

Managing directors of LANG Technik

New products

We are pleased to present our new products, which have been added to our range since the release of our last catalog.

RoboTrex Compact automation system

→ p. 240



Even more space-saving, even more vises on a small footprint, even more cost-efficient. The new RoboTrex Compact automation system combines all the advantages of its “big brother”, but is specially designed for applications in the small component range. The integrated Fanuc robot transports components up to 7 kg from the

storage rack to the machine tool and back. The storage rack of the vise handling system can hold up to 100 Makro-Grip® 46 Micro vises or 50 Makro-Grip® 77 vises. This provides excellent potential for generating additional unmanned spindle hours and thus increasing productivity in manufacturing.

Makro-Grip® 46 Micro 5-axis vise

→ p. 124



“Small but powerful” – this is the best way to describe the new Makro-Grip® 46 Micro. This vise is a real space saver and perfect for clamping several small components in a small space. The new Quick-Point® 52 Duo series is available to match. What makes it

special? A compact base body with only two clamping studs allows two 5-axis vises to be clamped side by side on a zero point plate. This combination of compactness and holding force also makes the vise ideal for the automation of small components.

Quick·Point® Rail quick clamping system

→ p. 80

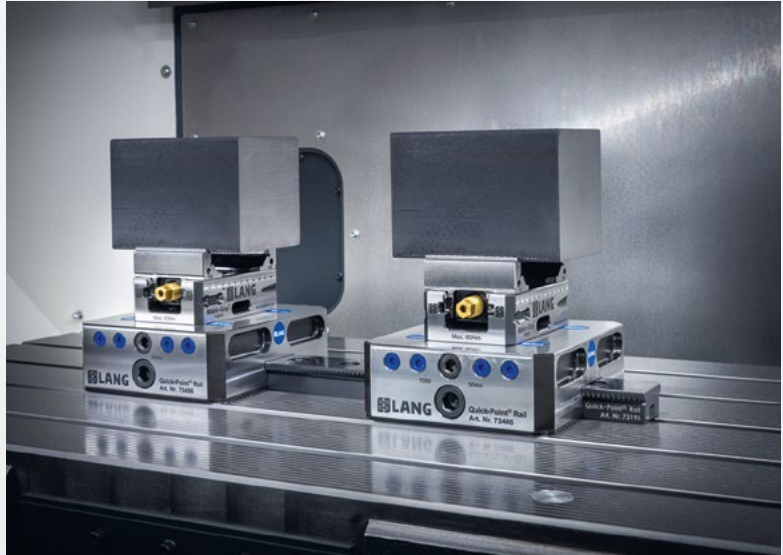

The innovative quick clamping system for machine tables and automation pallets offers a customized solution for companies that want to save time on set-up and minimize installation times. With its versatility and optimal cost efficiency, the clamping system is convincing in every aspect. In particular, when used on pallet

automation systems, large 3-axis tables and trunnions, it leads to significant cost savings because it does not require a zero point base plate. The speed and flexibility when setting up are also an unbeatable advantage with Quick·Point® Rail!

Makro·Grip® FS clamping technology

→ p. 144



More performance and clamping power during milling! The new, continuous “full serration” is particularly useful for soft and tough materials and components with a small clamping surface. Users benefit from up to 60% higher holding force. Makro·Grip® FS is

available as an additional clamping jaw version for the 5-axis vise and in a new version for the revised stamping units. With the improved “original” workpieces can be clamped at the highest level of safety!

This is LANG! Made in Germany – at home worldwide

LANG Technik has over 40 years of experience in machining. We started out as a contract manufacturer, but since 1997 we have been developing our own product solutions, always true to the motto “Made in Germany”. Since then, numerous patents and trend-setting innovations have followed. Today, our family business is one of the global market leaders in workholding and automation technology. Our stance of “Made in Germany” strongly encompasses our deep belief of delivering consistent, high quality and reliable solutions to our customers around the world.

> 30,000

VICES ARE MANUFACTURED AND DELIVERED ANNUALLY

> 500

INNOVATIVE PRODUCTS

LANG Technik USA Co.



→ LANG Technik USA
New company building in 2025

LANG Technik GmbH

LANG Technik
France SAS

LANG Technik Schweiz AG

43

EXCLUSIVE SALES PARTNERS
WORLDWIDE

NEW: ARGENTINA, BRASIL,
CHILE, MEXICO

OUR MISSION

As a pioneer in this industry, we develop and produce integrated solutions in the field of automation, zero point clamping and workholding for both ourselves and for all machining industry sectors.

OUR VISION

Giving every machining company worldwide access to innovative and flexible workholding solutions, simplifying their processes, reducing costs and guaranteeing consistent quality.



→ LANG Technik Headquarters in Germany
Planned expansion in 2025 / 2026

> 150

EMPLOYEES AT FIVE
DIFFERENT LOCATIONS

MAIN PRODUCT GROUPS

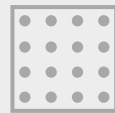

Zero point
clamping



Workholding



Automation

SOLUTIONS FOR ANY APPLICATION

Companies of all sizes, from 1-man-operation to global players, from various industries trust our vast experience and innovative strength.

- Engineering → Medical → Aerospace → Automotive / Racing → Power Generation → Defense → Food Industry
- Precision Engineering → Schools → Universities
- Research Institutes → and many more

innovative. original. pioneering.

Everything revolves around your workpiece

We at LANG Technik are aware of this and have designed our **workholding technology** to provide you with the ideal conditions for milling your perfect workpiece. No matter what the shape of the component or the machining phase, we have a solution for you. Cuboid, cylindrical or round. First or second clamping operation – often your workpiece can be completely finished in a single clamping operation. From the machining of raw parts using stamping technology as today's benchmark in the industry to the finished part. From delicate components to large plates. Our workholding solutions cover every need. Another advantage: the modular composition of our systems. With LANG Technik, you are guaranteed cost-effective manufacturing to produce your perfectly finished workpiece.

The processes around the actual machining are also very important to us. If you know us, you know that we make our products to be

easy and fast. Setup times play a crucial role for us and our goal is to keep them as low as possible. Not only for our own production, but also for you so that you can get more out of your milling machine and let the chips fly. That's why we have quick clamping and **zero point clamping systems** that can be used universally and are suitable for almost every machine table or automation pallet.

Speaking of: **Automation**. This is your biggest key for more efficiency and a decisive factor for your competitiveness. We are also excellently positioned in this area because our automation systems are also universally applicable. They are easy to use, give you maximum flexibility in production management and are also attractively priced. More output, shorter production times, better prices. Our automation systems are your production boosters.

Explanation of symbols

	cylindrical parts		Makro-Grip®		Avanti
	cuboid parts		Makro-Grip® Ultra		Profilo
	pre-machined parts		Vasto-Clamp		Vario-Tec
	stamping technology		Preci-Point		Contour Jaws
	automation-ready		Makro-4Grip		

WORKHOLDING

1. operation



A Makro-Grip® P

Makro-Grip® Ultra



A Vasto-Clamp

A Makro-4Grip P

2. operation



A Vario-Tec

A Profilo

A Avanti

A Contour Jaws

Makro-Grip® Ultra



A Vasto-Clamp

A Profilo

A Avanti

A Contour Jaws

Preci-Point

Makro-Grip® Ultra



A Profilo

A Avanti

A Contour Jaws

Makro-Grip® Ultra

ZERO POINT CLAMPING SYSTEM



QUICK CLAMPING SYSTEM

AUTOMATION



CHIP FAN





ZERO POINT CLAMPING



- 22 Quick-Point® 52
- 30 Quick-Point® 96
- 42 Quick-Point® 52/96 combi
- 46 Quick-Point® modular plates
- 48 Quick-Point® adapter plates
- 50 Quick-Point® risers
- 54 Quick-Point® tombstones
- 58 Quick-Tower tombstone
- 68 Quick-Point® accessories
- 76 Alignment and mounting options
- 78 Quick-Point® service
- 80 Quick-Point® Rail quick clamping system

Zero point clamping

Zero point clamping systems from LANG Technik are characterized by:

MODULARITY

APPLICATION VARIETY

FASTEST CHANGEOVER TIMES

ZERO POINT PLATES

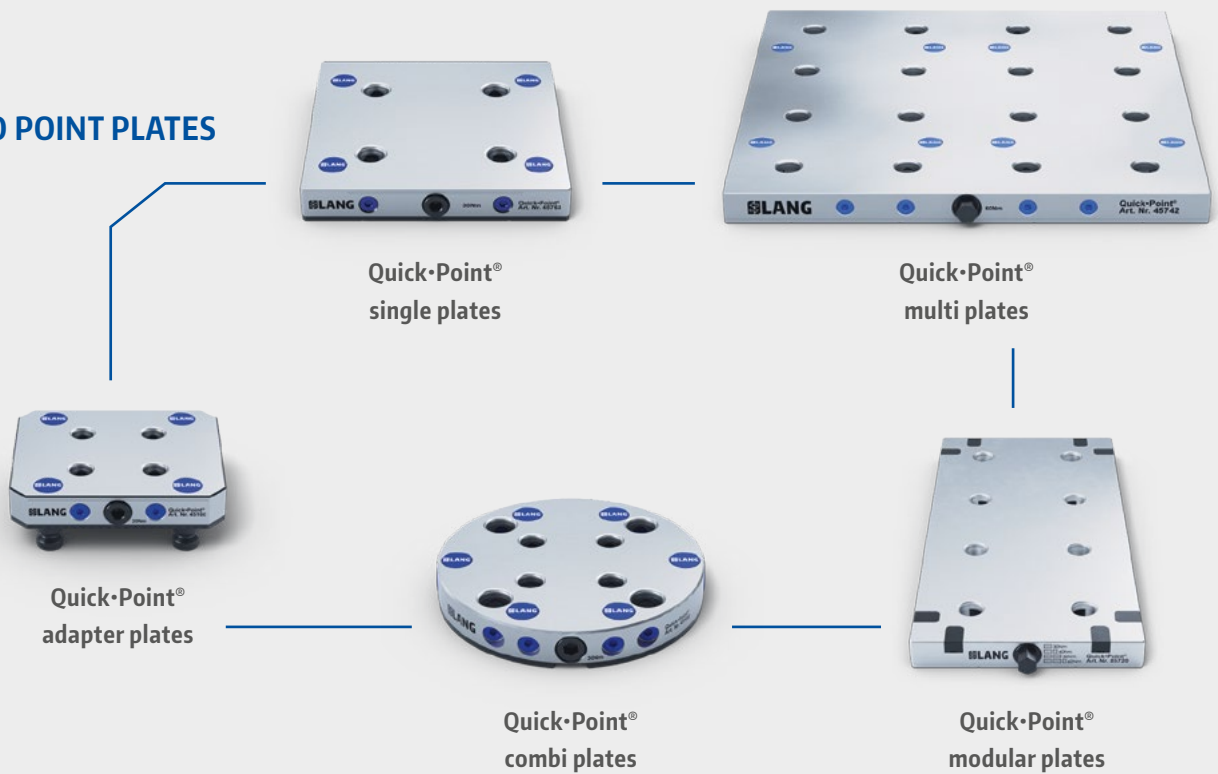

ADD-ON ELEMENTS

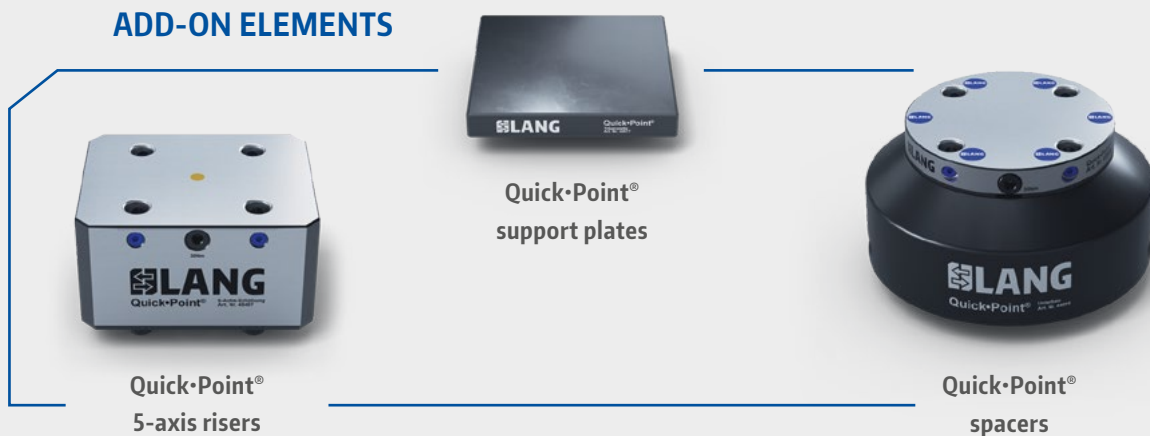

MULTI CLAMPING SYSTEMS AND TOMBSTONES



Quick-Point®
3- / 4-face
tombstone

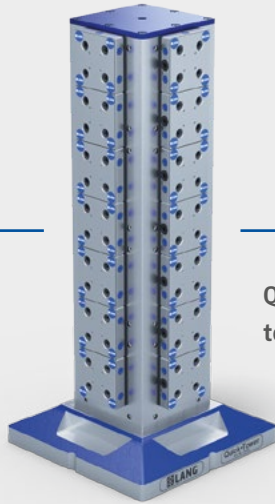

Quick-Tower
tombstone



Quick-Point®
twin base



Quick-Point®
Tri-Top



Quick-Point®
3-face pyramid

QUICK-POINT® RAIL QUICK CLAMPING SYSTEM



Quick-Point® Rail
5-axis combi riser



Quick-Point® Rail
centering vise

AUTOMATION ZERO POINT CLAMPING SYSTEMS



Haubex



RoboTrex Compact



RoboTrex 52



RoboTrex 96

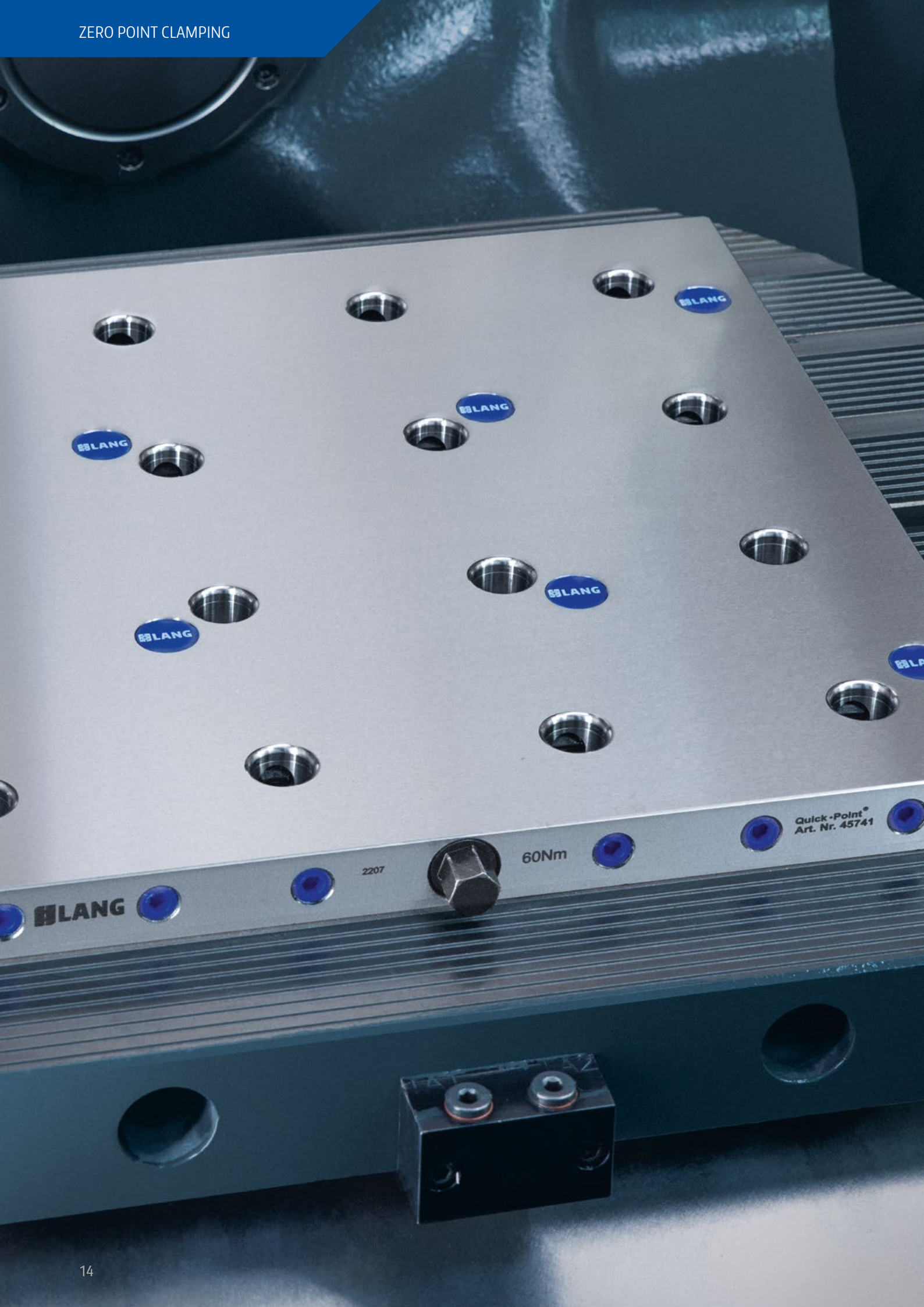

LANG

2207

60Nm

Quick-Point®
Art. Nr. 45741



PATENTED

Quick-Point®

zero point clamping system

The Quick-Point® zero point clamping system is characterized by a particularly wide range of variants and offers a suitable solution for every machine tool. Whether round, rectangular or square in shape, for single or multiple clamping, it can be used universally in vertical and horizontal machining centers, on 3- / 5-axis tables or rotary tables. The simple mechanical operation, solid construction, high precision, and enormous set-up time savings make the Quick-Point® zero point clamping system one of the best on the market.

Primary area of application:

- **Vertical and horizontal milling machines**
- **3-axis / 5-axis tables, automation pallets, rotary tables and clamping bridges**
- **Single and multiple clamping**

Benefits:

- **High application variety and adaptability**
- **Minimum time required for changeovers**
- **Simple, robust and maintenance-free mechanics paired with highest precision**

Quick·Point®

Clamping options:

- direct clamping of workpieces
- LANG Technik vises of all types
- customer-specific devices / fixtures
- vises from other manufacturers

Zero point plate:

- base body made of case-hardened, ground steel
- 27 mm high (one of the lowest systems worldwide)
- zero point grid 52 mm, 96 mm, 52 / 96 mm (combi)
- repeatability < 0.005 mm
- mechanical clamping via hexagon clamping screw
- or alternatively via quick-release fastener
- available with and without predefined mounting holes
- integrated alignment slots and fitting holes

Mounting:

- universally applicable on machine tables, automation pallets, clamping bridges / tombstones or rotary tables
- suitable and prepared with mounting holes for all standard slot tables
- can be customized for any other table / pallet surface





LANG
Quick•Point®
5-Achs-Erhöhung
Art. Nr. 45486

30Nm

LANG

30Nm

Quick•Point®
Art. Nr. 45963

LANG

Functional principle of Quick-Point® zero point plates

By design Quick-Point® is a purely mechanical zero point system. A patented rod system inside the plate guarantees a repeatability of less than 0.005 mm. Quick-Point® plates are actuated by a screw or the Quick-Lock fastening device to ensure simple and easy operation.

With an actuation torque of 30 Nm (60 Nm for 4-fold grid plates) holding forces of up to 6,000 kg are realized. Due to a very small number of wear-free parts the system is reliable and virtually maintenance free.

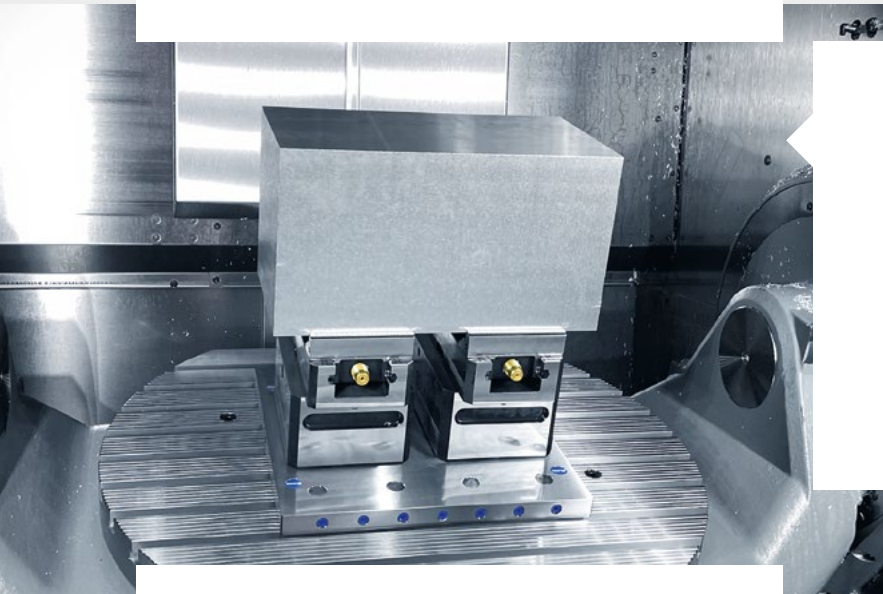

Multi plates

Multi plates offer variable application and positioning options in the zero point clamping system. In particular, larger machine tables can be covered efficiently and over a large area using multi plates. This guarantees maximum flexibility and allows several clamping devices, fixtures or workpieces to be used on a machine table at the same time.

Adapter plates

The use of adapter plates makes it possible to change the system size of Quick-Point®. It takes no time at all to convert from the 96 mm to the 52 mm zero point grid. The modular design of the system allows both large and small LANG vises and clamping devices to be used on the same machine table without having to fundamentally change the set-up. The use of an adapter plate raises the position of the clamping device, which above all improves accessibility when milling small workpieces.



Combi plates

Combi plates combine the two grid dimensions 52 and 96 mm in one zero point plate and guarantee the ultimate freedom in the choice of clamping devices. The combined zero point grid allows all LANG vises to be used in a single plate, which saves time, especially during changeovers. Combi plates are available in square, rectangular and round versions, as well as 5-axis combi risers and twin base versions.

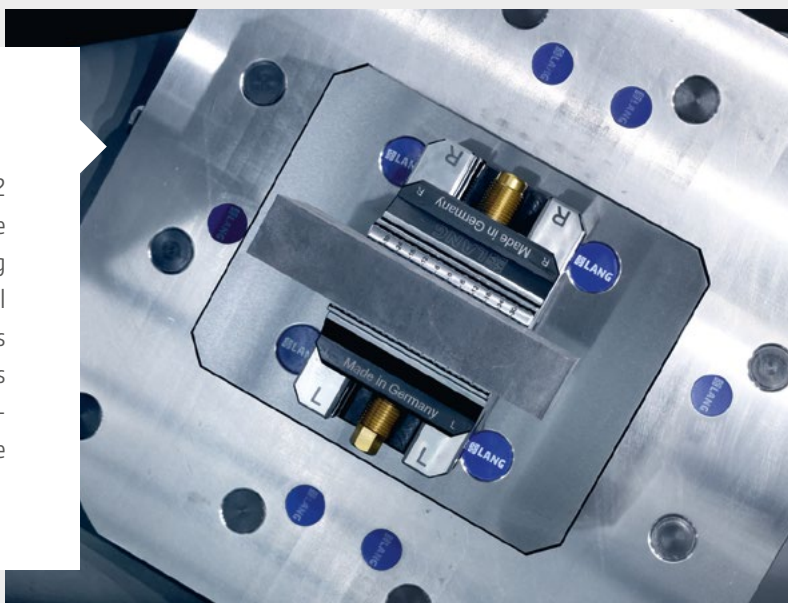

Modular plates

Modular plates allow several connected plates to be clamped simultaneously with just one clamping screw. Up to two 2-fold modular plates and a single modular plate can be connected to each other. Modular plates provide an excellent foundation for setting up workholding systems that are clamped across several zero point units.

Automation zero point clamping system

The Quick·Point® zero point clamping system is used not only in conventional manual machining, but also in automated unmanned production. The zero point clamping system can be opened and closed either by the machine tool or by the robot gripper. This is done either by the robot mechanically operating the lever or via the gripper's pneumatic interface. This means that a media interface inside the machine is not necessary.

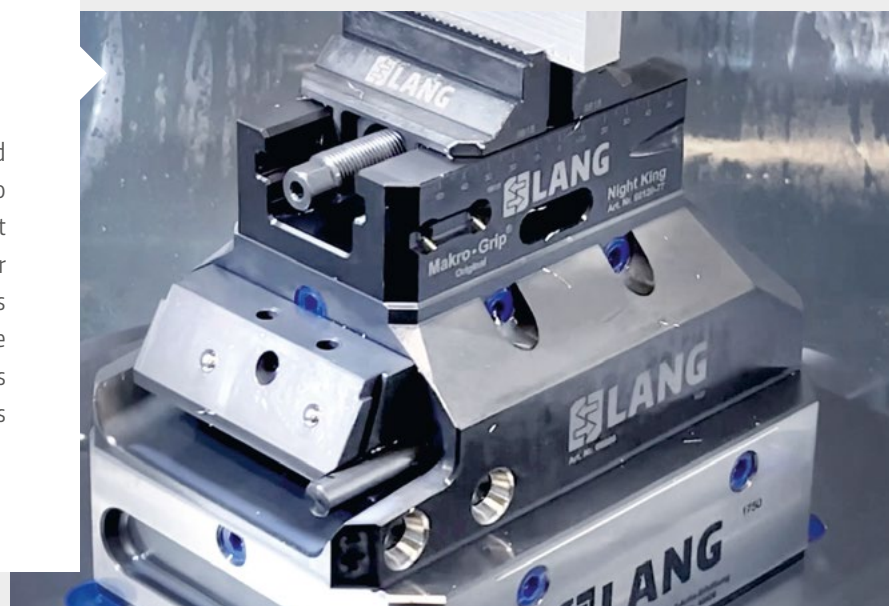



Poseidon Propulsion B.V.

Direct clamping of workpieces and fixtures

Quick-Point® clamping studs connect the zero point system and LANG workholding devices. They can be also mounted directly to a workpiece in order to clamp it directly without a workholding device. Even the mounting to customers' own fixtures or conventional vises is possible in order to benefit from all the advantages of the Quick-Point® zero point clamping system. The connection between clamping studs and zero point plate is extremely robust, very precise and can undoubtedly resist even the strongest machining forces.



High degree of customization possibilities

All of our Quick-Point® plates with prefabricated mounting bores are also available without such, in order to be individually adapted to any kind of machine table. If the zero point plate protrudes the machine table, cutting off the plate's corners provides a nice and clean customization.

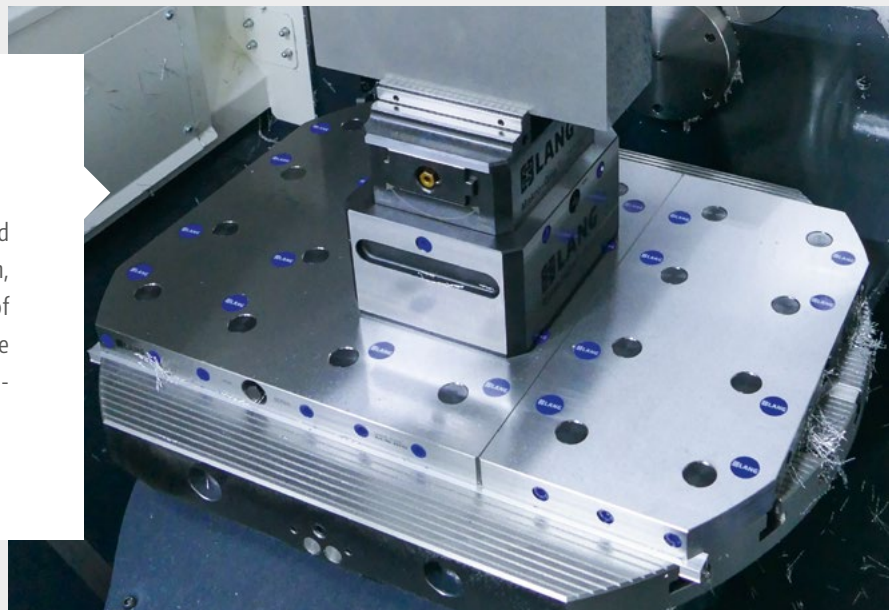

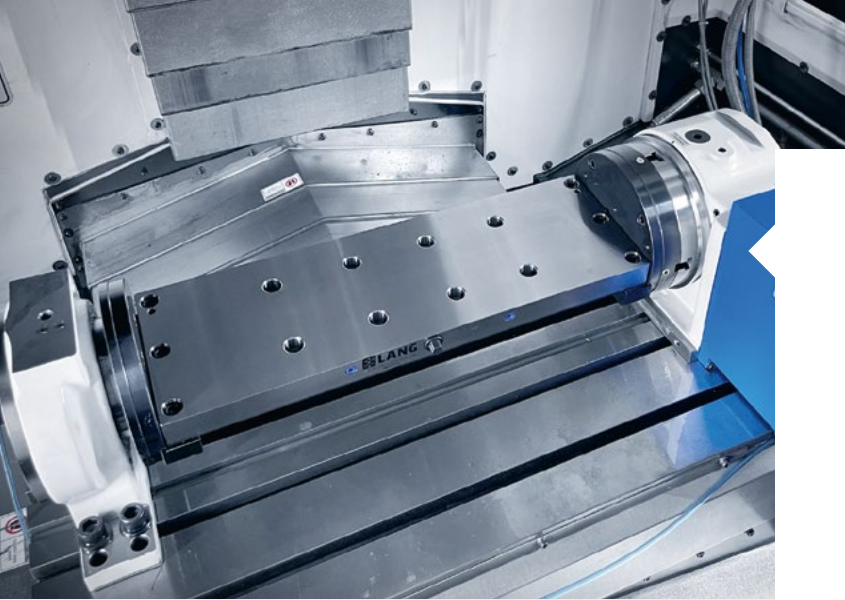

A great fit for rotary tables

The low overall height, the wide range of customization options and the mechanical functional principle make the Quick-Point® zero point clamping system a great choice for rotary tables, e.g. from Kitagawa, Lehmann, Nikken or Haas, just to name a few. Rotary tables and trunnions can be retrofitted easily with Quick-Point® plates which provide added value in terms of flexibility and set-up time savings.

Increased productivity with multiple clamping systems and tombstones

The Quick-Point® zero point clamping system also offers numerous options for multiple clamping, whether in larger horizontal machining centers or smaller 3- or 5-axis machines, to automatically extend machine runtimes while at the same time reducing tool changes.

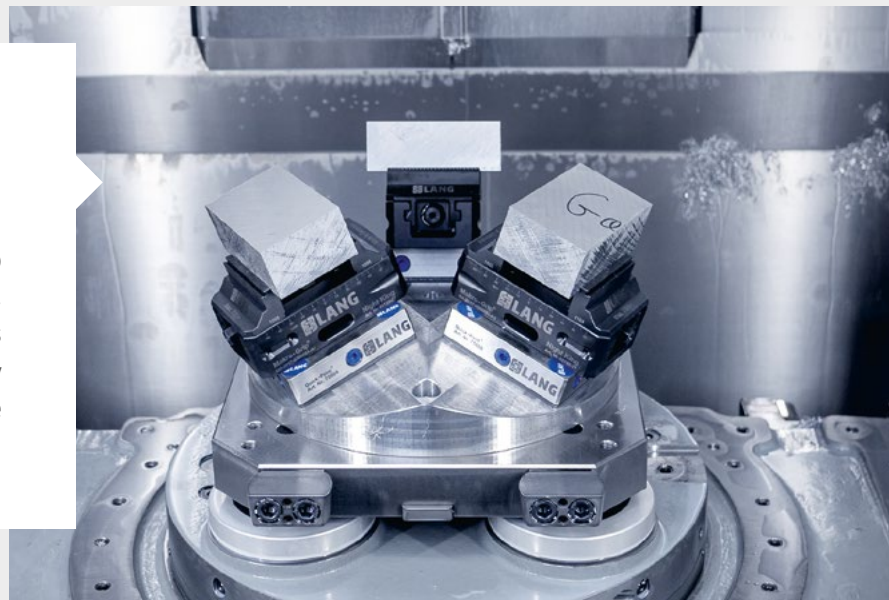

Quick-Point® 52 single plates

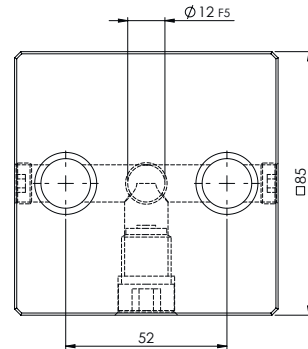

NEW

QUICK-POINT® 52 DUO2, GRID PLATE 85 × 85 × 27 MM, WITHOUT MOUNTING BORES

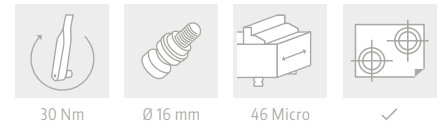

ITEM NO.	DIMENSIONS	WEIGHT
45602	85 × 85 × 27 mm	1.4 kg
45004	Set mounting bores according to customer's request	
45002	Set keyways according to customer's request	

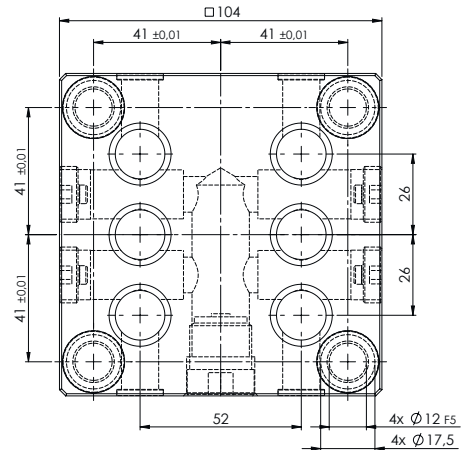

NEW

QUICK-POINT® 52 DUO6, GRID PLATE 104 × 104 × 27 MM, WITH MOUNTING BORES FOR QUICK-TOWER

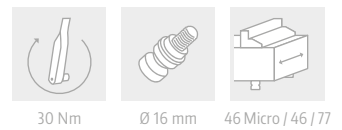

ITEM NO.	DIMENSIONS	MOUNTING BORES	WEIGHT
75606	104 × 104 × 27 mm	82 × 82 mm	1.8 kg

Includes: 4 × M 10 × 35 screws, 2 pcs. Ø 12 × 12 mm bushings (Item No. 45000-09).
This product is also shown on page 66.

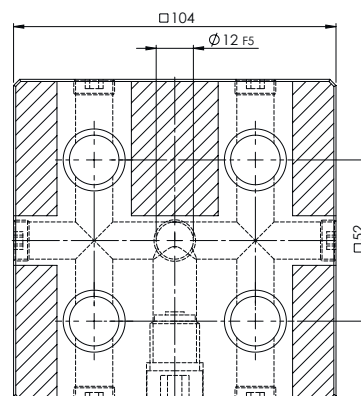

QUICK-POINT® 52, GRID PLATE
104 × 104 × 27 MM, WITHOUT MOUNTING BORES

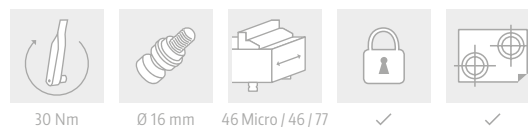

ITEM NO.	DIMENSIONS	WEIGHT
45600	104 × 104 × 27 mm	2.0 kg
45004	Set mounting bores according to customer's request	
45002	Set keyways according to customer's request	

Suitable Quick-Lock: Item No. 44552 (page 72).

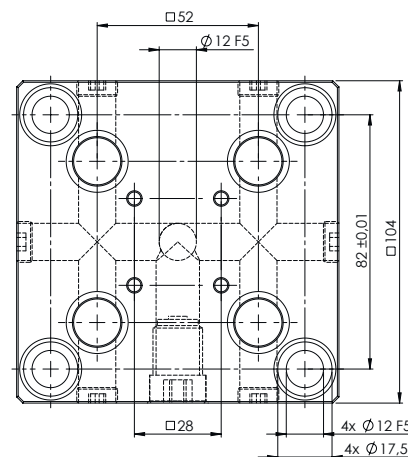

QUICK-POINT® 52, GRID PLATE
104 × 104 × 27 MM, WITH MOUNTING BORES FOR QUICK-TOWER

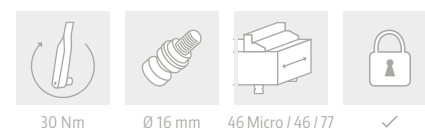

ITEM NO.	DIMENSIONS	MOUNTING BORES	WEIGHT
75600	104 × 104 × 27 mm	82 × 82 mm	1.8 kg

Suitable Quick-Lock: Item No. 44552 (page 72).

Includes: 4 × M 10 × 35 screws, 2 pcs. Ø 12 × 12 mm bushings (Item No. 45000-09).

This product is also shown on page 66.

Quick-Point® 52 single plates

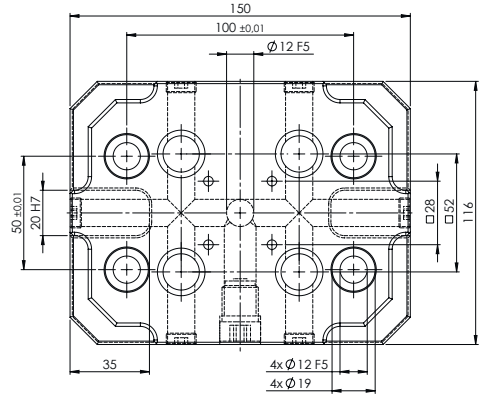

QUICK-POINT® 52, PLATE WITH CLAMPING EDGE 150 × 116 × 27 MM

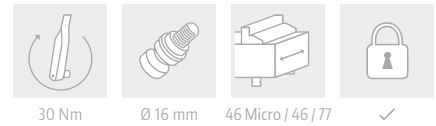

ITEM NO.	DIMENSIONS	MOUNTING BORES	WEIGHT
45150	150 × 116 × 27 mm	100 × 50 mm	2.8 kg

Suitable Quick-Lock: Item No. 44552 (page 72).

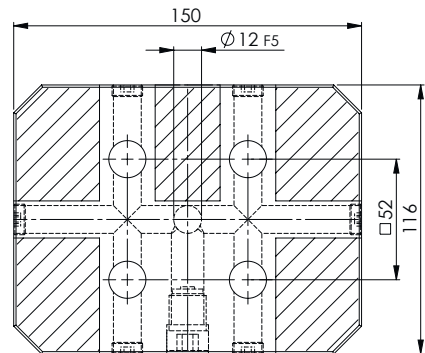

QUICK-POINT® 52, PLATE WITHOUT CLAMPING EDGE 150 × 116 × 27 MM, WITHOUT MOUNTING BORES



ITEM NO.	DIMENSIONS	WEIGHT
45151	150 × 116 × 27 mm	3.3 kg
45004	Set mounting bores according to customer's request	
45002	Set keyways according to customer's request	

Suitable Quick-Lock: Item No. 44552 (page 72).

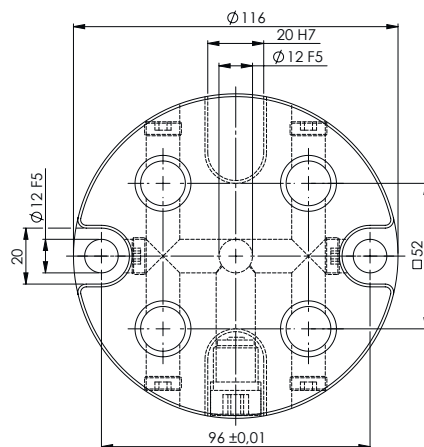

QUICK-POINT® 52, ROUND PLATE
Ø 116 × 27 MM

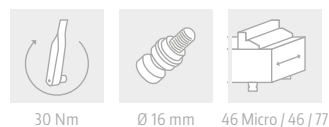

ITEM NO.	DIMENSIONS	MOUNTING BORES	WEIGHT
45750	Ø 116 × 27 mm	96 mm spacing	1.8 kg

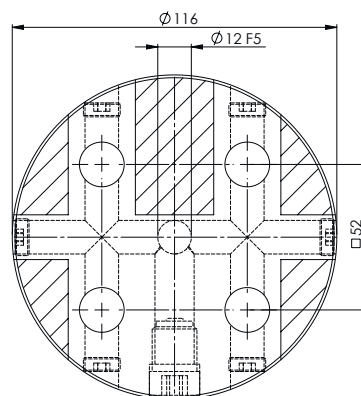

QUICK-POINT® 52, ROUND PLATE
Ø 116 × 27 MM, WITHOUT MOUNTING BORES

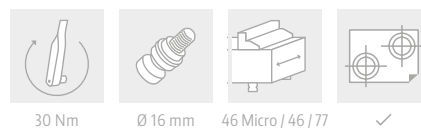

ITEM NO.	DIMENSIONS	WEIGHT
45751	Ø 116 × 27 mm	1.9 kg
45004	Set mounting bores according to customer's request	
45002	Set keyways according to customer's request	

Quick-Point® 52 single plates

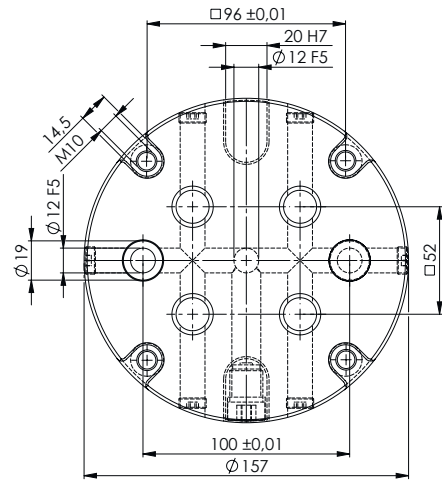

QUICK-POINT® 52, ROUND PLATE Ø 157 × 27 MM

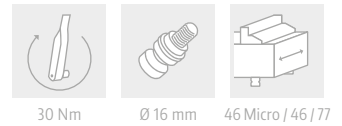

ITEM NO.	DIMENSIONS	MOUNTING BORES	WEIGHT
45900	Ø 157 × 27 mm	100 mm spacing	3.4 kg

Note: This round plate can be converted into an adapter plate by inserting 4 × Quick-Point® clamping studs Ø 20 mm, Item No. 45570, into the M10 threads.

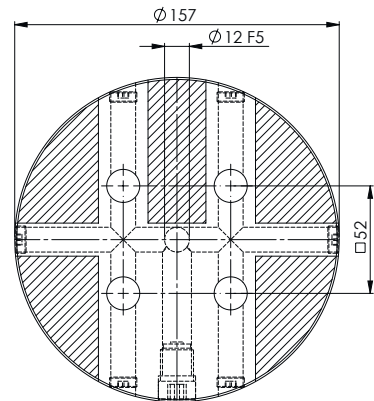

QUICK-POINT® 52, ROUND PLATE Ø 157 × 27 MM, WITHOUT MOUNTING BORES

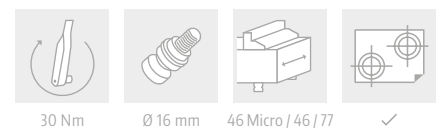

ITEM NO.	DIMENSIONS	WEIGHT
45901	Ø 157 × 27 mm	3.7 kg
45004	Set mounting bores according to customer's request	
45002	Set keyways according to customer's request	

Quick·Point® 52 single plate for individual center bore

A center bore with individually selectable diameter and tolerance provides the option for access to rotary joints.

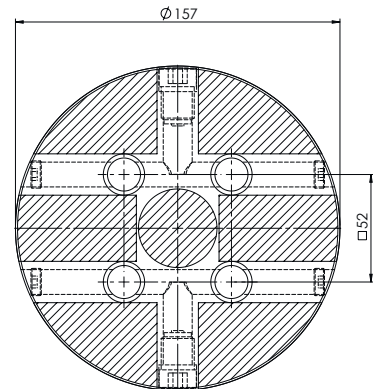

QUICK·POINT® 52, ROUND PLATE Ø 157 × 27 MM, FOR INDIVIDUAL CENTER BORE

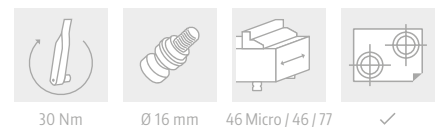

ITEM NO.	DIMENSIONS	MAX. Ø CENTER BORE	WEIGHT
45903	Ø 157 × 27 mm	38 mm	3.7 kg
45004		Set mounting bores according to customer's request	
45002		Set keyways according to customer's request	
45009		Set center bore according to customer's request	

Possible modification:



- 1 × center bore Ø 38 mm
- 1 × keyway 20H7
- 4 × mounting bores for M8 screws, incl. step for Ø 15 mm cover discs, for machine tables with 6 × 60° grooves

Quick-Point® 52 multi plates

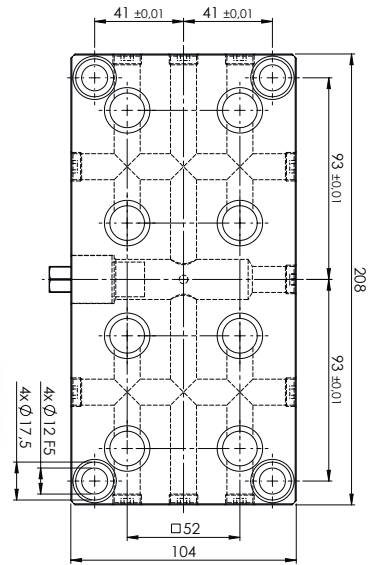

QUICK-POINT® 52, 2-FOLD GRID PLATE 208 × 104 × 27 MM

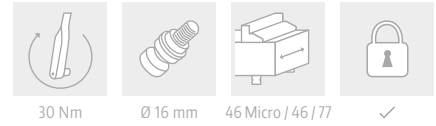

ITEM NO.	DIMENSIONS	MOUNTING BORES	WEIGHT
45621	208 × 104 × 27 mm	186 × 82 mm	3.8 kg

Suitable Quick-Lock: Item No. 45252 (page 72).

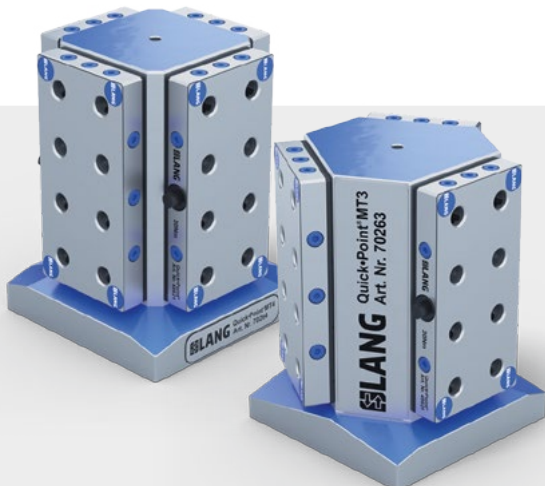

Note:

Suitable for our tombstones!

With its mounting holes, the 2-fold grid plate can be attached to the 3- and 4-face tombstones, as well as to the Quick-Tower.

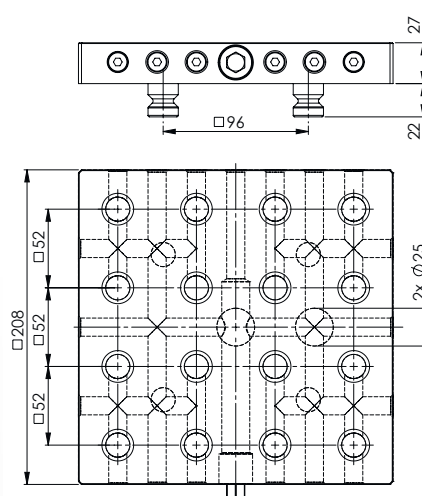

QUICK-POINT® 52, 4-FOLD GRID PLATE
208 × 208 × 27 MM, WITHOUT MOUNTING BORES

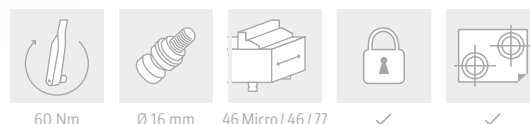

ITEM NO.	DIMENSIONS	WEIGHT
45640	208 × 208 × 27 mm	8.3 kg
45644	Set mounting bores according to customer's request	
45642	Set keyways according to customer's request	

Includes: 4 Quick-Point® 96 clamping studs Ø 20 mm (Item No. 45570).
 Suitable Quick-Lock: Item No. 45452 (page 72).

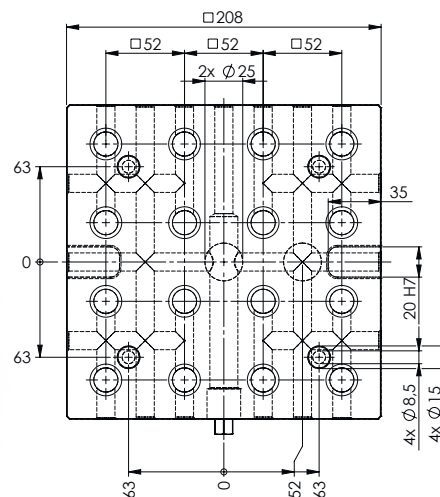

QUICK-POINT® 52, 4-FOLD PLATE
208 × 208 × 27 MM, WITH MOUNTING BORES FOR 63 MM T-SLOT TABLES

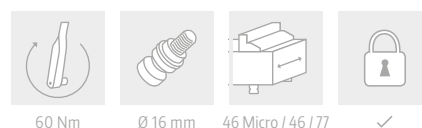

ITEM NO.	DIMENSIONS	MOUNTING BORES	WEIGHT
45641	208 × 208 × 27 mm	for 63 mm t-slot distance	8.0 kg

Suitable Quick-Lock: Item No. 45452 (page 72).

Quick-Point® 96 single plates

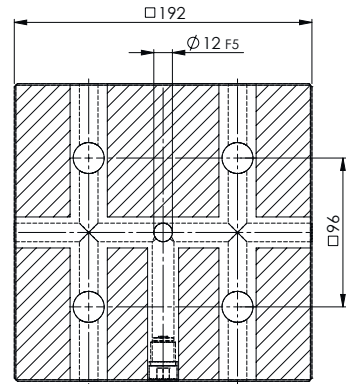

QUICK-POINT® 96, GRID PLATE 192 × 192 × 27 MM, WITHOUT MOUNTING BORES

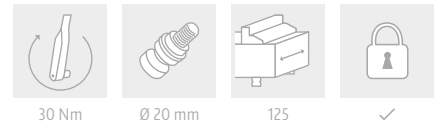

ITEM NO.	DIMENSIONS	WEIGHT
45710	192 × 192 × 27 mm	7.3 kg
45004	Set mounting bores according to customer's request	
45002	Set keyways according to customer's request	

Suitable Quick-Lock: Item No. 44596 (page 72).

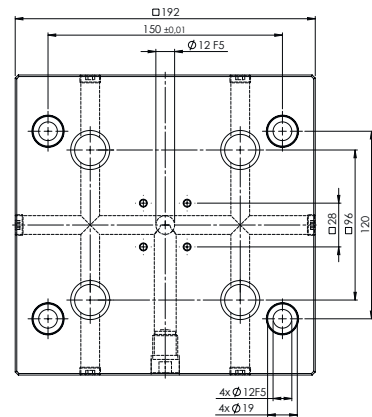

QUICK-POINT® 96, GRID PLATE 192 × 192 × 27 MM, WITH MOUNTING BORES FOR QUICK-TOWER

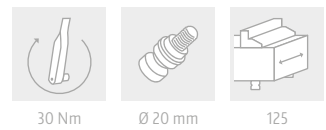

ITEM NO.	DIMENSIONS	MOUNTING BORES	WEIGHT
75710	192 × 192 × 27 mm	150 × 120 mm	7.2 kg

Suitable Quick-Lock: Item No. 44596 (page 72).
This product is also shown on page 67.

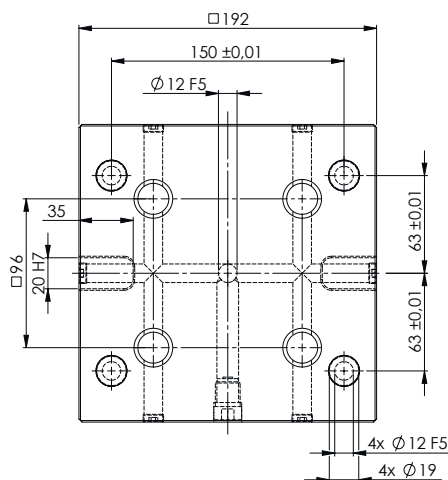

QUICK-POINT® 96, GRID PLATE
192 × 192 × 27 MM, WITH MOUNTING BORES FOR 63 MM T-SLOT TABLES

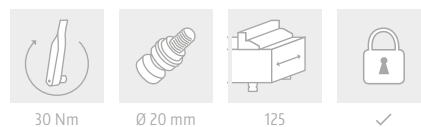

ITEM NO.	DIMENSIONS	MOUNTING BORES	WEIGHT
45763	192 × 192 × 27 mm	for 63 mm t-slot distance	7.1 kg

Suitable Quick-Lock: Item No. 44596 (page 72).



Note:

Also available as combi plates!

The square grid plate also comes in two different combi plate versions with 52 / 96 mm zero point grid. Both types are shown on page 42.

Quick-Point® 96 single plate

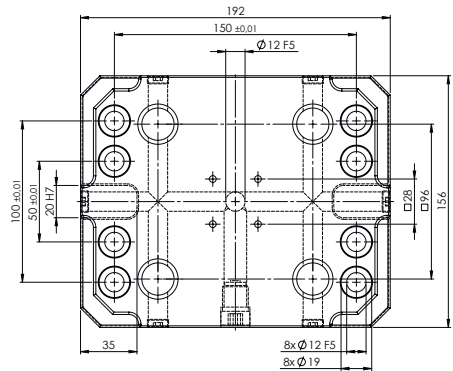

QUICK-POINT® 96, PLATE WITH CLAMPING EDGE 192 × 156 × 27 MM

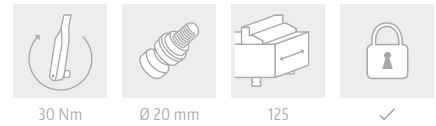

ITEM NO.	DIMENSIONS	MOUNTING BORES	WEIGHT
45400	192 × 156 × 27 mm	150 × 100 / 50 mm	5.2 kg

Suitable Quick-Lock: Item No. 44596 (page 72).

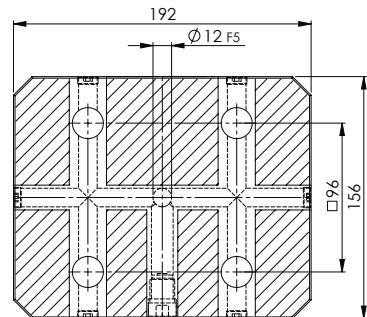

QUICK-POINT® 96, PLATE WITHOUT CLAMPING EDGE 192 × 156 × 27 MM, WITHOUT MOUNTING BORES

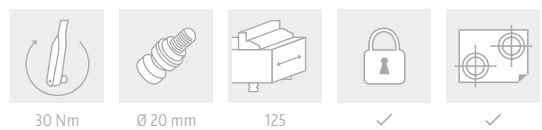

ITEM NO.	DIMENSIONS	WEIGHT
45401	192 × 156 × 27 mm	5.9 kg
45004	Set mounting bores according to customer's request	
45002	Set keyways according to customer's request	

Suitable Quick-Lock: Item No. 44596 (page 72).

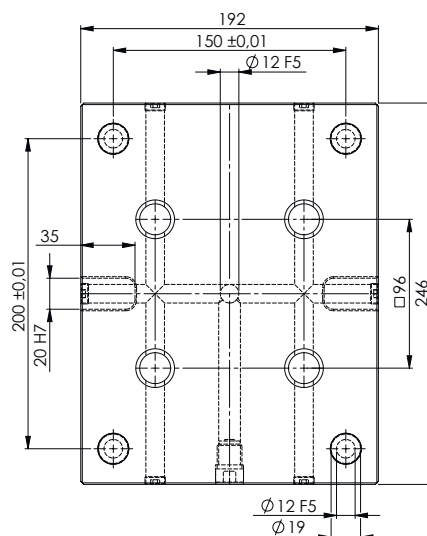

QUICK-POINT® 96, EXTENDED GRID PLATE
246 × 192 × 27 MM, WITH MOUNTING BORES FOR 100 MM T-SLOT TABLES

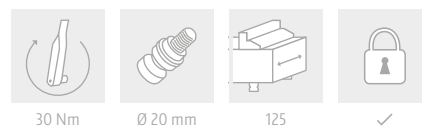

ITEM NO.	DIMENSIONS	MOUNTING BORES	WEIGHT
45715	246 × 192 × 27 mm	for 100 mm t-slot distance	9.2 kg

Suitable Quick-Lock: Item No. 44596 (page 72).

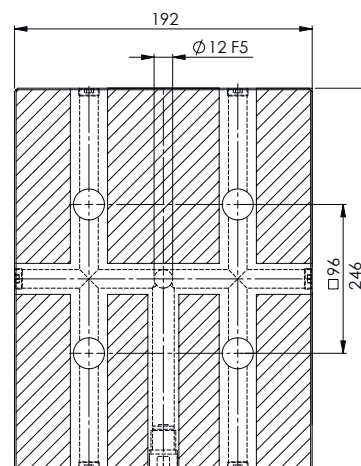

QUICK-POINT® 96, EXTENDED GRID PLATE
246 × 192 × 27 MM, WITHOUT MOUNTING BORES

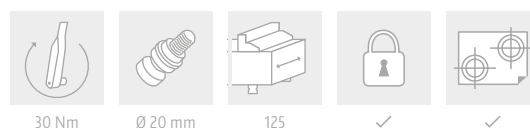

ITEM NO.	DIMENSIONS	WEIGHT
45716	246 × 192 × 27 mm	9.4 kg
45004	Set mounting bores according to customer's request	
45002	Set keyways according to customer's request	

Suitable Quick-Lock: Item No. 44596 (page 72).

Quick-Point® 96 single plates

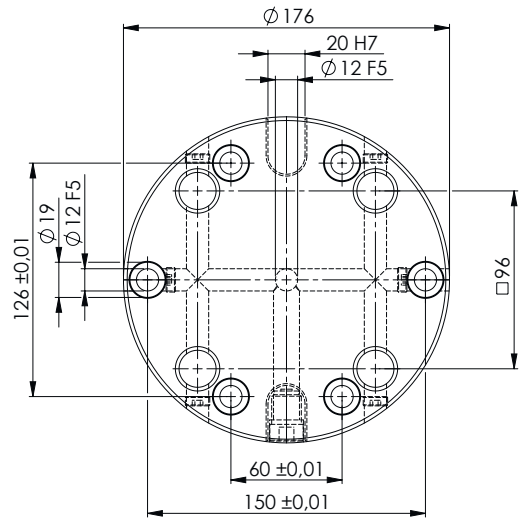

QUICK-POINT® 96, ROUND PLATE Ø 176 × 27 MM

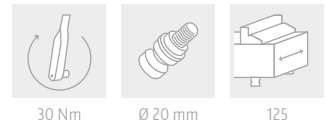

ITEM NO.	DIMENSIONS	MOUNTING BORES	WEIGHT
45800	Ø 176 × 27 mm	for 63 mm t-slot distance and 150 mm spacing	4.5 kg

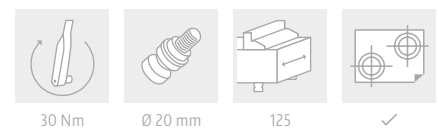
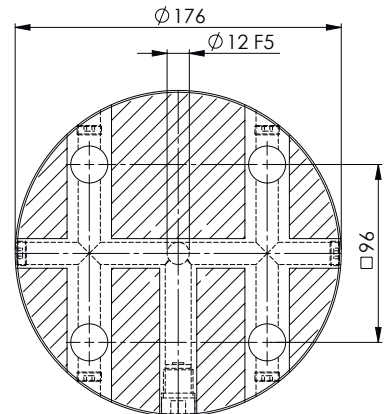

QUICK-POINT® 96, ROUND PLATE Ø 176 × 27 MM, WITHOUT MOUNTING BORES

ITEM NO.	DIMENSIONS	WEIGHT
45801	Ø 176 × 27 mm	4.8 kg
45004	Set mounting bores according to customer's request	
45002	Set keyways according to customer's request	

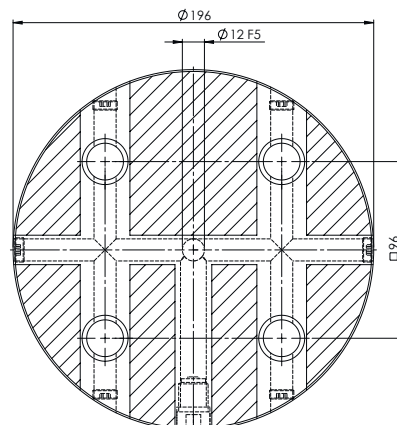

QUICK-POINT® 96, ROUND PLATE
Ø 196 × 27 MM, WITHOUT MOUNTING BORES

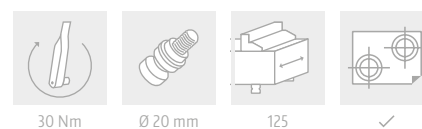

ITEM NO.	DIMENSIONS	WEIGHT
45820	Ø 196 × 27 mm	5.9 kg
45004	Set mounting bores according to customer's request	
45002	Set keyways according to customer's request	

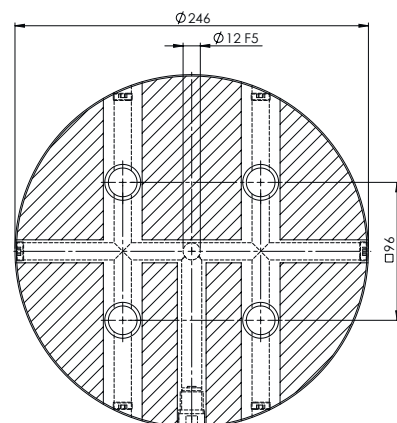
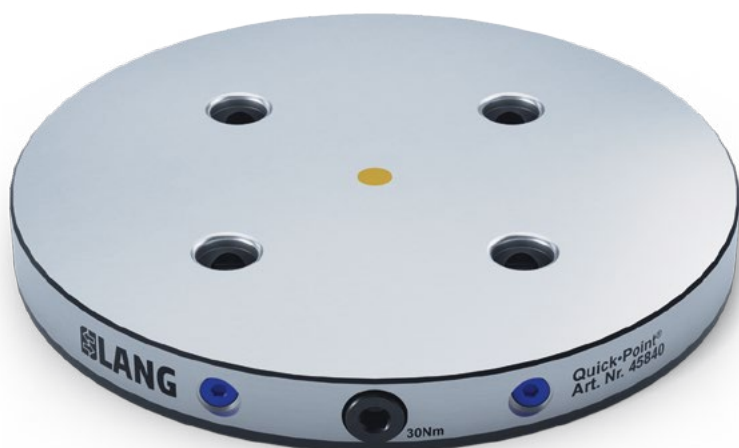

QUICK-POINT® 96, ROUND PLATE
Ø 246 × 27 MM, WITHOUT MOUNTING BORES

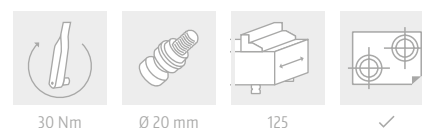

ITEM NO.	DIMENSIONS	WEIGHT
45840	Ø 246 × 27 mm	9.5 kg
45004	Set mounting bores according to customer's request	
45002	Set keyways according to customer's request	

Quick-Point® 96 single plates

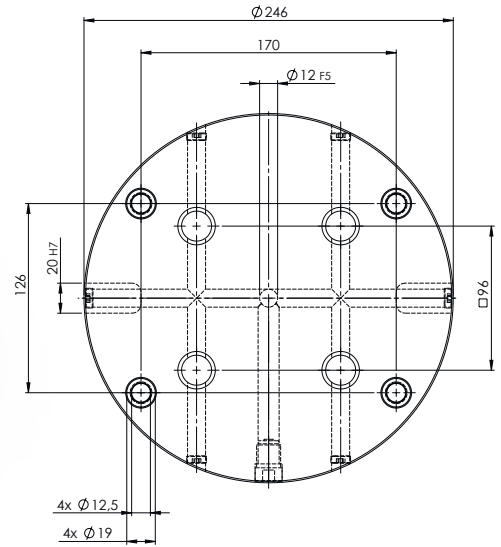
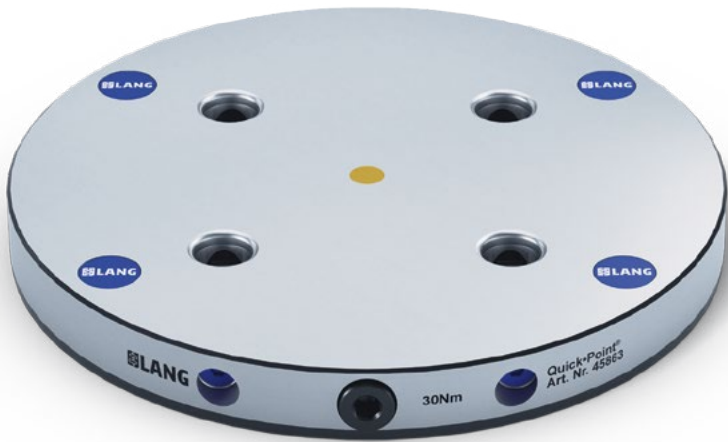

QUICK-POINT® 96, ROUND PLATE
Ø 246 × 27 MM, WITH MOUNTING BORES FOR 63 MM T-SLOT TABLES

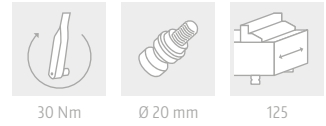

ITEM NO.	DIMENSIONS	MOUNTING BORES	WEIGHT
45863	Ø 246 × 27 mm	for 63 mm t-slot distance	9.2 kg

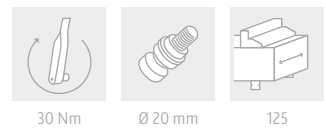
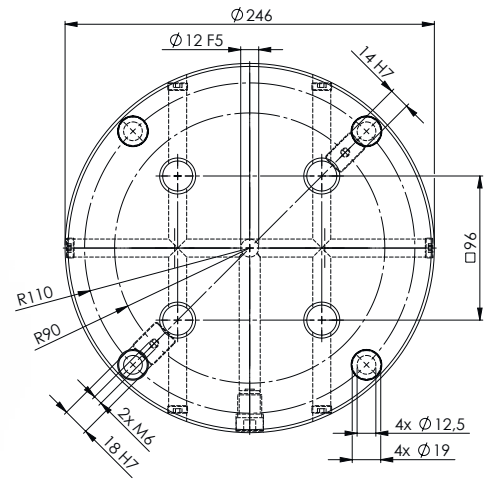

QUICK-POINT® 96, ROUND PLATE
Ø 246 × 27 MM, WITH MOUNTING BORES FOR TABLES WITH 90° GROOVES

ITEM NO.	DIMENSIONS	MOUNTING BORES	WEIGHT
45890	Ø 246 × 27 mm	4 × 90° / Radius 110 mm	9.2 kg

Suitable slot keys: Item No. 452214 / 452218 (page 75).

Quick·Point® 96 single plates for individual center bore

A center bore with individually selectable diameter and tolerance provides the option for access to rotary joints.

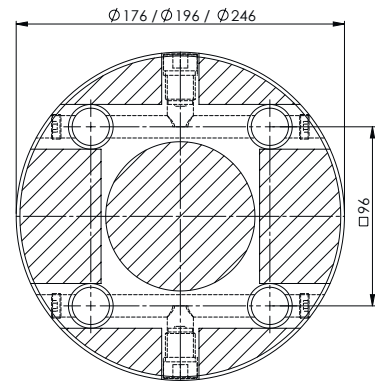

QUICK-POINT® 96, ROUND PLATES Ø 176 / 196 / 246 × 27 MM, FOR INDIVIDUAL CENTER BORE

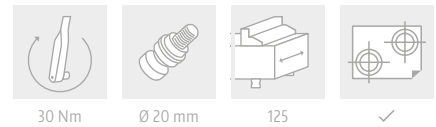

ITEM NO.	DIMENSIONS	MAX. Ø CENTER BORE	WEIGHT
45803	Ø 176 × 27 mm	80 mm	4.8 kg
45823	Ø 196 × 27 mm	80 mm	6.0 kg
45843	Ø 246 × 27 mm	80 mm	9.6 kg
45004	Set mounting bores according to customer's request		
45002	Set keyways according to customer's request		
45009	Set center bore according to customer's request		

Possible modification:





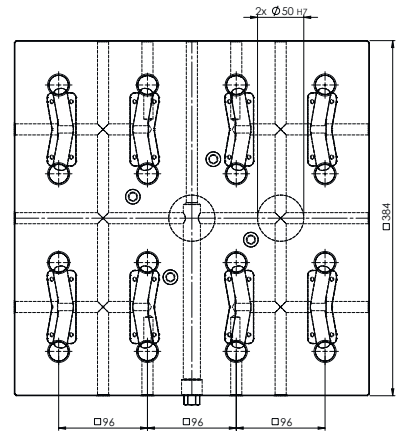

- 1 × center bore Ø 80 mm
- 1 × 130 H6 tapered fitting
- 4 × mounting bores for M12 screws, incl. step for Ø 20 mm cover discs, for machine tables with 6 × 60° grooves

Quick-Point® 96 multi plates

EVEN STRONGER, THANKS TO NEW MECHANICS 



QUICK-POINT® 96, 4-FOLD GRID PLATE
384 × 384 × 27 MM, WITHOUT MOUNTING BORES

-  60 Nm
-  Ø 20 mm
-  125
- 

ITEM NO.	DIMENSIONS	WEIGHT
45740	384 × 384 × 27 mm	29.4 kg
45044	Set mounting bores according to customer's request	
45042	Set keyways according to customer's request	

Applications

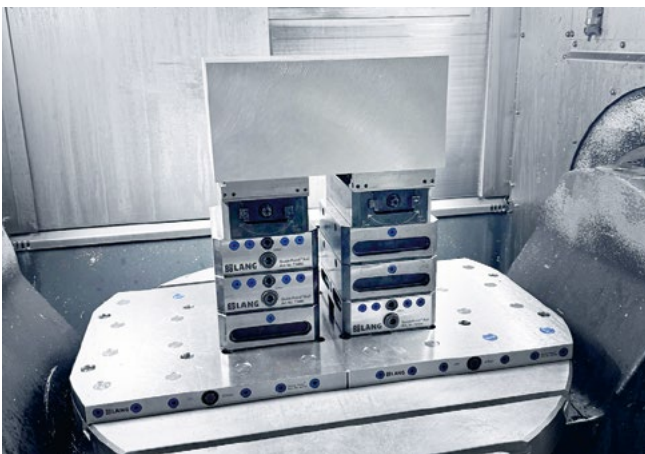

T. Zimmer Maschinenbau & CNC-Technik

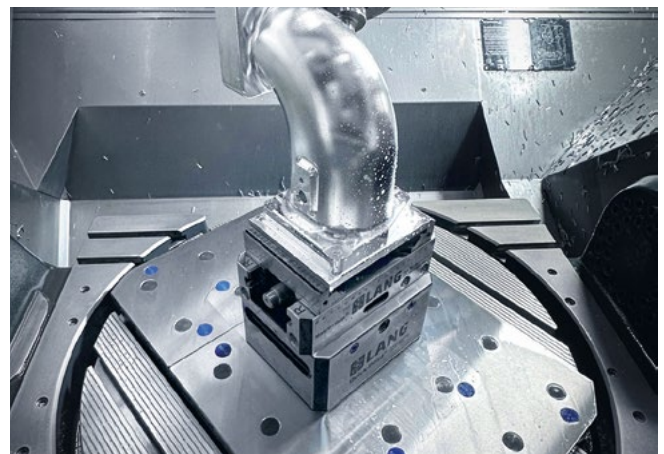

Nueva Precision

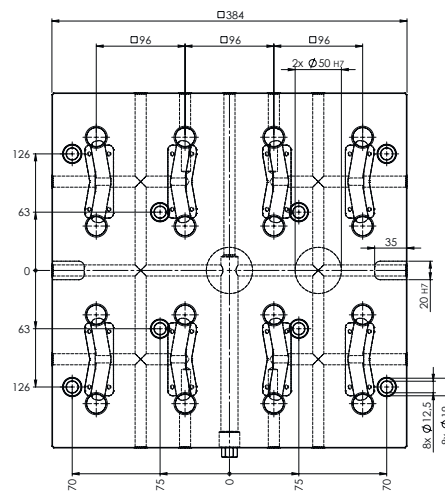

QUICK-POINT® 96, 4-FOLD GRID PLATE
384 × 384 × 27 MM, WITH MOUNTING BORES FOR 63 MM T-SLOT TABLES

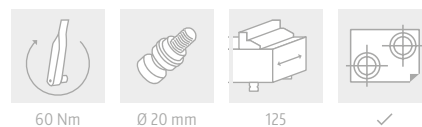

ITEM NO.	DIMENSIONS	MOUNTING BORES	WEIGHT
45741	384 × 384 × 27 mm	for 63 mm t-slot distance	28.9 kg

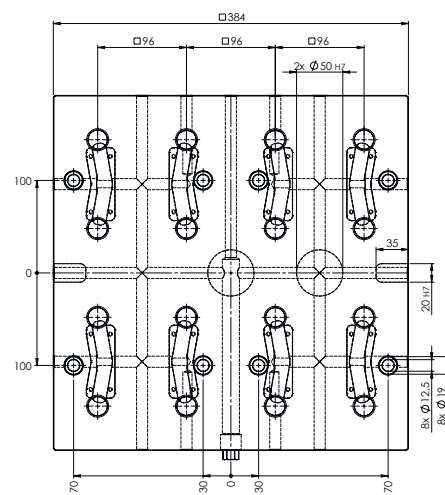

QUICK-POINT® 96, 4-FOLD GRID PLATE
384 × 384 × 27 MM, WITH MOUNTING BORES FOR 100 MM T-SLOT TABLES

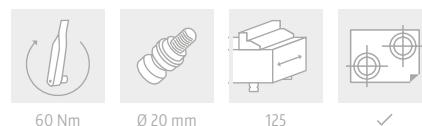

ITEM NO.	DIMENSIONS	MOUNTING BORES	WEIGHT
45742	384 × 384 × 27 mm	for 100 mm t-slot distance	28.9 kg

Quick-Point® 96 multi plates

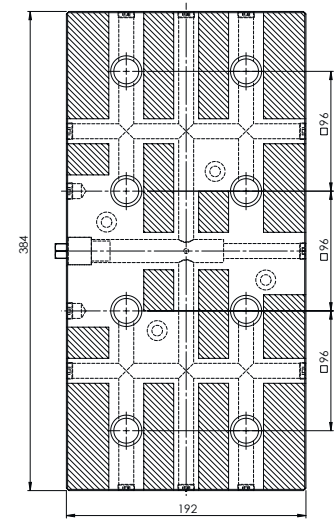

QUICK-POINT® 96, 2-FOLD GRID PLATE 384 × 192 × 27 MM, WITHOUT MOUNTING BORES



ITEM NO.	DIMENSIONS	WEIGHT
45720	384 × 192 × 27 mm	14.6 kg
45024	Set mounting bores according to customer's request	
45022	Set keyways according to customer's request	

Suitable Quick-Lock: Item No. 45296 (page 72).

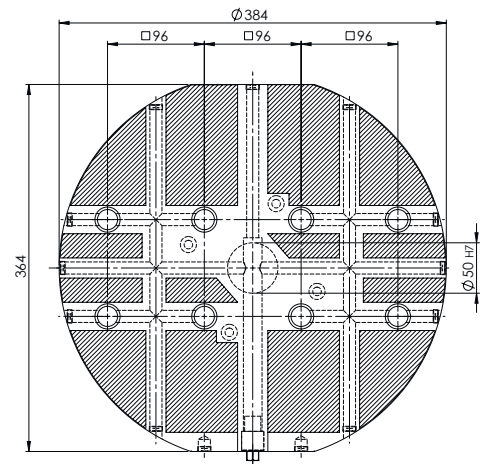

QUICK-POINT® 96, 2-FOLD GRID PLATE, ROUND Ø 384 × 27 MM, WITHOUT MOUNTING BORES

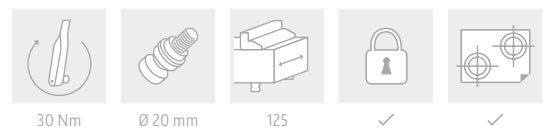

ITEM NO.	DIMENSIONS	WEIGHT
45962	Ø 384 × 27 mm	22.8 kg
45044	Set mounting bores according to customer's request	
45042	Set keyways according to customer's request	

Suitable Quick-Lock: Item No. 45996 (page 72).

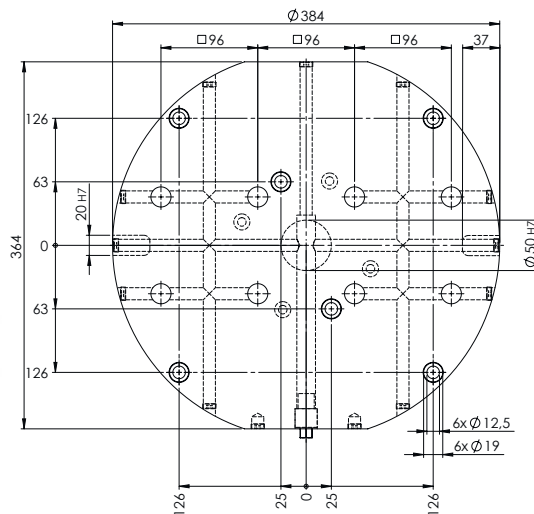

**QUICK-POINT® 96, 2-FOLD GRID PLATE, ROUND
Ø 384 × 27 MM, WITH MOUNTING BORES FOR 63 MM T-SLOT TABLES**

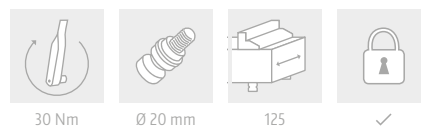

ITEM NO.	DIMENSIONS	MOUNTING BORES	WEIGHT
45963	Ø 384 × 27 mm	for 63 mm t-slot distance	22.6 kg

Suitable Quick-Lock: Item No. 45996 (page 72).

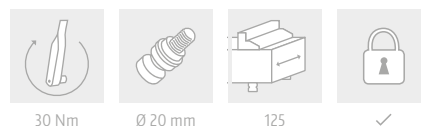
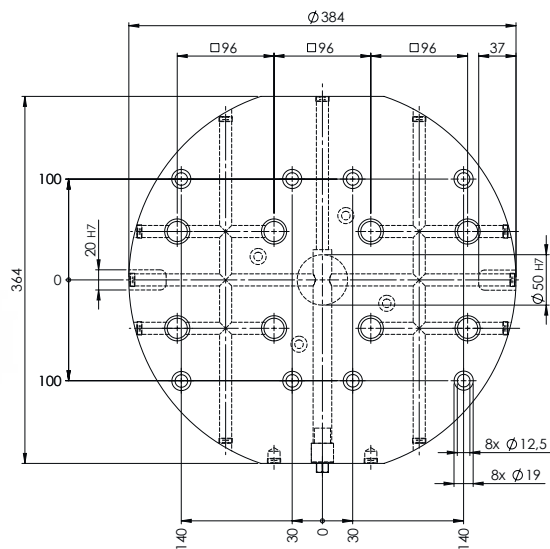

**QUICK-POINT® 96, 2-FOLD GRID PLATE, ROUND
Ø 384 × 27 MM, WITH MOUNTING BORES FOR 100 MM T-SLOT TABLES**

ITEM NO.	DIMENSIONS	MOUNTING BORES	WEIGHT
45964	Ø 384 × 27 mm	for 100 mm t-slot distance	22.4 kg

Suitable Quick-Lock: Item No. 45996 (page 72).

Quick-Point® 52 / 96 combi plates

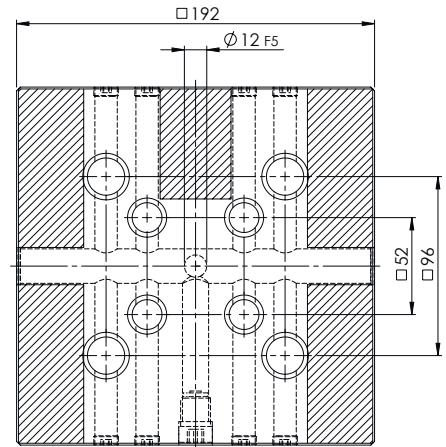

QUICK-POINT® 52 / 96, COMBI GRID PLATE 192 × 192 × 27 MM, WITHOUT MOUNTING BORES



ITEM NO.	DIMENSIONS	WEIGHT
45748	192 × 192 × 27 mm	6.8 kg
45004	Set mounting bores according to customer's request	
45002	Set keyways according to customer's request	

Suitable Quick-Lock: Item No. 44552 or 44596 (page 72).

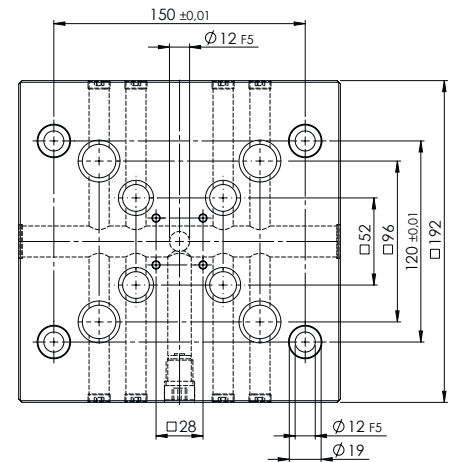

QUICK-POINT® 52 / 96, COMBI GRID PLATE 192 × 192 × 27 MM, WITH MOUNTING BORES FOR QUICK-TOWER

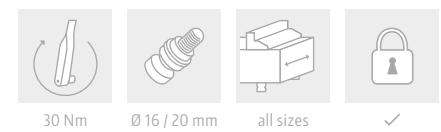

ITEM NO.	DIMENSIONS	MOUNTING BORES	WEIGHT
75748	192 × 192 × 27 mm	150 × 120 mm	6.6 kg

Suitable Quick-Lock: Item No. 44552 or 44596 (page 72).

This product is also shown on page 67.

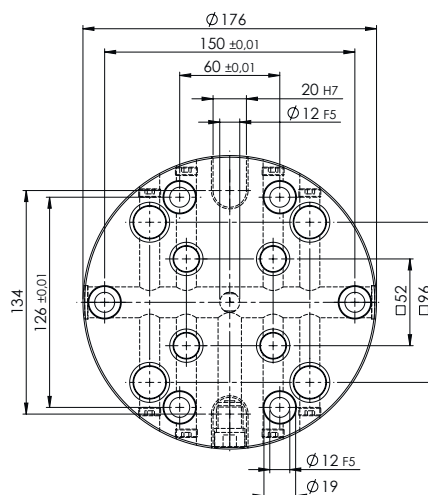

**QUICK-POINT® 52 / 96, COMBI ROUND PLATE
Ø 176 × 27 MM**

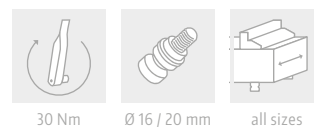

ITEM NO.	DIMENSIONS	MOUNTING BORES	WEIGHT
45480	Ø 176 × 27 mm	for 63 mm t-slot distance and 150 mm spacing	4.1 kg

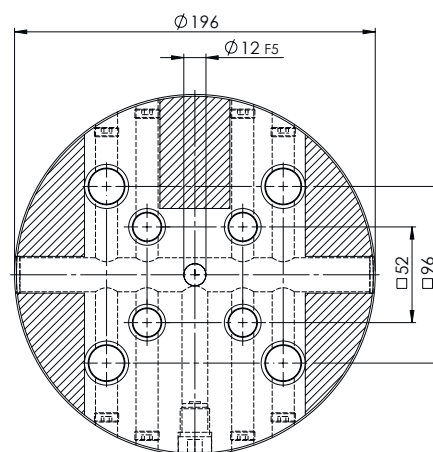

**QUICK-POINT® 52 / 96, COMBI ROUND PLATE
Ø 196 × 27 MM, WITHOUT MOUNTING BORES**

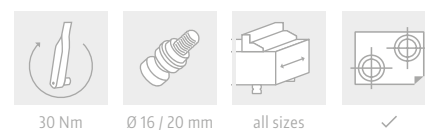

ITEM NO.	DIMENSIONS	WEIGHT
45482	Ø 196 × 27 mm	5.4 kg
45004	Set mounting bores according to customer's request	
45002	Set keyways according to customer's request	

Quick-Point® 52 / 96 combi plate / twin base

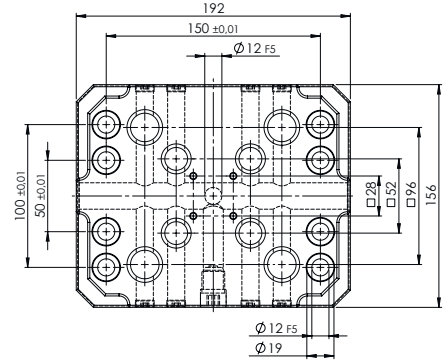

QUICK-POINT® 52 / 96, COMBI PLATE WITH CLAMPING EDGE 192 × 156 × 27 MM

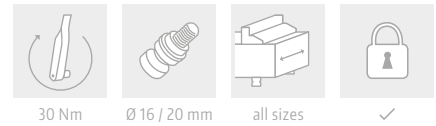

ITEM NO.	DIMENSIONS	MOUNTING BORES	WEIGHT
45448	192 × 156 × 27 mm	150 × 100 / 50 mm	4.8 kg

Suitable Quick-Lock: Item No. 44552 or 44596 (page 72).

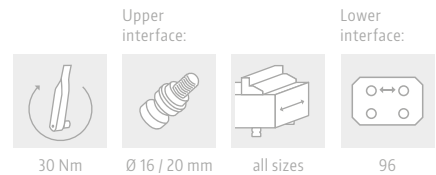
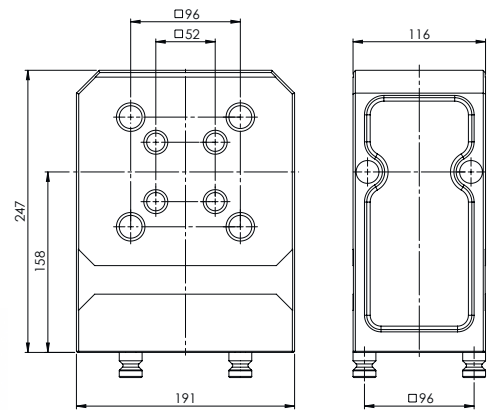

QUICK-POINT® 52 / 96, COMBI TWIN BASE

ITEM NO.	DIMENSIONS	WEIGHT
47548	192 × 116 × 247 mm	26.5 kg

Includes: 4 Quick-Point® 96 clamping studs Ø 20 mm (Item No. 45570).
 Suitable Quick-Lock: Item No. 44552 or 44596 (page 72).
 This product is also shown on page 55.

Quick·Point® 52 / 96 combi 5-axis riser

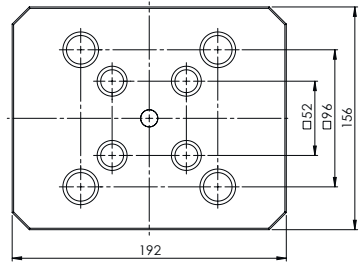
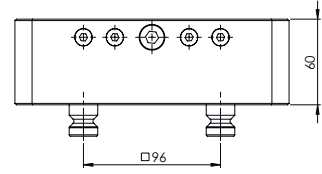

QUICK·POINT® 52 / 96, COMBI 5-AXIS RISER 192 × 156 × 60 MM

Upper interface:

Lower interface:



30 Nm



Ø 16 / 20 mm



all sizes



✓



96

ITEM NO.

DIMENSIONS

WEIGHT

45486

192 × 156 × 60 mm

10.9 kg

Includes: 4 Quick·Point® 96 clamping studs Ø 20 mm (Item No. 45570).
Suitable Quick·Lock: Item No. 44552 or 44596 (page 72).

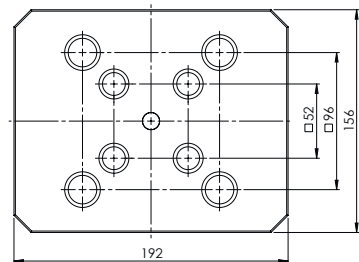
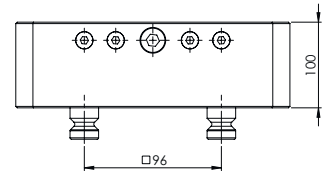

QUICK·POINT® 52 / 96, COMBI 5-AXIS RISER 192 × 156 × 100 MM

Upper interface:

Lower interface:



30 Nm



Ø 16 / 20 mm



all sizes



✓



96

ITEM NO.

DIMENSIONS

WEIGHT

45487

192 × 156 × 100 mm

17.8 kg

Includes: 4 Quick·Point® 96 clamping studs Ø 20 mm (Item No. 45570).
Suitable Quick·Lock: Item No. 44552 or 44596 (page 72).

Quick-Point® modular plates

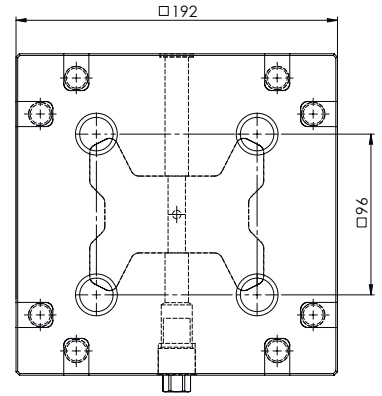

QUICK-POINT® 96, MODULAR PLATE 192 × 192 × 27 MM, WITHOUT MOUNTING BORES

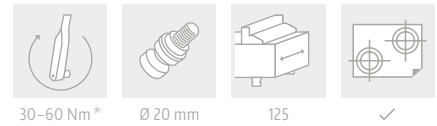

ITEM NO.	DIMENSIONS	WEIGHT
85710	192 × 192 × 27 mm	7.2 kg
45004	Set mounting bores according to customer's request	
45002	Set keyways according to customer's request	

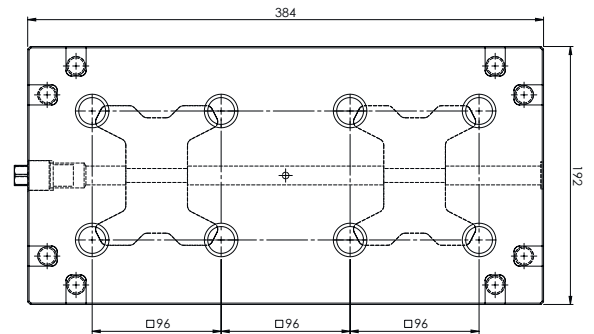

QUICK-POINT® 96, 2-FOLD MODULAR PLATE 384 × 192 × 27 MM, WITHOUT MOUNTING BORES

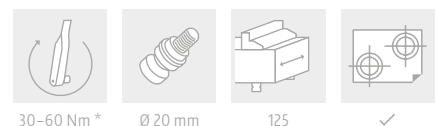

ITEM NO.	DIMENSIONS	WEIGHT
85720	384 × 192 × 27 mm	14.7 kg
45024	Set mounting bores according to customer's request	
45022	Set keyways according to customer's request	



QUICK-POINT® CONVERSION KIT FOR MODULAR PLATES

ITEM NO.	QTY	WEIGHT
85700	1 pressure bolt, 2 connectors	0.3 kg

The conversion set, which includes a pressure bolt and two connectors, is required when modular plates are to be connected in series, in order to operate the entire clamping mechanism via the tightening screw of the front modular plate. Due to the precise fit of the connectors the alignment of modular plates towards each other is no longer necessary.



QUICK-POINT® CONNECTOR SET FOR MODULAR PLATES

ITEM NO.	QTY	WEIGHT
85701	2 pcs.	0.1 kg

The connector set for the Quick-Point® modular plates is not only part of the the conversion kit (item no. 85700), but available individually, in order to connect neighboring modular plates with each other and to enable a zero point grid across the plates in x-direction. Due to the precise fit with the recesses of the zero point plate, connected modular plates no longer have to be aligned to each other.



QUICK-POINT® COVERS FOR MODULAR PLATES

ITEM NO.	QTY	WEIGHT
85702	10 pcs.	0.05 kg

The plastic covers close those recesses of the Quick-Point® modular plates to which no further modular plate is added. They are available in sets of 10. Both modular plates (Item No. 85710 and 85720) are supplied with 8 covers each.

Combination options for the modular plates

A single actuation screw can be used to clamp and release up to five clamping units simultaneously (two 2-fold modular plates + one modular plate). The single modular plate must always be placed at the rear end of the combination.

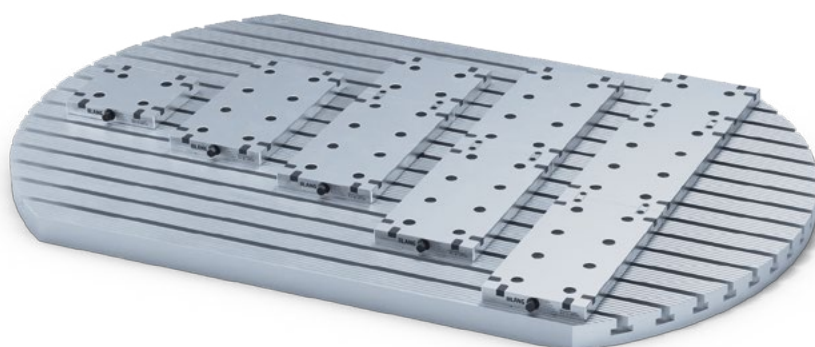

Quick-Point® adapter plates

The adapter plate emphasizes the modularity and versatility of the zero point clamping system. It facilitates the change from the large 96 mm grid size to the small 52 mm grid size if the user has not only large but also small clamping devices in use. Here, and thanks to the raised position of the clamping device, the adapter plate improves accessibility when machining small components.

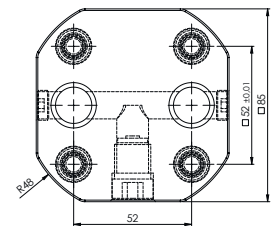
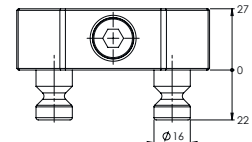
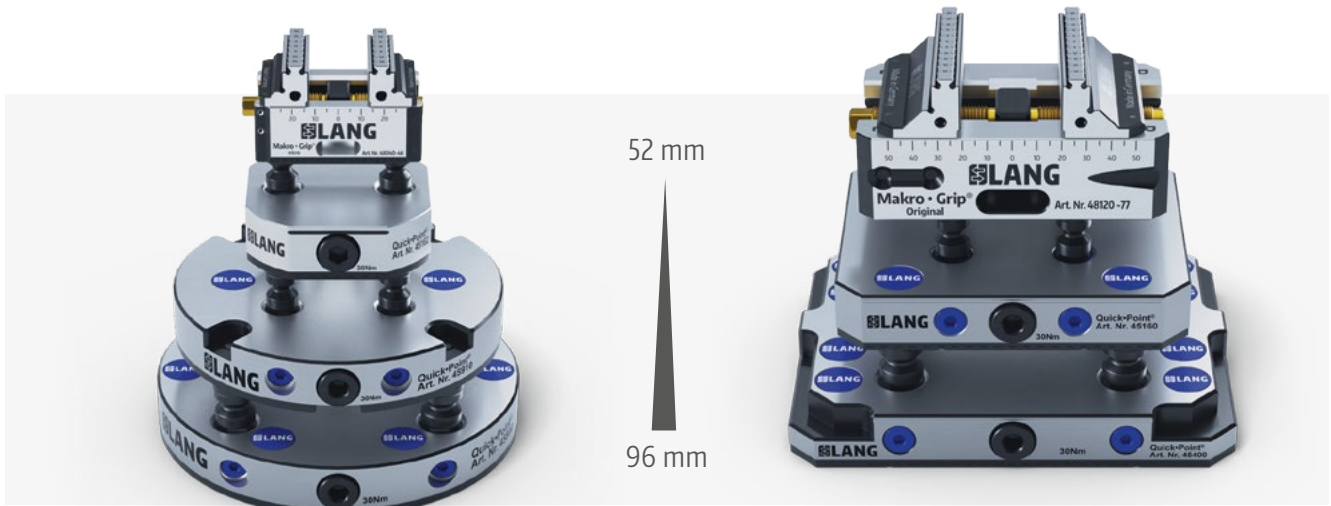

NEW

QUICK-POINT® DU02, ADAPTER PLATE 85 × 85 × 27 MM

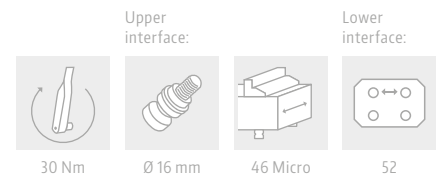

ITEM NO.	DIMENSIONS	WEIGHT
45162	85 × 85 × 27 mm	1.4 kg

Includes: 4 Quick-Point® 52 clamping studs Ø 16 mm (Item No. 45270).

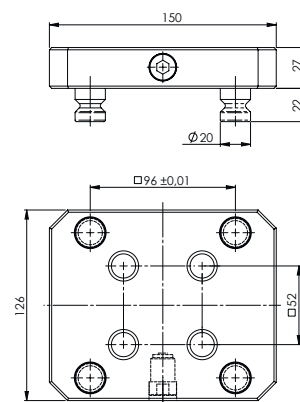

QUICK-POINT® ADAPTER PLATE
150 × 126 × 27 MM

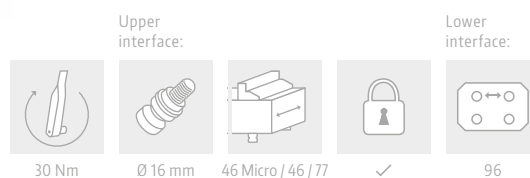

ITEM NO.	DIMENSIONS	WEIGHT
45160	150 × 126 × 27 mm	3.6 kg

Includes: 4 Quick-Point® 96 clamping studs Ø 20 mm (Item No. 45570).
 Suitable Quick-Lock: Item No. 44552 (page 72).

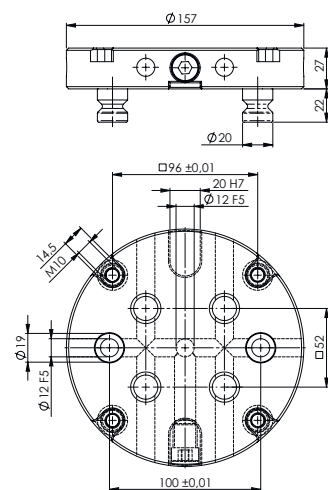

QUICK-POINT® ADAPTER PLATE, ROUND
Ø 157 × 27 MM

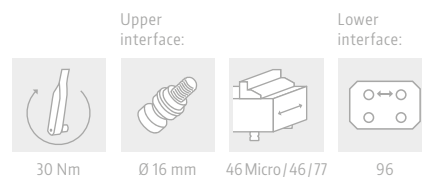

ITEM NO.	DIMENSIONS	WEIGHT
45910	Ø 157 × 27 mm	3.6 kg

Includes: 4 Quick-Point® 96 clamping studs Ø 20 mm (Item No. 45570).

Quick-Point® 5-axis risers

5-axis risers create distance between the machine table and the workpiece, which improves accessibility for 5-sided machining. The integrated clamping studs guarantee a fast and precise set-up process.



Note: Can be used with both grid sizes!

On the underside of the Quick-Point® 52, 5-axis riser, there are holes for mounting clamping studs Ø 20 mm for use in the large Quick-Point® 96 system. This means that a Quick-Point® 52, 5-axis riser can be used as an “elevated adapter”.

Applications

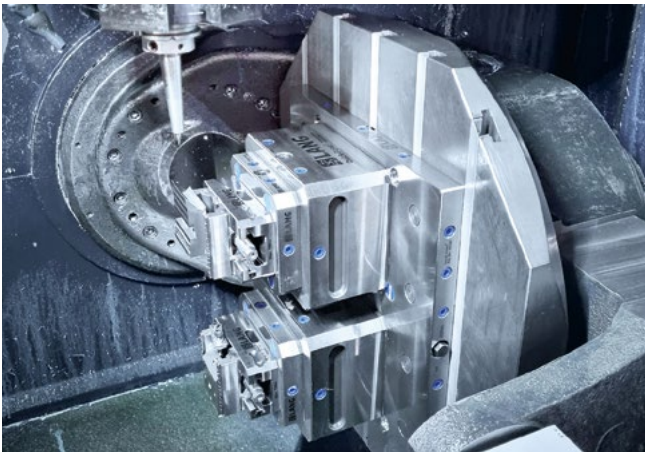

Goldbach Zerspanungs-GmbH & Co. KG

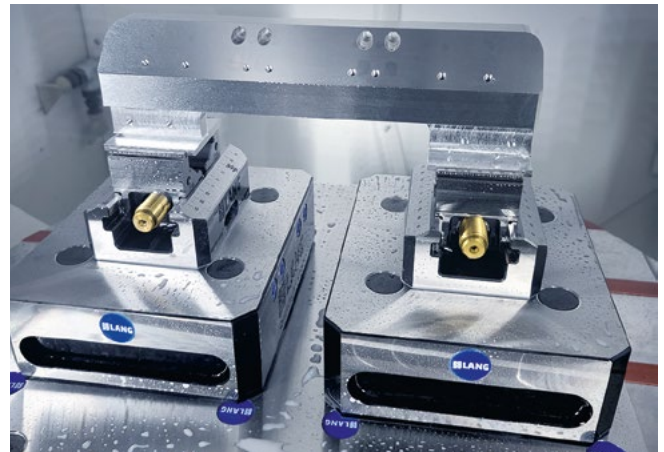

Jian Hsin Precision Machinery Co., Ltd.

Note:

Also available as combi riser!

The 5-axis risers are also available as a combi type solution with integrated 52 / 96 mm zero point grid. Both types are shown on page 45.



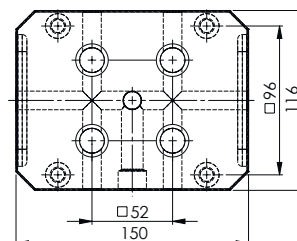
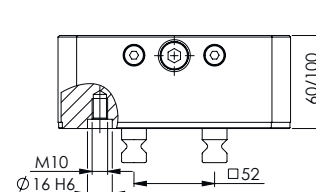

Upper interface:

Lower interface:



30 Nm

Ø 16 mm

46 Micro / 46 / 77

52 / 96

QUICK-POINT® 52, 5-AXIS RISER

ITEM NO.	DIMENSIONS	WEIGHT
45156	150 × 116 × 60 mm	6.1 kg
45157	150 × 116 × 100 mm	10.0 kg

Includes: 4 Quick-Point® 52 clamping studs Ø 16 mm (Item No. 45270).
Suitable Quick-Lock: Item No. 44552 (page 72).

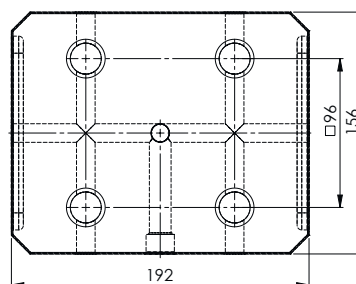
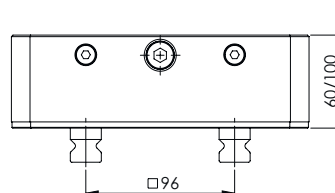

Upper interface:

Lower interface:



30 Nm

Ø 20 mm

125

96

QUICK-POINT® 96, 5-AXIS RISER

ITEM NO.	DIMENSIONS	WEIGHT
45406	192 × 156 × 60 mm	11.2 kg
45407	192 × 156 × 100 mm	18.0 kg

Includes: 4 Quick-Point® 96 clamping studs Ø 20 mm (Item No. 45570).
Suitable Quick-Lock: Item No. 44596 (page 72).

Quick-Point® spacer

The aluminium spacer improves accessibility in 5-sided machining and can either be mounted directly and firmly on the machine table or set up and removed on a zero point plate. It is available in round and rectangular versions in heights of 60 and 100 mm.

Suitable plate:



45150

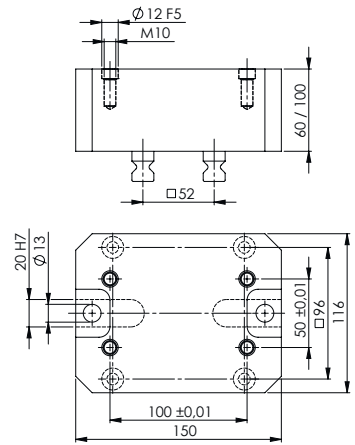

Upper interface:
45150

Lower interface:



Ø 16 mm



46Micro / 46 / 77

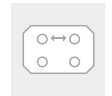

52 / 96

QUICK-POINT® 52, SPACER

ITEM NO.	DIMENSIONS	WEIGHT
43060	150 × 116 × 60 mm	2.7 kg
43100	150 × 116 × 100 mm	4.5 kg

Includes: 4 Quick-Point® 52 clamping studs Ø 16 mm (Item No. 45270), 4 × M 10 screws, 2 × Ø 12 × 12 mm bushings (Item No. 45000-09).

On the underside of the Quick-Point® spacer, there are holes for mounting clamping studs Ø 20 mm for use in the large Quick-Point® 96 system.

Mounting options



The spacer is clamped via its clamping studs in a zero point plate. This is particularly useful when the clamping situation is regularly changed.

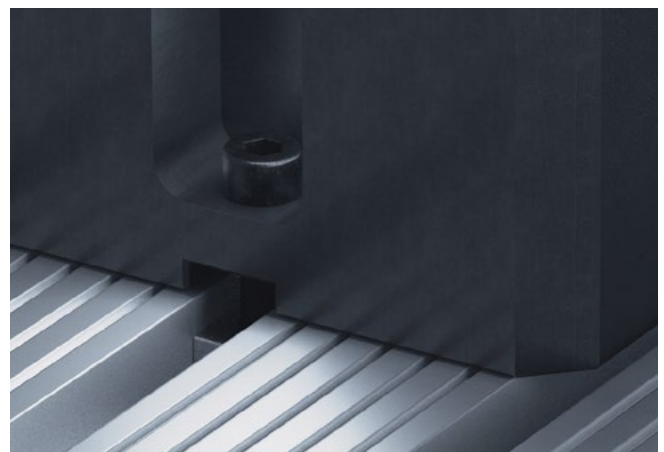

If the spacer is to remain permanently on the machine table, it can be attached directly in the slots of the machine table. In this case, a zero point plate and its added height of 27 mm can be saved.

Suitable plates:



45400



45448

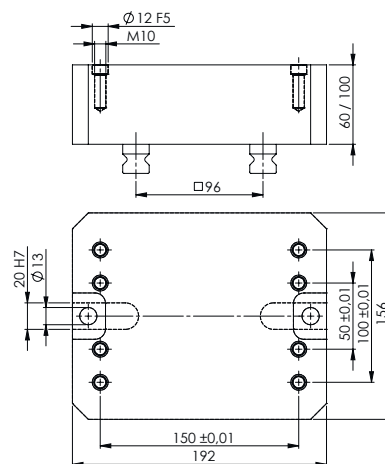

Upper interface
45400 / 45448:

Lower interface:



Ø 20 mm



125



96

QUICK-POINT® 96, SPACER

ITEM NO.	DIMENSIONS	WEIGHT
44060	192 × 156 × 60 mm	4.9 kg
44100	192 × 156 × 100 mm	8.1 kg

Includes: 4 Quick-Point® 96 clamping studs Ø 20 mm (Item No. 45570), 4 × M 10 screws, 2 × Ø 12 × 12 mm bushings (Item No. 45000-09).

Suitable plates:



45800



45480

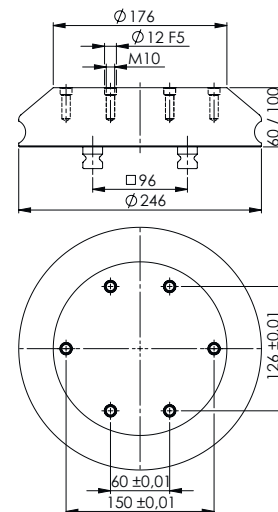

Upper interface
45800 / 45480:

Lower interface:



Ø 20 mm



125



96

QUICK-POINT® 96, SPACER, ROUND

ITEM NO.	HEIGHT	DIAMETER	WEIGHT
44006	60 mm	bottom: 246 mm, top: 176 mm	7.1 kg
44010	100 mm	bottom: 246 mm, top: 176 mm	12.4 kg

Includes: 4 Quick-Point® 96 clamping studs Ø 20 mm (Item No. 45570), 4 × M 10 screws, 2 × Ø 12 × 12 mm bushings (Item No. 45000-09).
Individual mounting bores in the sloping surface possible.

Quick-Point® 3-face pyramid

The 3-sided pyramid made of high-strength aluminium offers excellent accessibility for 5-axis machining. This multiple clamping solution is ideal for increasing the machine runtime of CNC machining centers. Thanks to the combi zero point plates with both 52 and 96 mm grid sizes, any size of LANG vise can be used for machining.

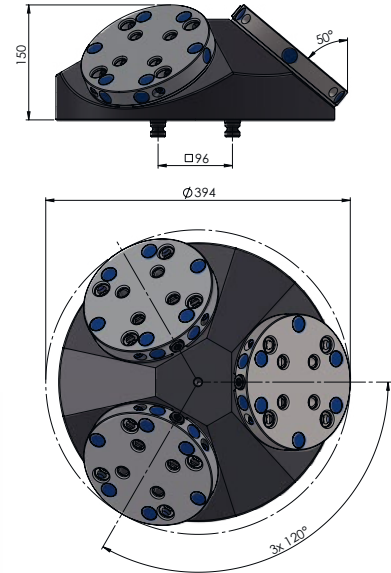

NEW VERSION

QUICK-POINT® 52 / 96, 3-FACE PYRAMID

Upper interface:		Lower interface:	
30 Nm	Ø 16 / 20 mm	all sizes	96

ITEM NO.	DIMENSIONS	WEIGHT
43360	Ø 394 × 150 mm	34.5 kg

Includes: 4 Quick-Point® 96 clamping studs Ø 20 mm (Item No. 45570).

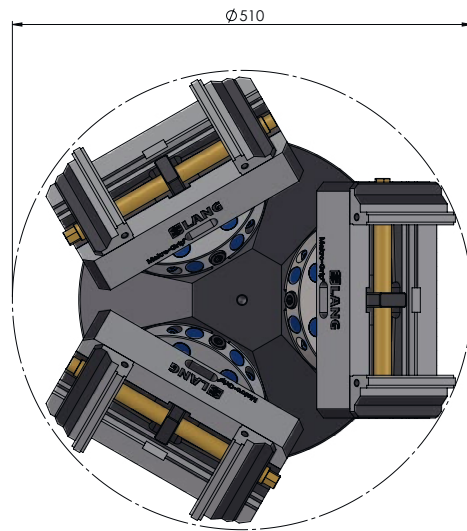
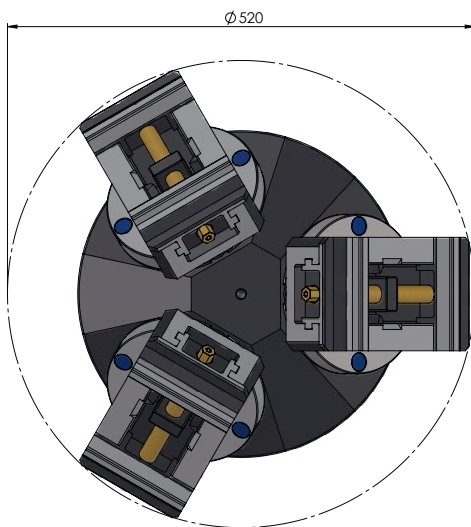

The 3-face pyramid can clamp Makro-Grip® 5-axis vises with a maximum length of 210 mm when mounted vertically (left), whereas the maximum length is 260 mm when mounted horizontally (right).

Quick·Point® twin bases

The hardened and ground twin base is ideal for manufacturing 5-axis parts with a 3-axis machine tool. Workpieces can be positioned $4 \times 90^\circ$ safely and with a high repeat accuracy.

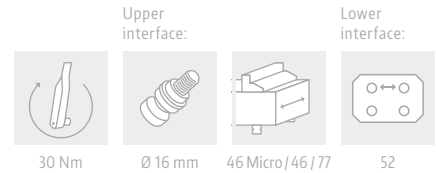
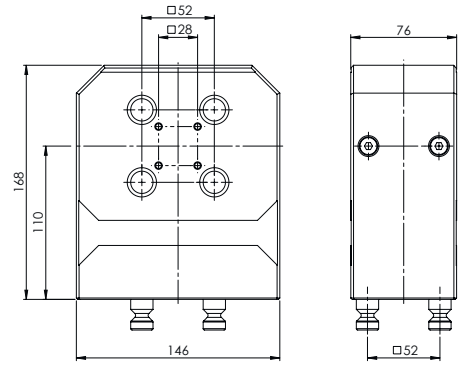

QUICK-POINT® 52, TWIN BASE

ITEM NO.	DIMENSIONS	WEIGHT
47220	146 × 76 × 168 mm	13.8 kg

Suitable Quick-Lock: Item No. 44552 (page 72).

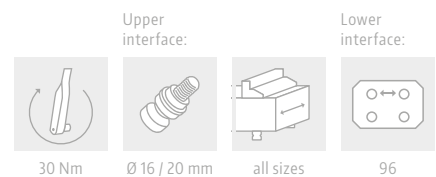
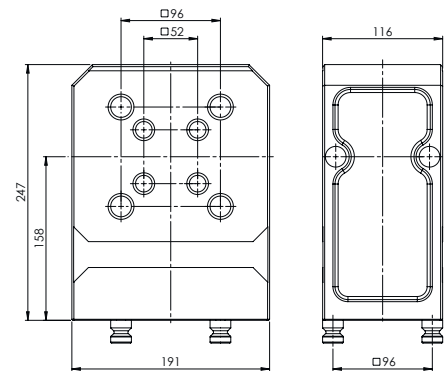

QUICK-POINT® 52 / 96, COMBI TWIN BASE

ITEM NO.	DIMENSIONS	WEIGHT
47548	192 × 116 × 247 mm	26.5 kg

Suitable Quick-Lock: Item No. 44552 or 44596 (page 72).

This product is also shown on page 44.

Quick-Point® Tri-Top 3-face tombstone

With its stable steel base body, the Tri-Top guarantees maximum precision. Despite its robustness, it is easy to handle and has the same interference contours as its predecessor. The triple zero point system can clamp Makro-Grip® 46 (Micro) and 77 vises, and reduces downtime and tool changes during milling.

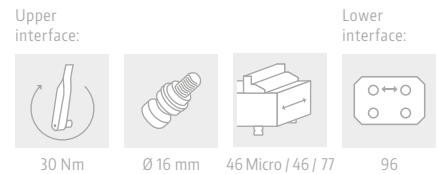
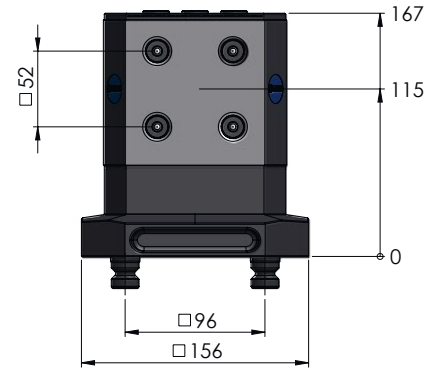
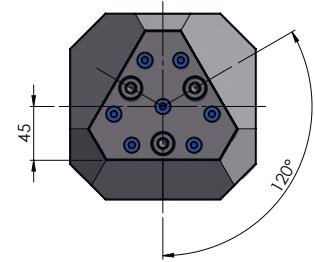

QUICK-POINT® 52, TRI-TOP 3-FACE TOMBSTONE

ITEM NO.	DIMENSIONS	WEIGHT
43352	156 × 156 × 167 mm	10.0 kg

Includes: 4 Quick-Point® 96 clamping studs Ø 20 mm (Item No. 45570).



When clamped horizontally, 3 Makro-Grip® 77, 5-axis vises with a maximum length of 130 mm can be clamped in the Tri-Top.



When clamped vertically, a maximum vise length of 170 mm is possible. Shorter lengths and smaller sizes can, of course, also be used.

Quick·Point® MT3 / MT4 tombstones

Suitable plates:

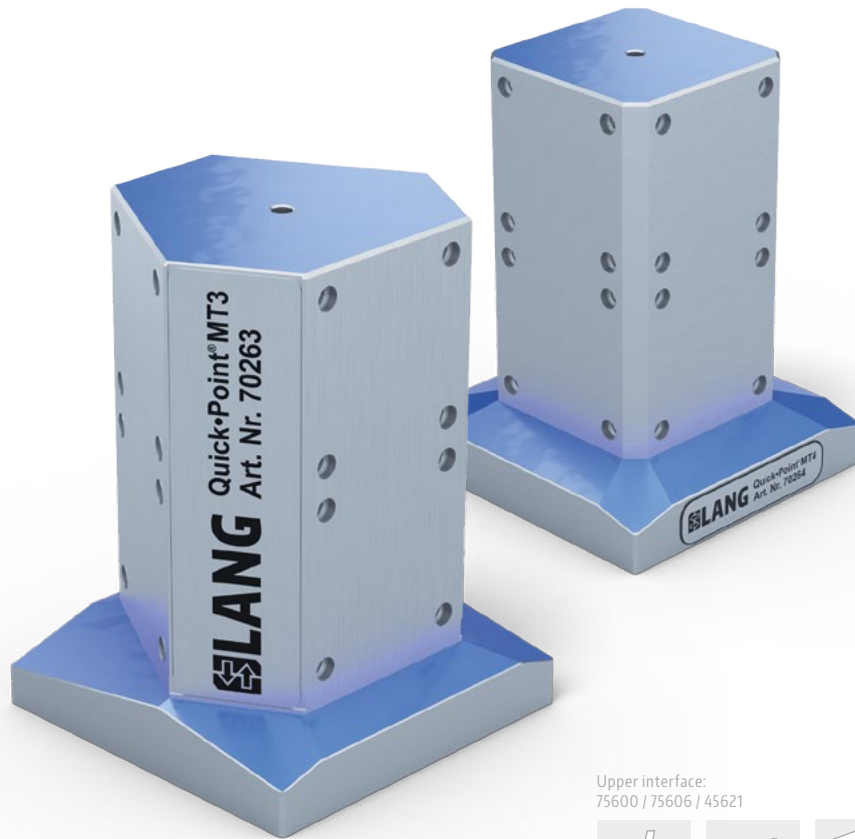

Upper interface:
75600 / 75606 / 45621



30 Nm



Ø 16 mm



46 Micro / 46 / 77

Lower interface:



96

QUICK·POINT® 52, 3- / 4-FACE TOMBSTONE

ITEM NO.	DIMENSIONS	MAX. QTY OF GRID PLATES	WEIGHT
70263	192 × 192 × 260 mm	6 × 75600 or 6 × 75606 or 3 × 45621	43.7 kg
70264		8 × 75600 or 8 × 75606 or 4 × 45621	37.1 kg

Includes: 4 Quick·Point® 96 clamping studs Ø 20 mm (Item No. 45570).

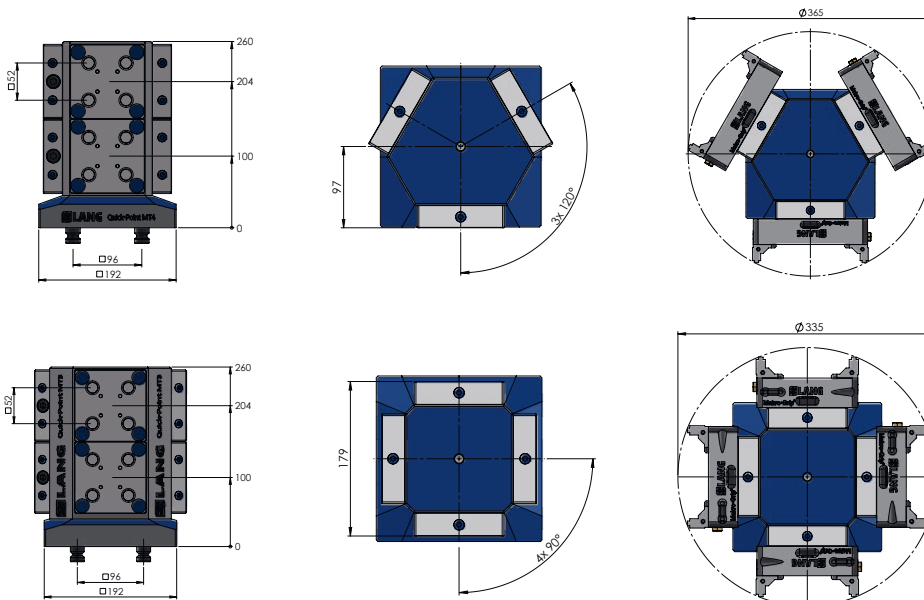

The 3-face tombstone can clamp all vises with a jaw width of 46 and 77 mm when mounted horizontally.

The 4-face tombstone can clamp vises (jaw width 46 / 77) with a max. base length of 130 mm when mounted horizontally.



LANG

Quick-Tower
Art. Nr. 70650

LANG

1001
Quick-Point®
Art. Nr. 85720

30Nm
40Nm
50Nm
60Nm

LANG

1042
Quick-Point®
Art. Nr. 85720

30Nm
40Nm
50Nm
60Nm

Quick·Tower

tombstone for horizontal machining centers

The Quick·Tower tombstone is a flexible clamping solution due to its wide range of mounting options and high storage capacity, which helps to significantly increase the machine runtimes of horizontal machining centers. The Quick·Tower is quick and easy to set up thanks to the integrated clamping studs. A wide variety of zero point plates can be attached to its four side surfaces, allowing all LANG Technik vise sizes to be used in milling operations.

Primary area of application:

- **Horizontal machining centers**
- **Single part to batch production**
- **Single and multiple clamping**

Benefits:

- **Increased machine running times thanks to multiple clamping**
- **Enormous set-up time savings when loading and setting up the tombstone**
- **High storage capacity on a small space**



Quick·Tower

Clamping options:

- direct clamping of workpieces
- LANG Technik vises
- customer-specific devices / fixtures
- vises from other manufacturers

Tombstone:

- precision-milled cast base body with ± 0.02 mm plane parallelism
- four sides per tombstone
- two different heights: 668 mm / 860 mm
- suitable for different Quick·Point® grid plates
- up to 28 zero point plates can be mounted
- continuous, cross-plate zero point grid
- equipped as standard with 12 Quick·Point® 96 clamping studs
- including an eye bolt for transport

Mounting:

- can be attached to Quick·Point® 96 multi plates
- can be attached to Quick·Tower base plates
- can be mounted directly on the machine table / pallet using customized mounting holes in the base

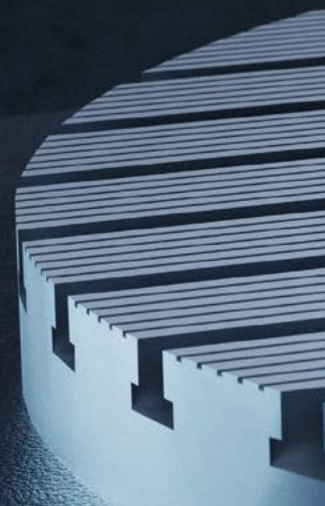

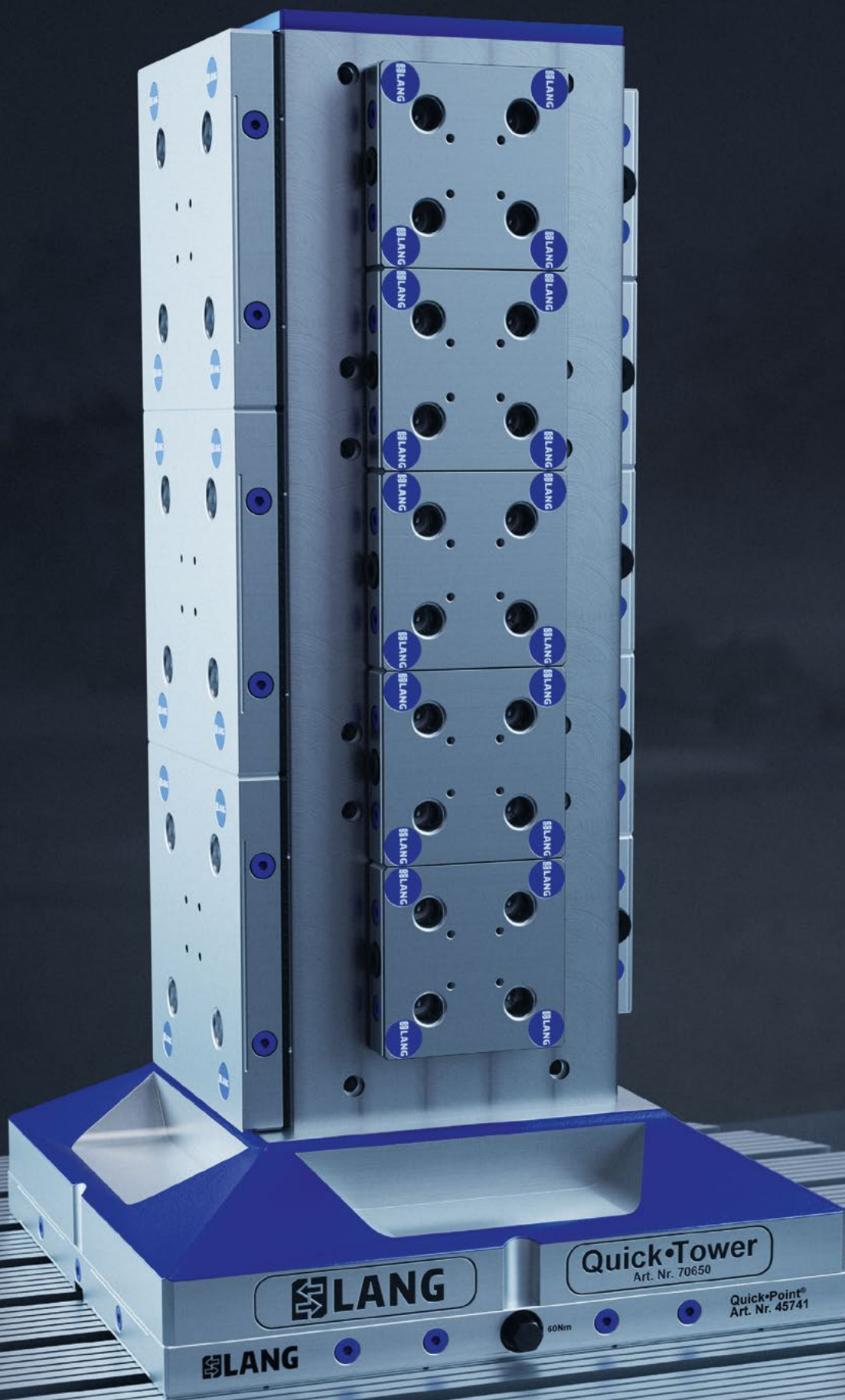

Applications

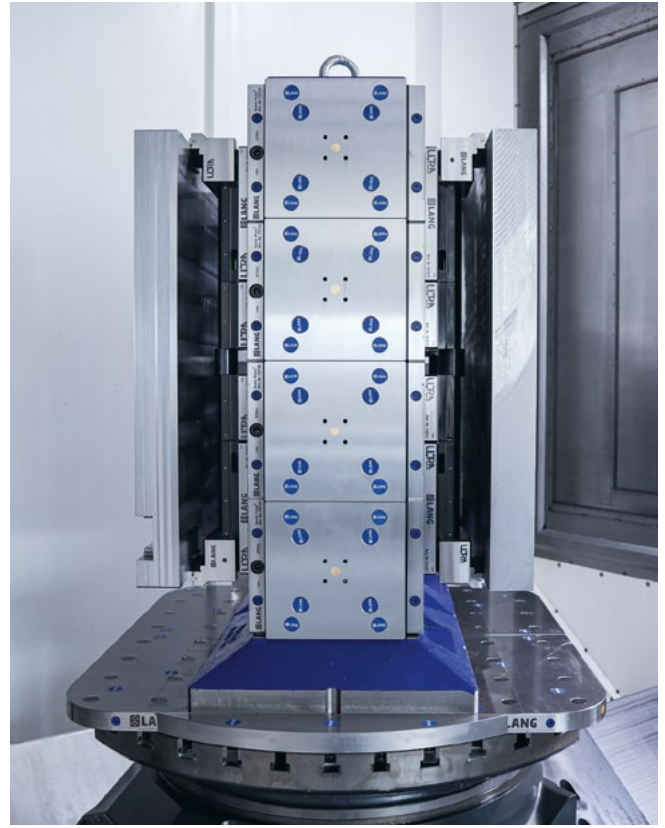
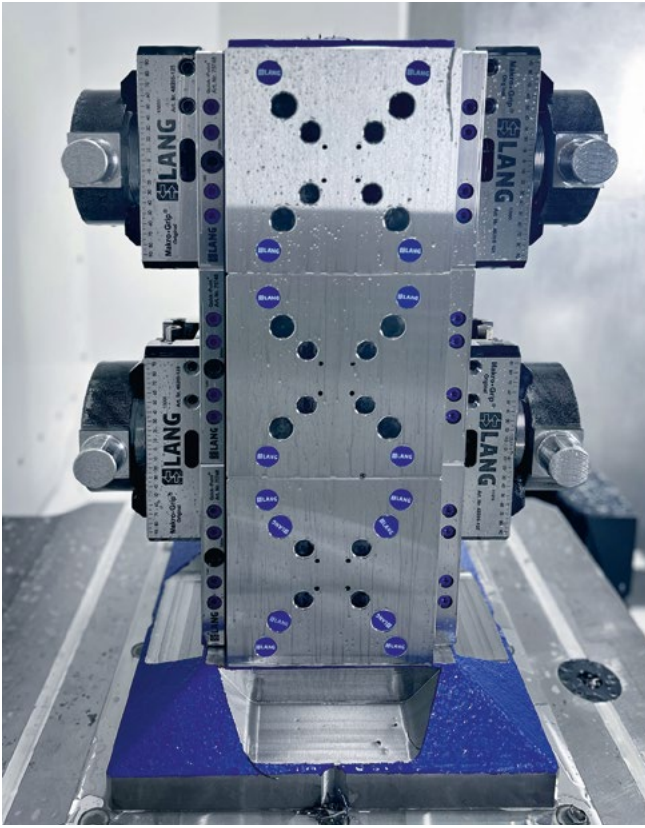

Heinrich Wagner Sinto Maschinenfabrik GmbH

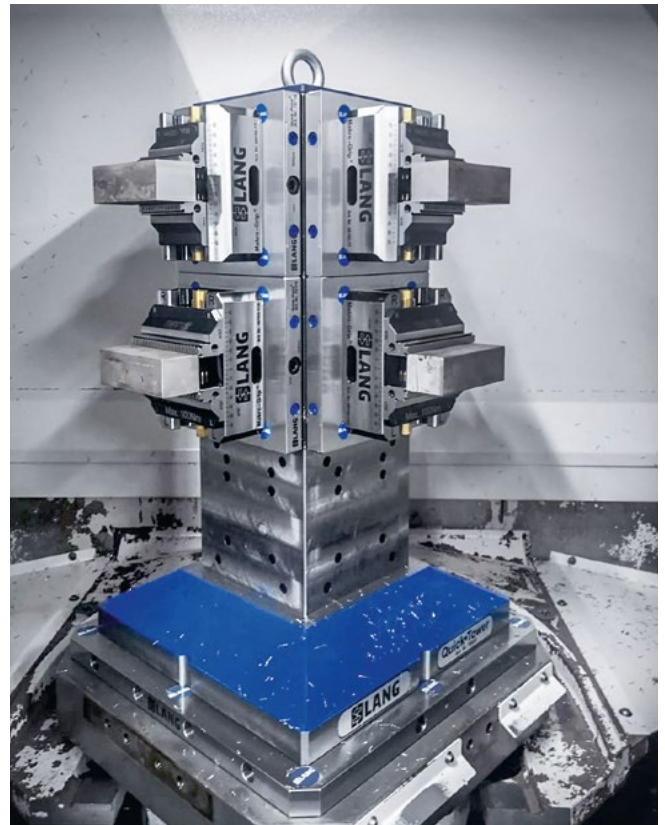
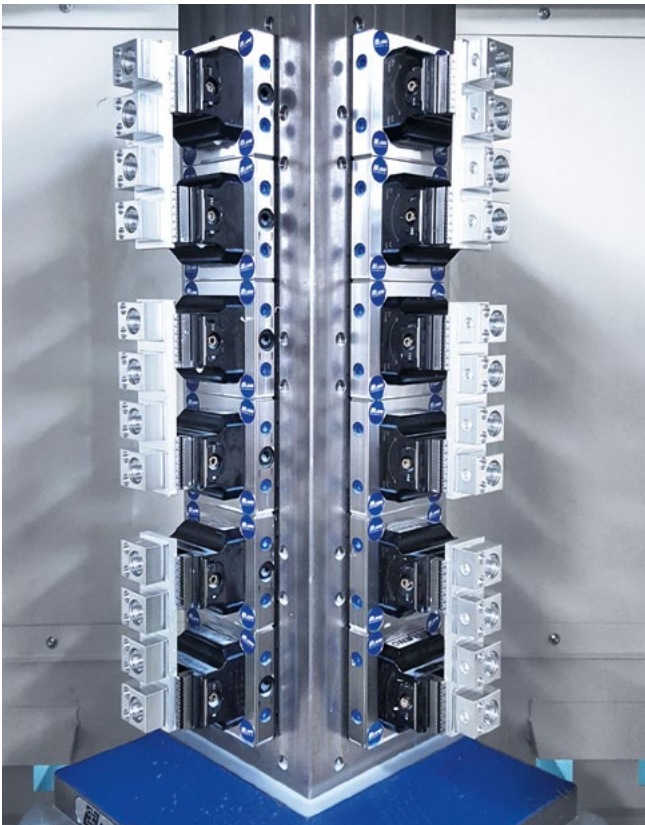

Mounting options on machine tables and pallets

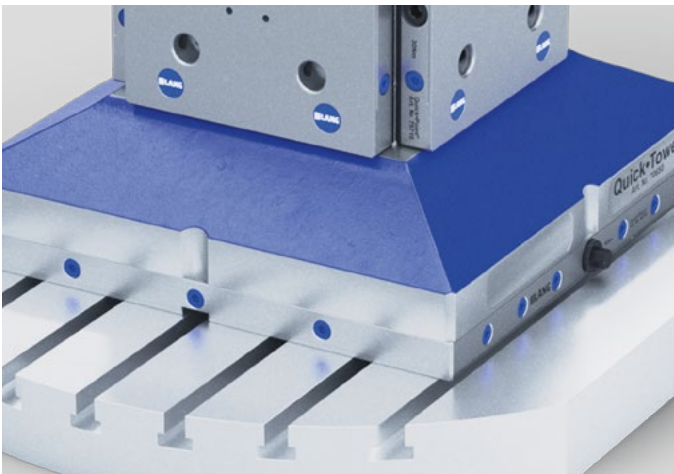

Quick-Point® 96 multi plate

One way to mount the Quick-Tower on a machine table is to use its 12 integrated clamping studs to clamp it in the Quick-Point® zero point clamping system. At least one 4-fold grid plate 96 is used as a base for this, although the machine table can also be equipped with a larger amount of zero point plates. The 4-fold grid plate 96 has identical dimensions to the Quick-Tower and thus represents a nice, flush solution. This combination is particularly suitable if a zero point clamping system is already available or if it is necessary to switch frequently and flexibly between different clamping fixtures.

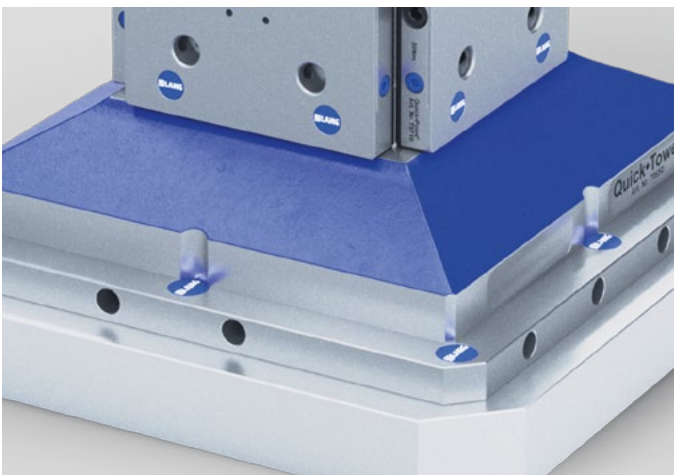

Quick-Tower base plate

The second option is to mount the Quick-Tower in one of the two available Quick-Tower base plates. The base plates are not a zero point clamping system in the true sense of the word, although the tombstone is also held in place by the 12 integrated clamping studs. The Quick-Tower is fixed in place using M16 threaded pins on the side. Base plates are a cost-effective alternative to zero point clamping systems and are particularly useful when less emphasis is placed on the precision of a zero point clamping system and when dismantling is required less frequently.

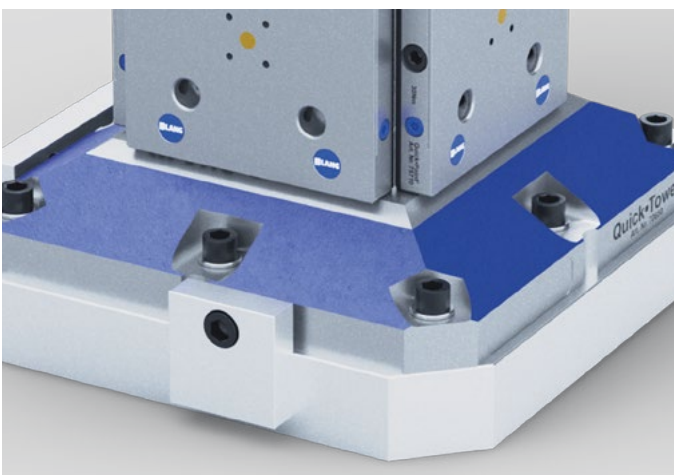

Direct mounting on machine table/pallet

If the Quick-Tower is to be fixed permanently, we recommend direct mounting without the use of a zero point or base plate. On request, mounting holes can be made in the sloping base surfaces of the tombstone to match the slots of the machine table or the holes of a pallet. This service can be provided by LANG Technik. Prices are available upon request.

Quick-Tower tombstone

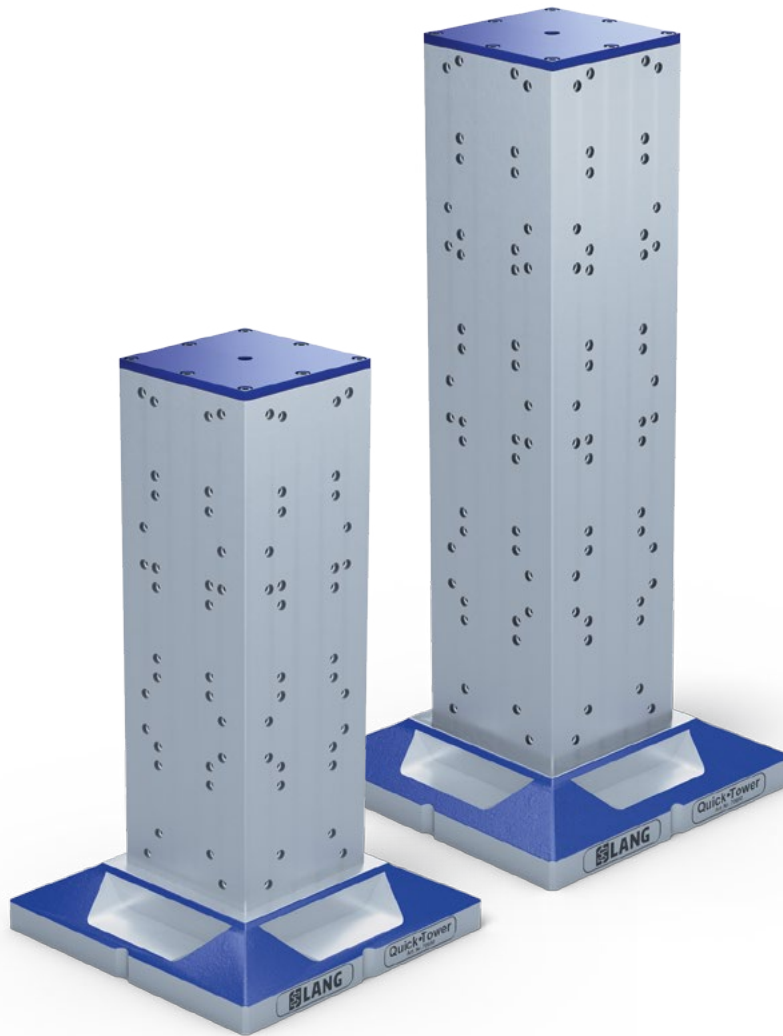

QUICK-TOWER TOMBSTONE

ITEM NO.	BODY DIMENSIONS	BASE DIMENSIONS	TOTAL HEIGHT	WEIGHT
70650	192 × 192 mm	384 × 384 mm	668 mm	164 kg
70850	192 × 192 mm	384 × 384 mm	860 mm	198 kg

If you prefer to fix the tombstone directly onto the machine table / pallet through customized mounting bores, please ask for an individual quotation.

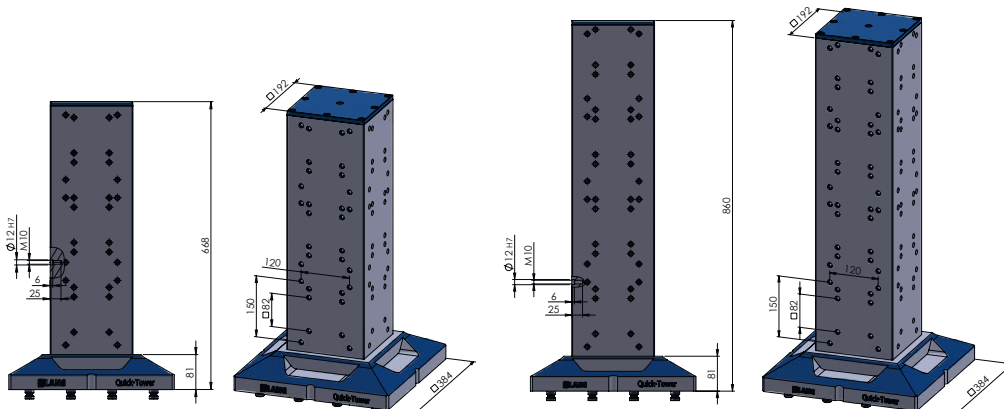

The 82 × 82 mm bore spacing is designed to mount Quick-Point® plates 75600 or 75606.

The 150 × 120 mm bore spacing is designed to mount Quick-Point® plates 75710 or 75748.

Quick·Tower base plates

These base plates serve as a connecting element between the machine table and the Quick·Tower, if the tombstone is not clamped via a zero point plate or mounted directly on the machine table.

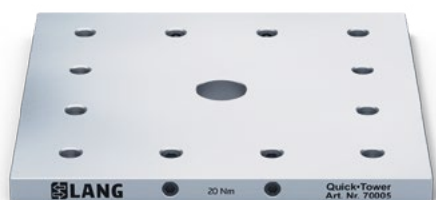

**QUICK·TOWER BASE PLATE,
THROUGH HOLE Ø 50H7, WITHOUT MOUNTING BORES**

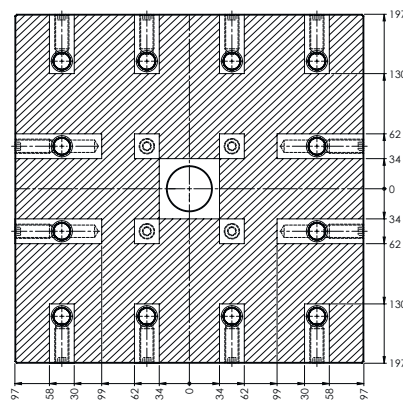

ITEM NO.	DIMENSIONS	MOUNTING BORES	WEIGHT
70005	396 × 396 × 27 mm	-	31.4 kg
70006	Set mounting bores according to customer's request		

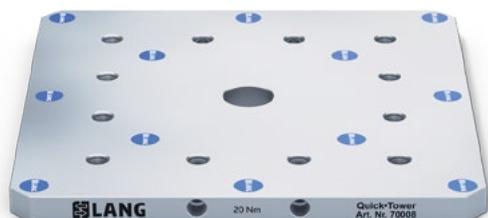

**QUICK·TOWER BASE PLATE,
THROUGH HOLE Ø 50H7, WITH MOUNTING BORES**

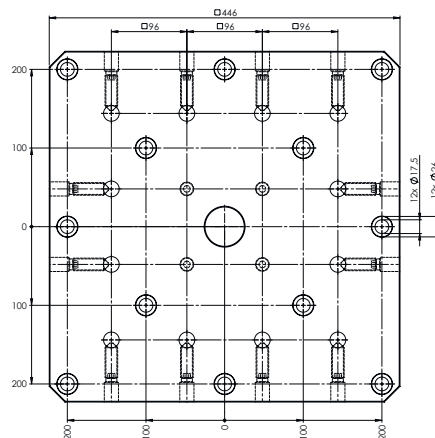

ITEM NO.	DIMENSIONS	MOUNTING BORES	WEIGHT
70008	446 × 446 × 27 mm	12 × M 16 in a 200 mm spacing	38.4 kg



Mounting and alignment

- Concentric alignment via Ø 50H7 through hole
- Axial alignment by probing the outer edges of the base
- Mounting on the machine table using DIN ISO 4762 cylinder head screws
- The tightening torque of the M 16 lateral threaded pins is 20 Nm

Quick-Point® grid plates for Quick-Tower

Included with all plates: 4 × M 10 × 35 screws,
2 × Ø 12 × 12 mm bushings (Item No. 45000-09).

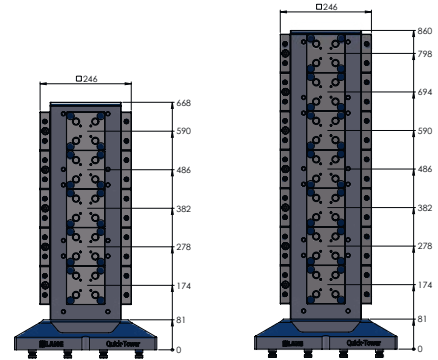

Tombstone 70650:
max. 5 plates on each face

Tombstone 70850:
max. 7 plates on each face

QUICK-POINT® 52, GRID PLATE 104 × 104 × 27 MM

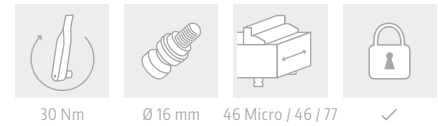

ITEM NO.	DIMENSIONS	MOUNTING BORES	WEIGHT	QTY
75600	104 × 104 × 27 mm	82 × 82 mm	1.8 kg	1 - 10
				11 - 25
				26 - 49
				from 50

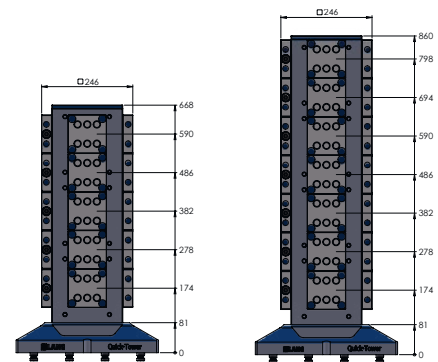

Tombstone 70650:
max. 5 plates on each face

Tombstone 70850:
max. 7 plates on each face

NEW

QUICK-POINT® 52 DUO6, GRID PLATE 104 × 104 × 27 MM

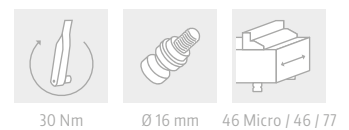

ITEM NO.	DIMENSIONS	MOUNTING BORES	WEIGHT	QTY
75606	104 × 104 × 27 mm	82 × 82 mm	1.8 kg	1 - 10
				11 - 25
				26 - 49
				from 50

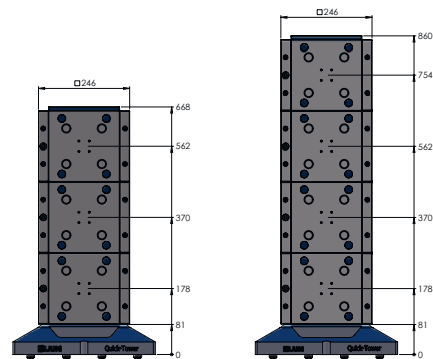

Tombstone 70650:
max. 3 plates on each face

Tombstone 70850
max. 4 plates on each face

QUICK-POINT® 96, GRID PLATE
192 × 192 × 27 MM

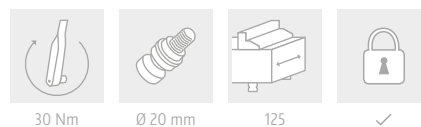

ITEM NO.	DIMENSIONS	MOUNTING BORES	WEIGHT	QTY
75710	192 × 192 × 27 mm	150 × 120 mm	7.2 kg	1 – 6
				7 – 11
				12 – 29
				from 30

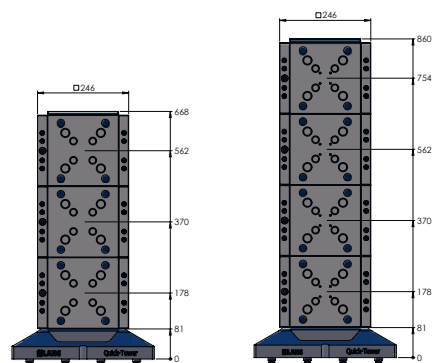

Tombstone 70650:
max. 3 plates on each face

Tombstone 70850:
max. 4 plates on each face

QUICK-POINT® 52 / 96, COMBI GRID PLATE
192 × 192 × 27 MM

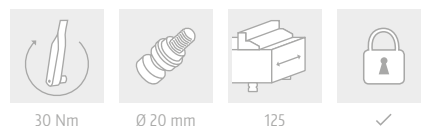

ITEM NO.	DIMENSIONS	MOUNTING BORES	WEIGHT	QTY
75748	192 × 192 × 27 mm	150 × 120 mm	6.6 kg	1 – 6
				7 – 11
				12 – 29
				from 30

Quick-Point® clamping studs

For individual adaptation of fixtures, workpieces or existing vises onto the Quick-Point® zero point clamping system.



QUICK-POINT® CLAMPING STUDS FOR INDIVIDUAL ADAPTATION

ITEM NO.	DIAMETER	QTY
45270	Ø 16 mm for 52 mm spacing, incl. M 8 × 1.25 threaded pin	1 pc.
45570	Ø 20 mm for 96 mm spacing, incl. M 10 × 1.5 threaded pin	1 pc.

Up to 4 clamping studs can be clamped in a single plate, up to 8 clamping studs in a 2-fold plate and up to 16 clamping studs in a 4-fold plate.

Installation of clamping studs:

The holes for mounting Quick-Point® clamping studs must be placed at 52 or 96 mm ± 0.01 mm.

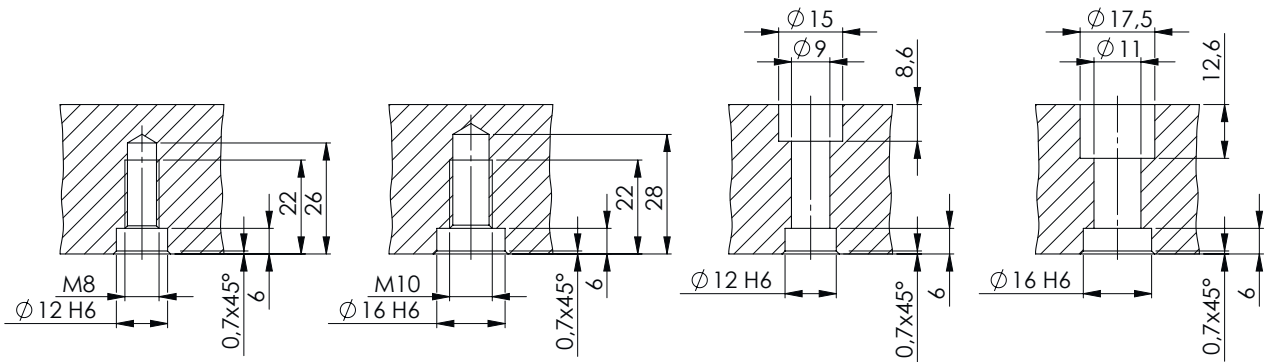

with threaded pins

with screws



52

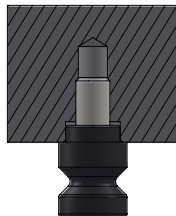

96

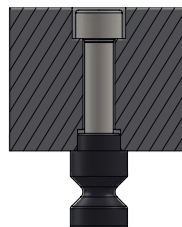

52

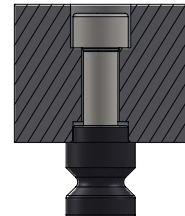

96

Applications



Not only highly precise, but also highly resilient. Four clamping studs are screwed directly into the workpiece, which weighs about 50 kg.



Direct clamping of a gearbox via four clamping studs with over 80% material removal.



Billet oil pan from the motor sports sector, clamped to a Quick-Point® multi plate by clamping studs for machining.

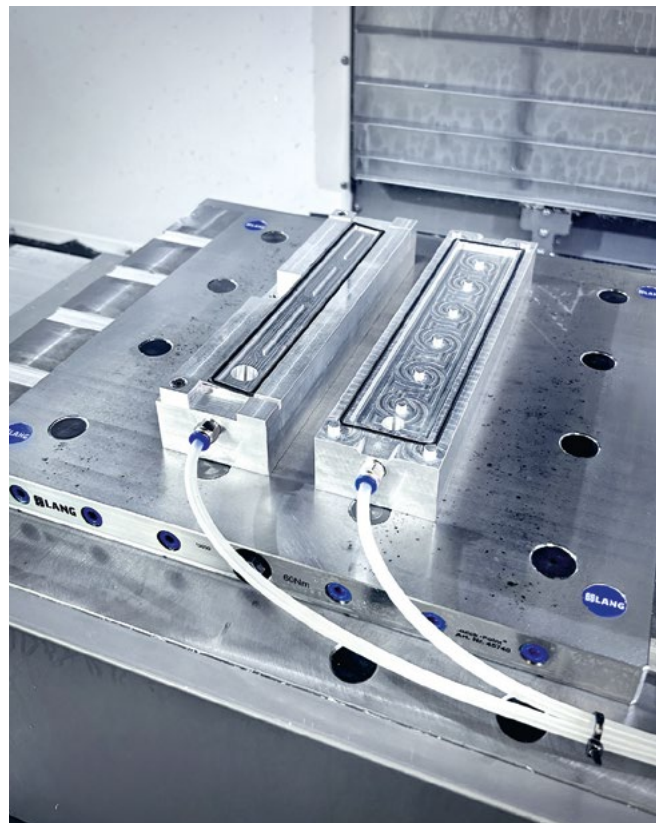

In the zero point clamping system, customer-specific devices, such as these two vacuum clamping devices, can also be set up precisely and in the least amount of time.

Quick-Point® spacer studs

Spacer studs allow for through holes in material which is clamped directly in the zero point system. It also improves accessibility when machining edges and angles.



QUICK-POINT® SPACER STUDS

ITEM NO.	DIAMETER	SPACER HEIGHT	QTY
45270-10	Ø 16 mm for 52 mm spacing	10 mm (Ø 24 mm)	4 pcs.
45570-10	Ø 20 mm for 96 mm spacing	10 mm (Ø 28 mm)	4 pcs.

Installation of spacer studs:

The holes for mounting Quick-Point® spacer studs must be placed at 52 or 96 mm ± 0.01 mm.

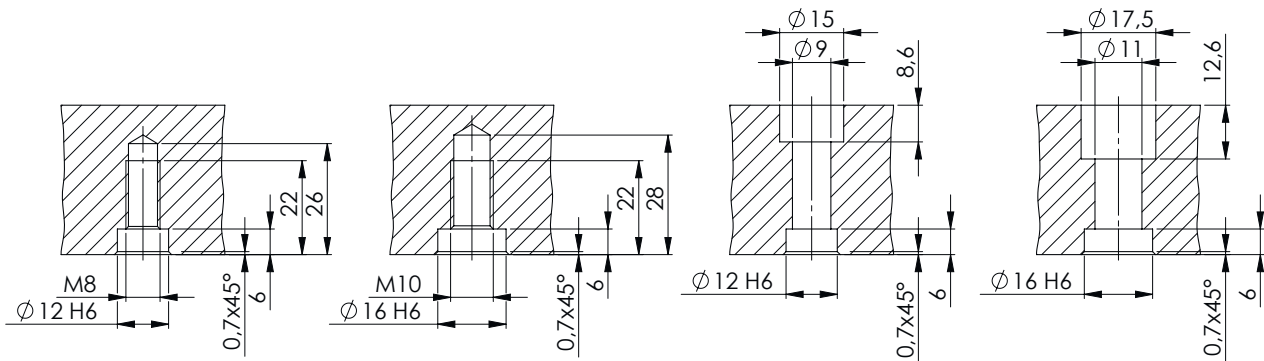

with threaded pins

with screws

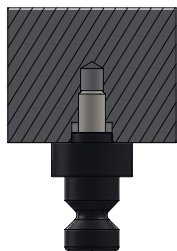

52

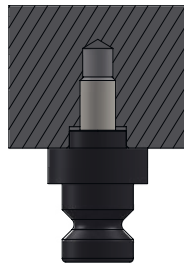

96



52

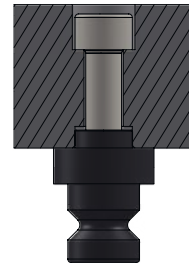

96

Quick-Point® support plates

Support plates made of non-hardened steel – for individual adaptation of fixtures and other devices.

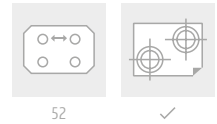

QUICK-POINT® 52, SUPPORT PLATE

ITEM NO.	DIMENSIONS	WEIGHT
45275	96 × 96 × 27 mm	2.0 kg
45277	156 × 156 × 27 mm	5.2 kg

Includes: 4 Quick-Point® 52 clamping studs Ø 16 mm (Item No. 45270).

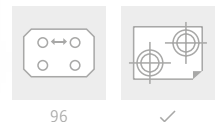

QUICK-POINT® 96, SUPPORT PLATE

ITEM NO.	DIMENSIONS	WEIGHT
45575	156 × 156 × 27 mm	5.3 kg
45577	192 × 192 × 27 mm	7.9 kg

Includes: 4 Quick-Point® 96 clamping studs Ø 20 mm (Item No. 45570).

Quick-Point® Quick-Lock fastener

The mechanical quick release fastener allows various Quick-Point® products to be quickly and effortlessly clamped and released.



QUICK-POINT® QUICK-LOCK 52

ITEM NO.	SUITABLE FOR ITEM NO.	WEIGHT
44552	45150 / 45151 / 45156 / 45157 / 45160 / 45448 / 45486 / 45487 / 45600 / 45748 / 47220 / 75600 / 75748	0.6 kg
45252	45621	1.4 kg
45452	45640 / 45641	1.4 kg

Included in delivery: 1 × clamping lever and 4 × washers to adjust clamping force if needed.

QUICK-POINT® QUICK-LOCK 96

ITEM NO.	SUITABLE FOR ITEM NO.	WEIGHT
44596	45400 / 45401 / 45406 / 45407 / 45448 / 45486 / 45487 / 45710 / 45715 / 45716 / 45720 / 45748 / 45763 / 47548 / 75710 / 75748	0.6 kg
45296	45720	1.4 kg
45996	45962 / 45963 / 45964	1.6 kg

Included in delivery: 1 × clamping lever and 4 × washers to adjust clamping force if needed.

Easy assembly in a few steps

Within just a few seconds the Quick-Lock fastener is mounted to a Quick-Point® plate. With a 180° motion of the lever the Quick-Lock clamps and releases the vise.



Removal of the actuation screw:

Remove actuation screw and the two plastic covers and keep them safe. With multi fold plates you also have to remove the actuation bolt. During the whole installation process the Quick-Point® plate does not have to be removed from the machine table if already mounted.



Installation of the Quick-Lock fastener:

Insert the Quick-Lock pressure bolt into the actuation screw channel and tighten the two screws.



Checking the clamping force:

Insert the clamping lever into the clamping element of the Quick-Lock fastener. Move the clamping lever in a 180° motion from right to left until you feel resistance. If the remaining angle is more/less than 70°, the clamping force needs to be adjusted by adding/removing washers.

Quick-Lock utilization

The clamping lever equipped with a rotation lock can be used both horizontally and vertically.

For vises and fixtures protruding from the Quick-Point® plate, the lever is used horizontally.

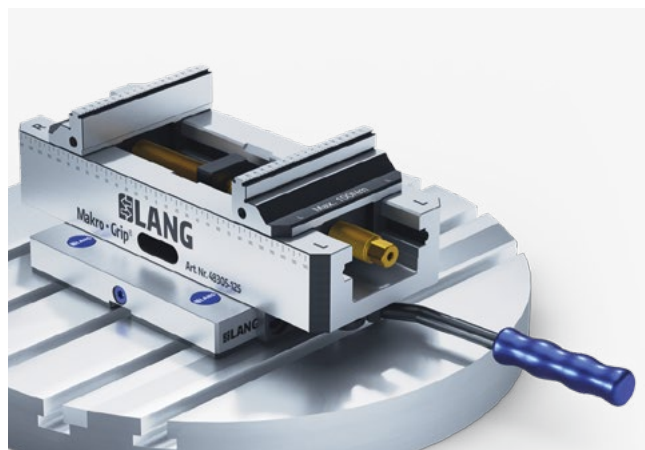

Quick-Point® accessories



QUICK-POINT® COVER DISCS, PLASTIC

ITEM NO.	DIAMETER	UNIT
45008-15	Ø 15 mm	1 set (20 pcs.)
45008-20	Ø 20 mm	1 set (20 pcs.)
45008-27	Ø 27 mm	1 set (20 pcs.)

Heat-resistant, fibreglass reinforced cover discs for protecting the mounting screws against pollution.



QUICK-POINT® COVER PLUGS, PLASTIC

ITEM NO.	DIAMETER	UNIT
45052-20	Ø 16 mm for 52 mm spacing	1 set (4 pcs.)
45096-20	Ø 20 mm for 96 mm spacing	1 set (4 pcs.)

Cover plugs made of plastic for the protection of the clamping stud holes when not in use. For multi fold plates steel plugs (see below) are necessary.



QUICK-POINT® COVER PLUGS, STEEL

ITEM NO.	DIAMETER	UNIT
45052-30	Ø 16 mm for 52 mm spacing	1 set (4 pcs.)
45096-30	Ø 20 mm for 96 mm spacing	1 set (4 pcs.)

Cover plugs made of steel spread the increased clamping force of multi grid plates evenly and protect clamping holes not in use. They can be removed from plates with the cover plug remover.



QUICK-POINT® COVER PLUG REMOVER

ITEM NO.	DESCRIPTION
45000-30	Cover Plug Remover

Convenient grip with magnet for removing steel plugs from the Quick-Point® plates and / or threaded caps of the Makro-Grip® Ultra system.



QUICK-POINT® HANDLE, ALUMINIUM

ITEM NO.	FOR
66605	Quick-Point® 52
46081	Quick-Point® 96

This handle facilitates the handling of Quick-Point® devices when setting up and dismantling. As with usual LANG clamping devices, the handle is clamped with two Quick-Point® clamping studs in the zero point system and is thereby especially suited for the transportation of heavier Quick-Point® products.

Quick-Point® alignment accessories

SLOT KEYS, LOOSE, DIN 6323, FOR AXIAL ALIGNMENT OF QUICK-POINT® PLATES



ITEM NO.	SIZE	UNIT
452014	20 to 14 mm	1 pc.
452018	20 to 18 mm	1 pc.

To make the assembly and alignment of the Quick-Point® plates as easy as possible, we offer slot keys for the plates' 20H7 keyways matching your table's t-slots (14 or 18 mm).

Attention: Keys not suitable for Item No. 45800, 45480 and 45890!

SLOT KEYS FOR AXIAL ALIGNMENT OF QUICK-POINT® ROUND PLATE, ITEM NO. 45890 (PAGE 36)

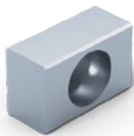

ITEM NO.	DIMENSIONS	UNIT
452214	14 × 22 mm	1 pc.
452218	18 × 22 mm	1 pc.

For the alignment of Quick-Point® plate, Item No. 45890, which has 14 & 18 H7 grooves in the bottom, we offer these keys. Grooves and keys are equipped with a M6 thread, suitable for screws DIN 84 or DIN 912, M6 × 16.

CENTERING STUDS FOR CONCENTRIC ALIGNMENT OF QUICK-POINT® PLATES



ITEM NO.	SIZE	UNIT
451230	12 to 30 mm	1 pc.
451232	12 to 32 mm	1 pc.
451250	12 to 50 mm	1 pc.
452530	25 to 30 mm	1 pc.
452532	25 to 32 mm	1 pc.
452550	25 to 50 mm	1 pc.
455030	50 to 30 mm	1 pc.
455032	50 to 32 mm	1 pc.
455050	50 to 50 mm	1 pc.

For the concentric alignment of Quick-Point® plates via fitting bores in the bottom (12, 25, 50 mm) we offer centering studs for the most common machine table holes (30, 32, 50 mm).

BUSHINGS FOR THE ALIGNMENT OF VISES AND ZERO POINT PLATES



ITEM NO.	DIMENSIONS	FOR SCREW SIZE	UNIT
45000-09	Ø 12 × 12 mm	M 10	1 pc.
65191-04	Ø 12 × 12 mm	M 8	1 pc.
65191-05	Ø 16 × 15 mm	M 10	1 pc.

Item No. 45000-09 is suitable for aligning Quick-Point® plates on aluminium risers, Quick-Tower tombstones and other applications. Bushings 65191-04 and 65191-05 are used for the alignment and mounting of Makro-Grip® 5-axis vises on (old) LANG automation support pallets Item No. 65190 and 65197.

Quick·Point® gauging pallet

Jig-ground gauging pallet for a quick and precise alignment of Quick·Point® plates. Recommended especially for rotary tables or chucks.

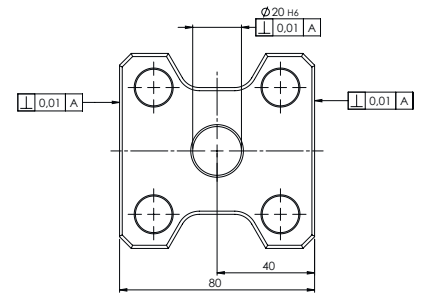
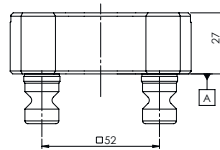

QUICK·POINT® 52 GAUGING PALLET

ITEM NO.	DIMENSIONS	MEASURING LENGTH	WEIGHT
44522	80 × 80 × 27 mm	70 mm per side	1.2 kg

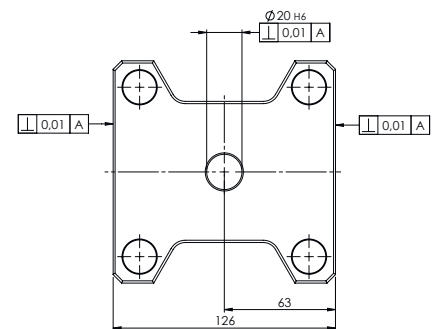
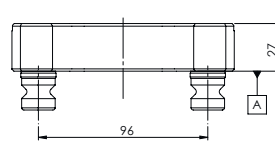

QUICK·POINT® 96 GAUGING PALLET

ITEM NO.	DIMENSIONS	MEASURING LENGTH	WEIGHT
44962	126 × 126 × 27 mm	116 mm per side	2.8 kg

How it works:

After clamping the gauging pallet in a Quick·Point® plate, alignment is done by probing the jig-ground sides of the gauging pallet. For concentric alignment the inner diameter of the gauging pallet can be used.



Quick·Point® alignment gauge

For easy and quick assembly of the Quick·Point® grid plates we recommend using the alignment gauge. The precise alignment and dimensional accuracy of the plates is guaranteed.

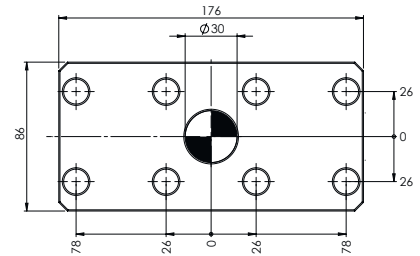

QUICK·POINT® 52 ALIGNMENT GAUGE FOR GRID PLATES

ITEM NO.	DESCRIPTION	WEIGHT
44521	Alignment gauge 52	2.8 kg
44521-10	Alignment gauge 52 for rent	-

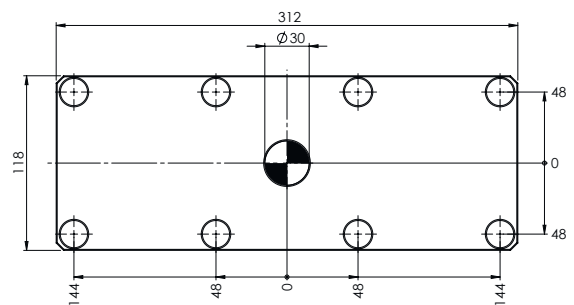

QUICK·POINT® 96 ALIGNMENT GAUGE FOR GRID PLATES

ITEM NO.	DESCRIPTION	WEIGHT
44961	Alignment gauge 96	6.8 kg
44961-10	Alignment gauge 96 for rent	-

How it works:

The Quick·Point® alignment gauge guarantees an accurate alignment of two or more grid plates positioned next to each other. This ensures that vises and fixtures can be clamped across two different plates. After the first plate is placed on the table, aligned with a probe and the screws fixed, the alignment gauge is applied on the neighboring plates and the outer accessible fixing screws can be tightened.



Quick-Point® service

Set mounting bores

All of our Quick-Point® plates with prefabricated mounting bores are also available without such. The case-hardened zero point plates (57 HRC, 0.7 mm deep) can be drilled according to the t-slots of the machine table. We offer this as a service.

The drawings of the Quick-Point® plates without mounting

bores in this catalog show hatched areas. These areas can be used for mounting bores. On rare occasions mounting bores can even be set through rod channels. If this might be required for your application please ask your local LANG contact person. All drawings are available on our website www.lang-technik.de.

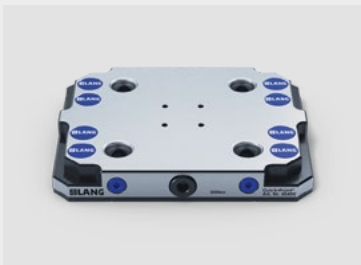

Quick-Point® plate with prefabricated mounting bores.



Same Quick-Point® plate without mounting bores. These can be installed by LANG or the customer.

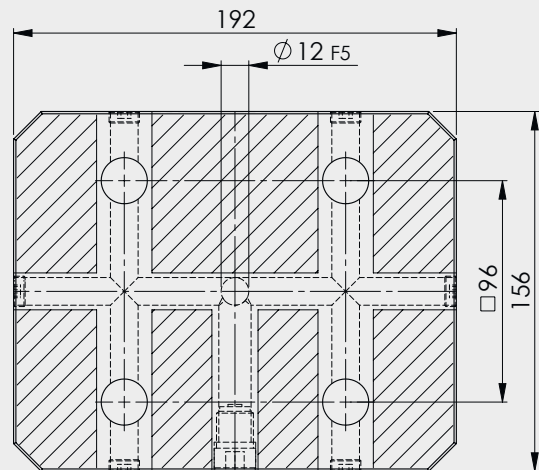

M5 Index bores

Inserting a threaded pin or screw ensures that LANG clamping devices (with an equivalent recess on the bottom) are always positioned in the same way on the zero point plate. By default index

bores are included in following Quick-Point® products: Item No. 45150, 45400, 75600, 75710 and 47220.

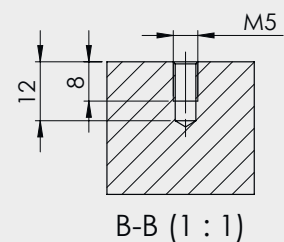
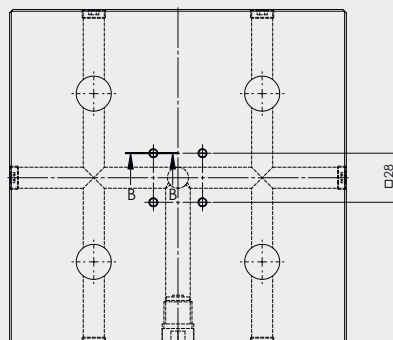
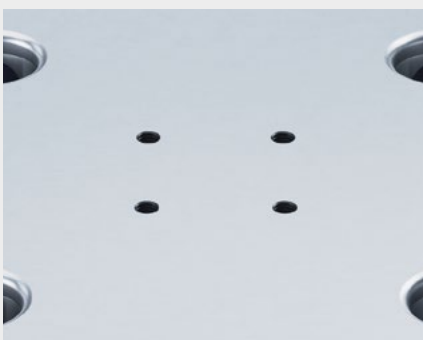

Covering mounting bores



Quick-Point® plate with plastic cover discs.

Mounting bores in Quick-Point® plates, either prefabricated or customized by LANG, have a 2.1 mm step. Plastic discs can be inserted and act as covers to prevent swarf or chips from clogging these bores. Plastic discs are available in three different diameters \varnothing 15 mm, \varnothing 20 mm and \varnothing 27 mm (see page 74).

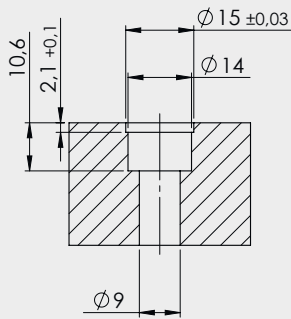

M8

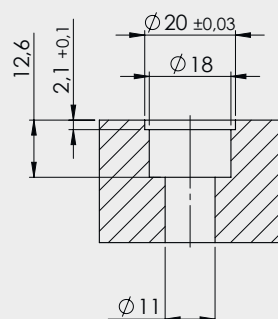

M10

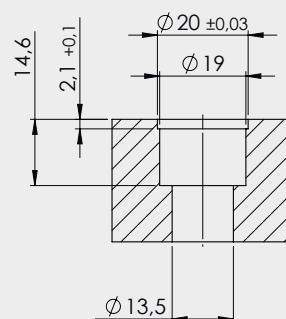

M12

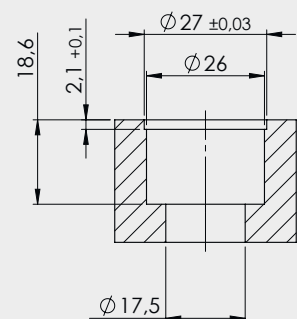

M16

Custom corner radius for Quick-Point® grid / multi-fold plates

Upon request, we can adjust the zero point system (multi-fold or individual grid plates in a row) to round tables of the machine tool

by cutting off the corners. A neat solution that in most cases prevents the zero point plates from overhanging the table.



Individual Zerspanung Thiem

CUSTOM CORNER RADIUS FOR QUICK-POINT® GRID / MULTI-FOLD PLATES

ITEM NO.	QTY
45043-01	Cut off 1 corner
45043-02	Cut off 2 corners
45043-04	Cut off 4 corners



PATENT PENDING

Quick·Point® Rail

quick clamping system

The Quick·Point® Rail is an innovative quick clamping system based on expandable clamping bars that are attached directly to grooved machine tables or automation pallets – without an additional base plate or modification to the table or pallet. Zero point risers or vises can be flexibly positioned in series on the clamping bars. This allows clamping tasks to be solved individually and cost-effectively. The Quick·Point® Rail quick clamping system guarantees extremely fast set-up speed and flexibility.

Primary area of application:

- **Manual and automated machining processes**
- **3-axis / 5-axis tables, automation pallets, trunnions and tombstones**
- **Single and multiple clamping**

Benefits:

- **Enormous time savings during set-up – system installation within 2 minutes**
- **High cost saving potential due to the elimination of zero point base plates**
- **Versatile utilization of vises and risers thanks to flexible positioning**



Quick·Point® Rail

Clamping options:

- 5-axis combi risers, two different heights for clamping:
 - direct clamping of workpieces
 - LANG Technik vises
 - customer-specific devices / fixtures
 - vises from other manufacturers
- Quick·Point® Rail centering vise, two different lengths suitable for clamping jaw types:
 - Makro·Grip® (FS), Makro·4Grip, Avanti, Profilo, Vario·Tec

Clamping bar:

- made of hardened steel
- single-sided serration with 4 mm grid
- locking points at 96 mm intervals
- positioning accuracy < 0.005 mm
- flexibly expandable in x-axis direction using extension bars
- consistent 4 mm grid over several bars
- clamping devices are fixed by pull-down effect on the dovetail guide
- available with and without predefined mounting holes
- integrated alignment slots and keyways

Mounting:

- direct mounting in the grooves of a machine table
- direct mounting in the threaded holes of an automation pallet



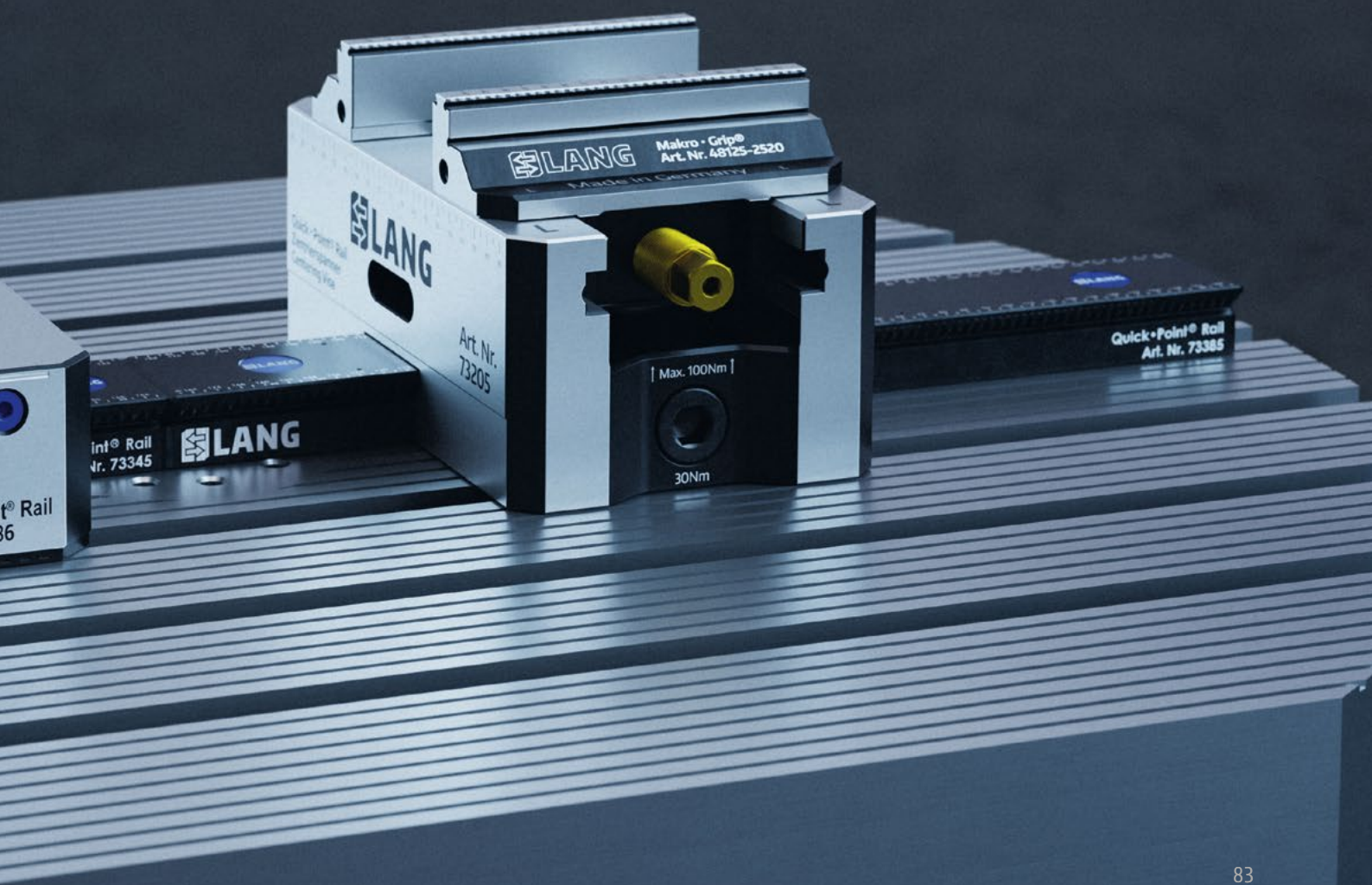



Ready in no time

Get started straight away without prior preparation. Quick-Point® Rail bars can be fitted within two minutes and removed again without leaving any residue. Clamping and extension bars are positioned in the grooves of a machine table or directly on automation pallets.

Cost-efficient and tailored to your needs

Quick-Point® Rail offers a customized solution for your needs. The cost-effectiveness of the quick clamping system is particularly evident on automation pallets and large machine tables, as the quick clamping system does not require zero point base plates.

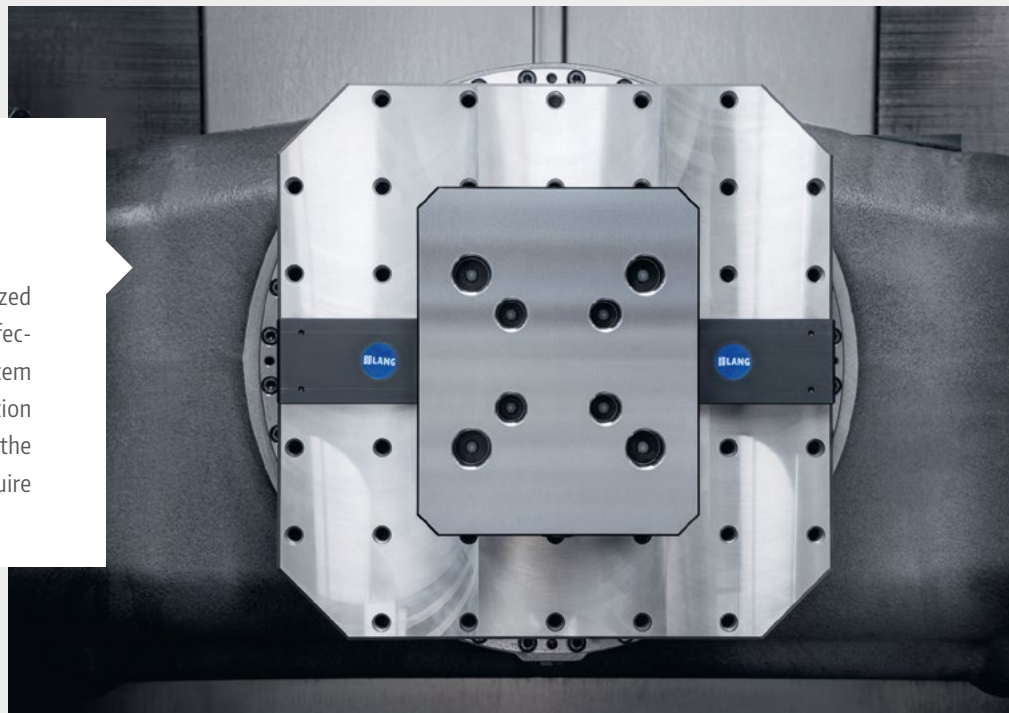

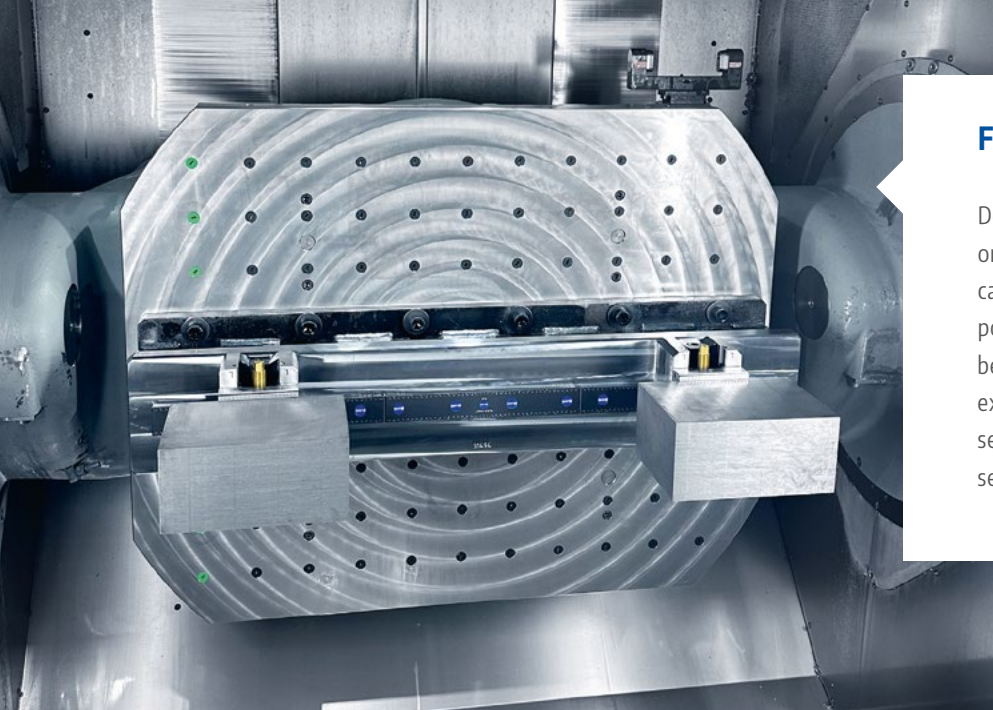

Delmet SA

Flexible expansion

Depending on the size of a machine table or the automation pallet, several bars can be connected together. The starting point is always a clamping bar, which can be supplemented on the left and right by extension bars. The 4 mm pitch of the serration remains consistent even across several connected bars.

Freely moveable

The ability to flexibly adjust the distance between two clamping fixtures is particularly useful when component widths often vary: clamping devices can be easily moved along the serrated clamping and extension bars at 4 mm intervals. There is no better way to ensure optimum positioning.

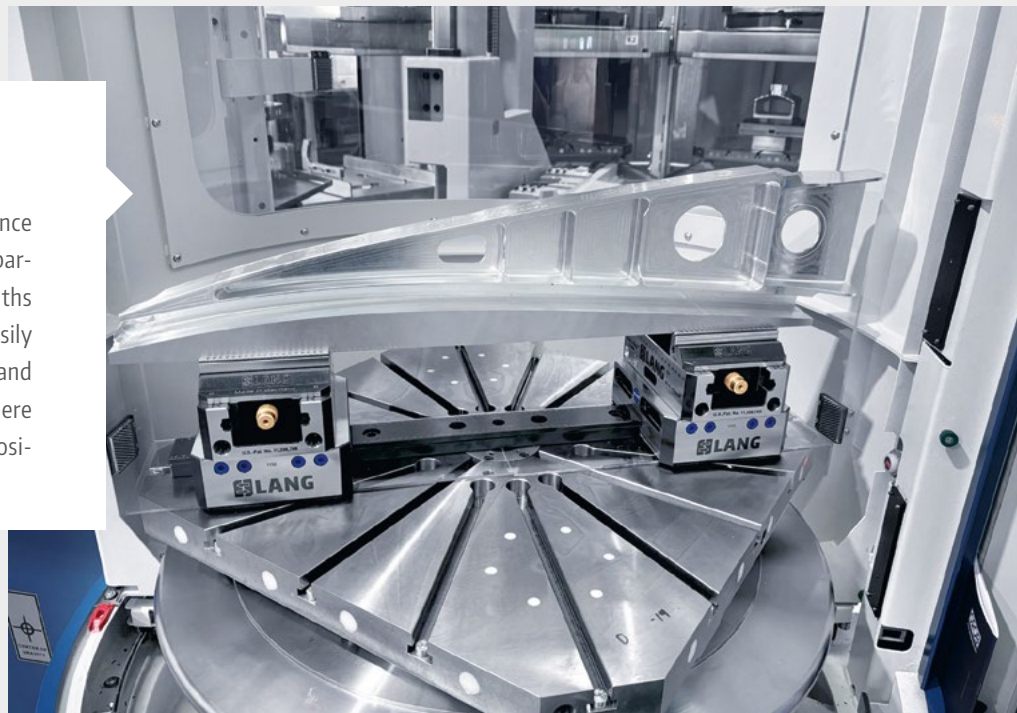

Quick-Point® Rail clamping bars

NEW

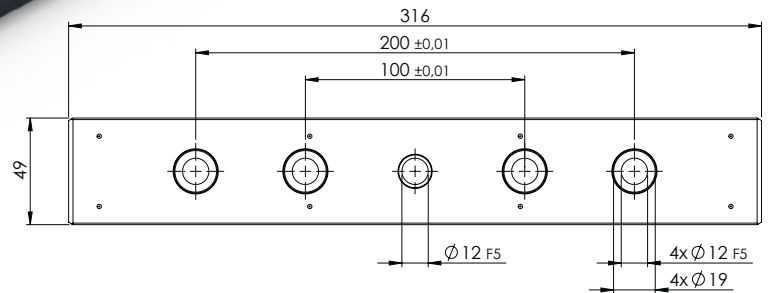
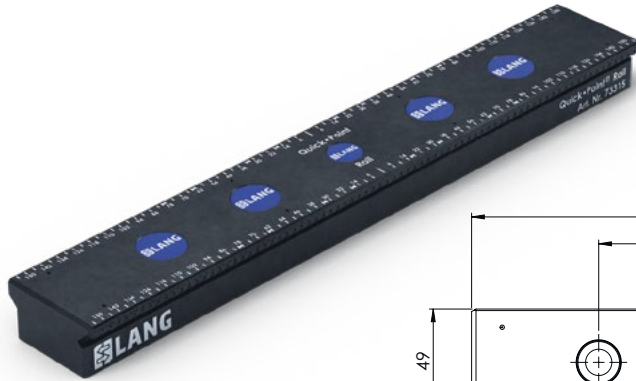

QUICK-POINT® RAIL, CLAMPING BAR WITH MOUNTING BORES

ITEM NO.	DIMENSIONS	MOUNTING BORES	WEIGHT
73315	316 × 49 × 25 mm	4 × for M 10 / M 12 at 50 mm intervals	2.4 kg

This clamping bar is specially designed for the 320 mm pallet size. It can therefore only be used as a single clamping bar and cannot be extended.

NEW

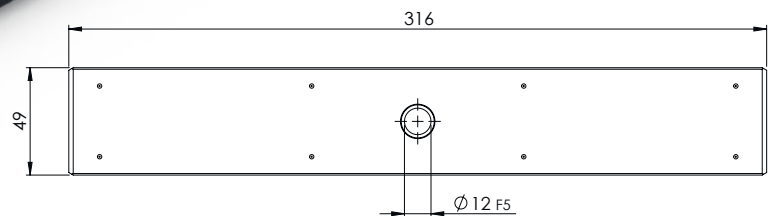

QUICK-POINT® RAIL, CLAMPING BAR WITHOUT MOUNTING BORES

ITEM NO.	DIMENSIONS	WEIGHT
73310	316 × 49 × 25 mm	2.6 kg
45004	Set mounting bores according to customer's request	
45002	Set keyways according to customer's request	

This clamping bar is specially designed for the 320 mm pallet size. It can therefore only be used as a single clamping bar and cannot be extended.

NEW

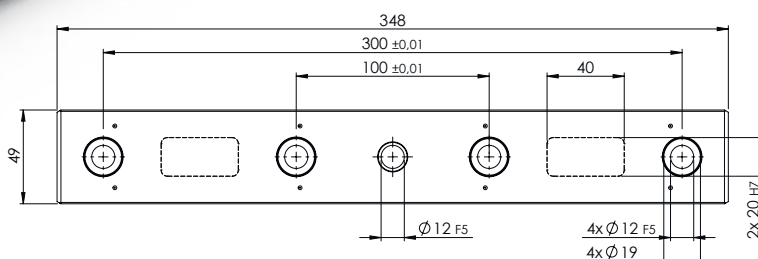
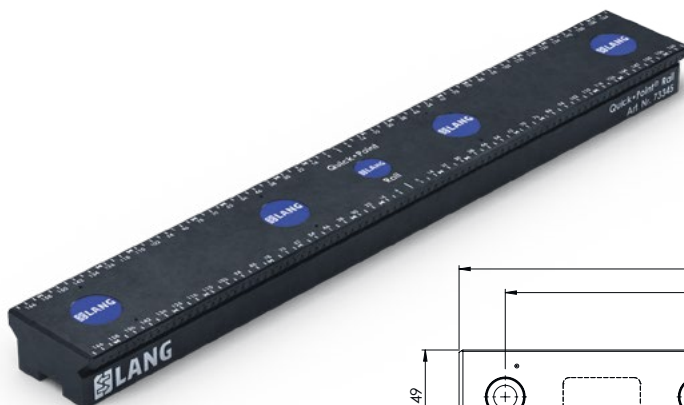

QUICK-POINT® RAIL, CLAMPING BAR WITH MOUNTING BORES

ITEM NO.	DIMENSIONS	MOUNTING BORES	KEYWAYS	WEIGHT
73345	348 × 49 × 25 mm	4 × for M 10 / M 12 at 100 mm intervals	2 × 20H7	2.7 kg

Note: This clamping bar can be extended.

NEW

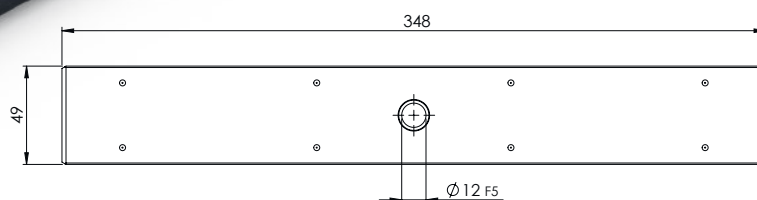
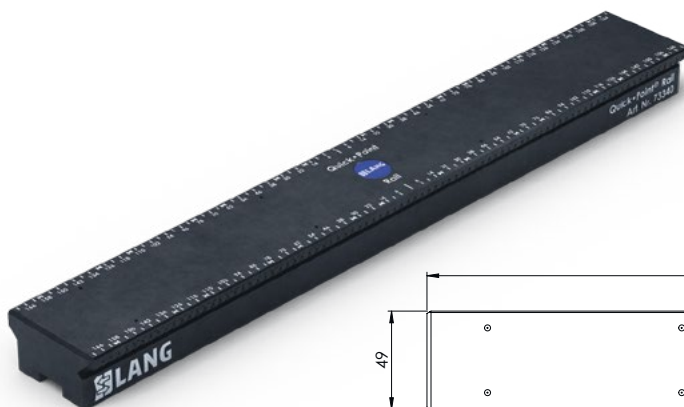

QUICK-POINT® RAIL, CLAMPING BAR WITHOUT MOUNTING BORES

ITEM NO.	DIMENSIONS	WEIGHT
73340	348 × 49 × 25 mm	2.8 kg
45004	Set mounting bores according to customer's request	
45002	Set keyways according to customer's request	

Note: This clamping bar can be extended.

Quick-Point® Rail extension bars



NEW

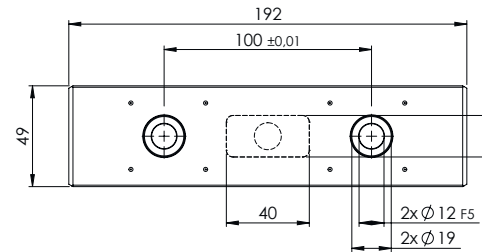

QUICK-POINT® RAIL, EXTENSION BAR WITH MOUNTING BORES

ITEM NO.	DIMENSIONS	MOUNTING BORES	WEIGHT
73195	192 × 49 × 25 mm	2 × for M 10 / M 12 at 100 mm intervals	1.5 kg

This extension bar is to be used exclusively as an addition to the clamping bars (Item No. 73340 / 73345) and can be extended to the left and right as often as required.



NEW



QUICK-POINT® RAIL, EXTENSION BAR WITHOUT MOUNTING BORES

ITEM NO.	DIMENSIONS	WEIGHT
73190	192 × 49 × 25 mm	1.6 kg
45004	Set mounting bores according to customer's request	
45002	Set keyways according to customer's request	

This extension bar is to be used exclusively as an addition to the clamping bars (Item No. 73340 / 73345) and can be extended to the left and right as often as required.

QUICK-POINT® RAIL, CONNECTOR

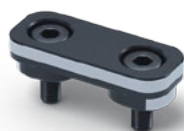

ITEM NO.	QTY
73701	1 pc.

Connectors are needed whenever clamping and extension bars are to be attached to one another.

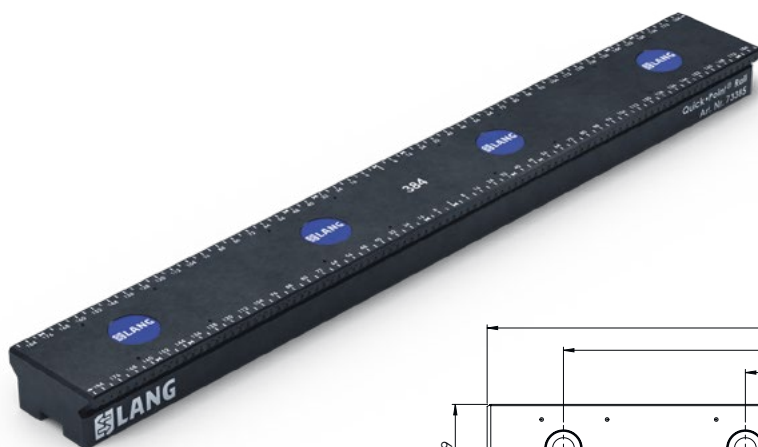

NEW

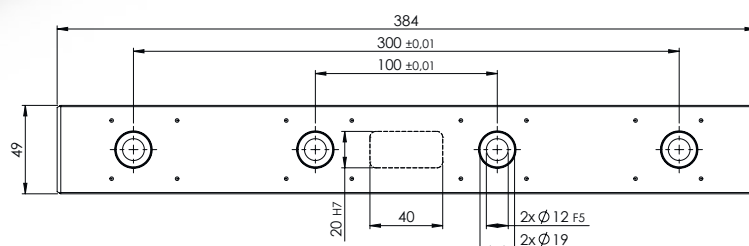

QUICK-POINT® RAIL, EXTENSION BAR WITH MOUNTING BORES

ITEM NO.	DIMENSIONS	MOUNTING BORES	KEYWAYS	WEIGHT
73385	384 × 49 × 25 mm	4 × for M 10 / M 12 at 100 mm intervals	1 × 20H7	2.9 kg

This extension bar is to be used exclusively as an addition to the clamping bars (Item No. 73340 / 73345) and can be extended to the left and right as often as required.

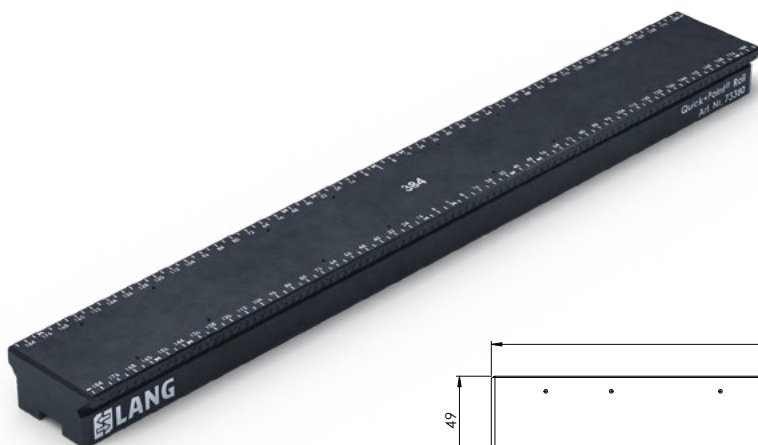

NEW

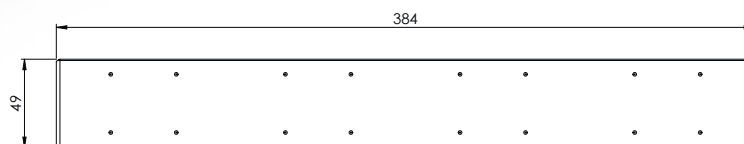

QUICK-POINT® RAIL, EXTENSION BAR WITHOUT MOUNTING BORES

ITEM NO.	DIMENSIONS	WEIGHT
73380	384 × 49 × 25 mm	3.1 kg
45004	Set mounting bores according to customer's request	
45002	Set keyways according to customer's request	

This extension bar is to be used exclusively as an addition to the clamping bars (Item No. 73340 / 73345) and can be extended to the left and right as often as required.

Quick-Point® Rail 5-axis combi risers



NEW

QUICK-POINT® RAIL, 5-AXIS COMBI RISER

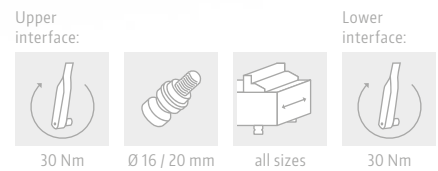

ITEM NO.	DIMENSIONS	WEIGHT
73486	192 × 156 × 60 mm	10.3 kg
73487	192 × 156 × 100 mm	18.3 kg

Optional: Mounting of 4 × Quick-Point® clamping studs Ø 20 mm (Item No. 45570) for mounting in the Quick-Point® 96 system (not included!).

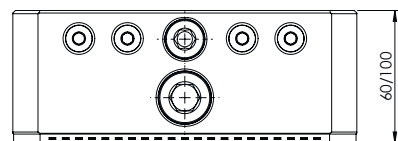
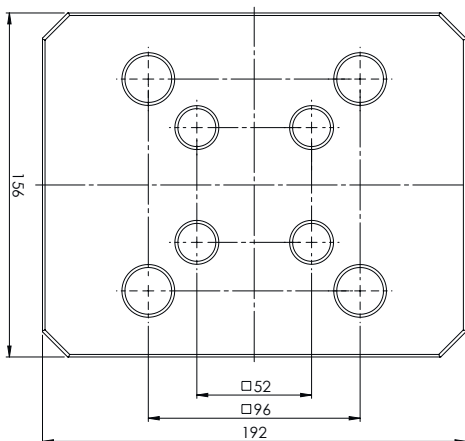

Quick-Point® Rail centering vises

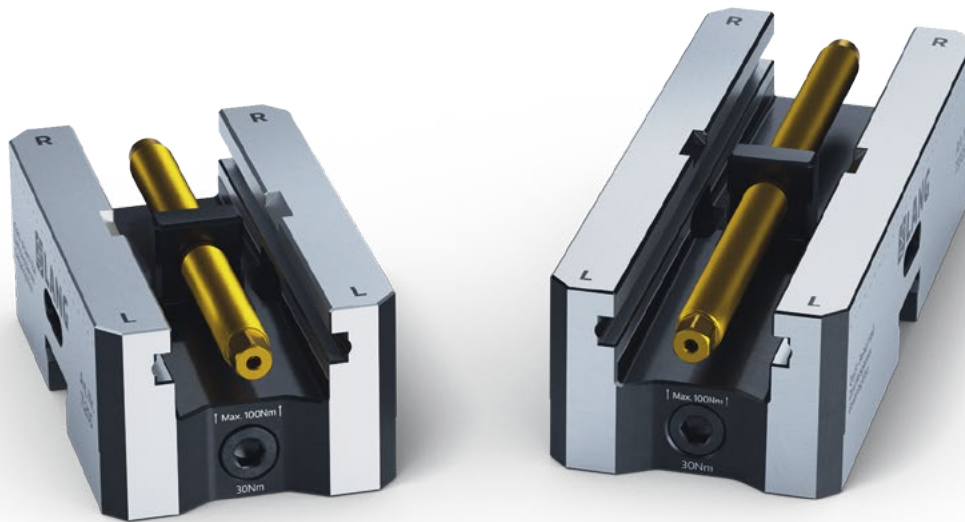

NEW

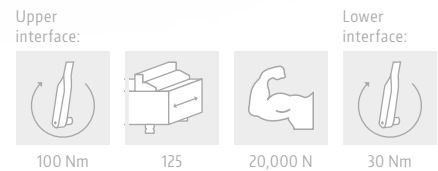

QUICK-POINT® RAIL CENTERING VISE

ITEM NO.	BASE BODY WIDTH	BASE BODY LENGTH	WEIGHT
73205	125 mm	210 mm	11.7 kg
73305	125 mm	310 mm	18.2 kg

Optional: Mounting of 4 × Quick-Point® clamping studs Ø 20 mm (Item No. 45570) for mounting in the Quick-Point® 96 system (not included!).

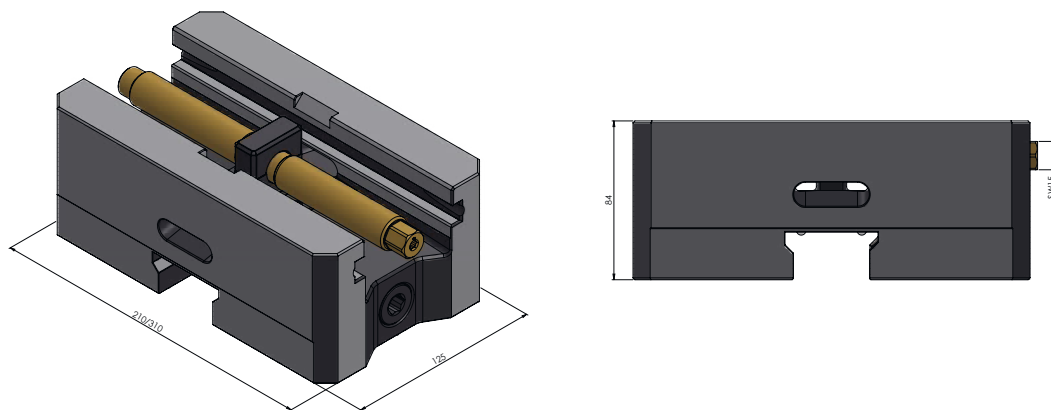

The following jaw variants are suitable and must be ordered in addition to the base body:



Makro-Grip®
48125-2520



Makro-Grip® FS
48125-2520 FS



Makro-Grip®
non-serrated
48125-2522



Makro-4Grip
52515-20
52530-20



Avanti
44251-125



Profilo
49125-125



Vario-Tec
42018-125



WORKHOLDING



- 96** Makro-Grip® stamping technology
- 118** Makro-Grip® 5-axis vise
- 148** Makro-4Grip clamping jaws for round part clamping
- 158** Avanti clamping jaws for contour clamping

- 164** Profilo clamping jaws for contour clamping
- 170** Vario-Tec clamping jaws with support and end stop system
- 174** Vasto-Clamp 6-jaw chuck
- 182** Preci-Point collet chuck
- 188** Makro-Grip® Ultra

Workholding

Workholding systems from LANG Technik are characterized by:

ENORMOUS HOLDING POWER

ACCESSIBILITY

MODULARITY

**MAKRO-GRIP®
TECHNOLOGY**



Makro-Grip®
5-axis vise



Makro-Grip®
stamping technology



Makro-Grip® Ultra

**CLAMPING SYSTEM FOR
LARGE PARTS AND PLATES**

OTHER CLAMPING SOLUTIONS WITH THE (MAKRO-GRIP®) VISE BASE

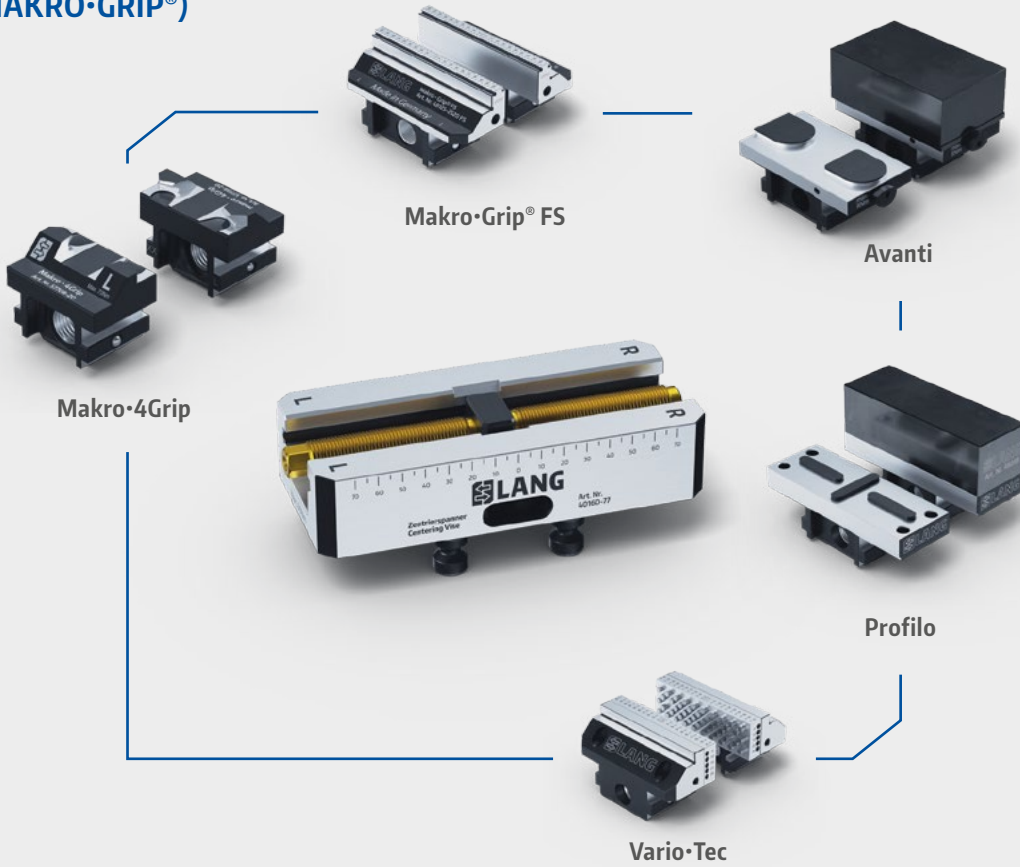

ROUND PART CLAMPING





PATENTED

Makro·Grip®

stamping technology

The stamping technology invented by LANG is the centerpiece of the Makro·Grip® workholding technology and guarantees maximum process reliability in the 5-sided machining of raw parts. Due to its great influence on the actual clamping and machining process, stamping technology is considered today's benchmark in workpiece clamping. During pre-stamping, imprints are made in the raw material under high pressure in order to provide it with a contour. Pre-stamping with a stamping unit takes just 5 seconds per workpiece and does not require any machine capacity – but these five seconds will have a lasting effect on your production and the way you clamp your workpieces.

Primary area of application:

- **Form-fit clamping via holding serration**
- **Cuboid components (optional: round)**
- **1st clamping operation, raw part machining**

Benefits:

- **Highest holding forces and maximum process reliability**
- **Fewer clamping operations thanks to ideal accessibility in 5-sided machining**
- **Distortion- and wear-free clamping even with high-tensile material**

Makro·Grip® stamping technology

“The Original” – Makro·Grip® clamping technology with form-fit

The requirements for a vise in the CNC machining of raw parts are clearly defined. It should hold the workpiece securely and offer as little interfering contour as possible. However, the approach varies greatly in practice. Some vises hold the blank with smooth clamping jaws via a force or friction fit, while others press into the workpiece with their gripping jaws. However, the most efficient clamping

technology is form-fit clamping with pre-stamped blanks. In addition to maximum holding forces, it guarantees absolute process reliability and revolutionized the way workpieces are clamped over 20 years ago. To this day, it is considered the benchmark in 5-sided machining.

Frictional clamping with non-serrated jaws



- **high clamping force** is needed,
- therefore **large and bulky vise** is required.
- **parallelism / flatness** of the workpiece **absolutely necessary**.
- **interfering workpiece** stops for positioning necessary.
- often **limited accessibility**.



Form-fit clamping of pre-stamped blanks with Makro·Grip® serration



- **low clamping force** is sufficient,
- therefore **compact vise**.
- **no wear** on the holding serration and **no distortion** when releasing the clamping.
- **no problem with hard materials**.
- **accurate repeat clamping**.
- permanently **constant clamping quality**.

Clamping with conventional gripping jaws



- **high clamping force** is required, especially for hard materials,
- therefore **large vise** is often required.
- **no defined positioning** during reclamping of the workpiece.
- **wear on the serration**, as it has to bite into **the material**.

The cause and effect of pre-stamping

The pre-stamping of blanks has an enormous impact on the entire manufacturing process. Particularly to be emphasized are the strong holding forces, which influence the milling strategy and also have a clear added value in terms of component quality and offer a high cost-saving potential.

Conventional vises penetrate the workpiece blank with high forces exposing both, the vise and the workpiece to high strains. The Makro-Grip® technology however uses a different approach. By pre-stamping the workpiece blank with up to 20 tons of pressure and preparing it with a defined contour, the forces are already

applied before the actual clamping process. Once it is prepared with the contour (pyramid-shaped truncated indents), the Makro-Grip® 5-axis vise can hold the workpiece by form-fit, absolutely gently and securely with low clamping pressure – always with the same clamping jaws, regardless of the material and the hardness. Due to the low clamping pressure, distortion on the workpiece as well as wear on the vise can virtually be ruled out. Even with high-tensile material an always consistent clamping quality is guaranteed, which is crucial to achieving the desired quality of the machined workpiece.

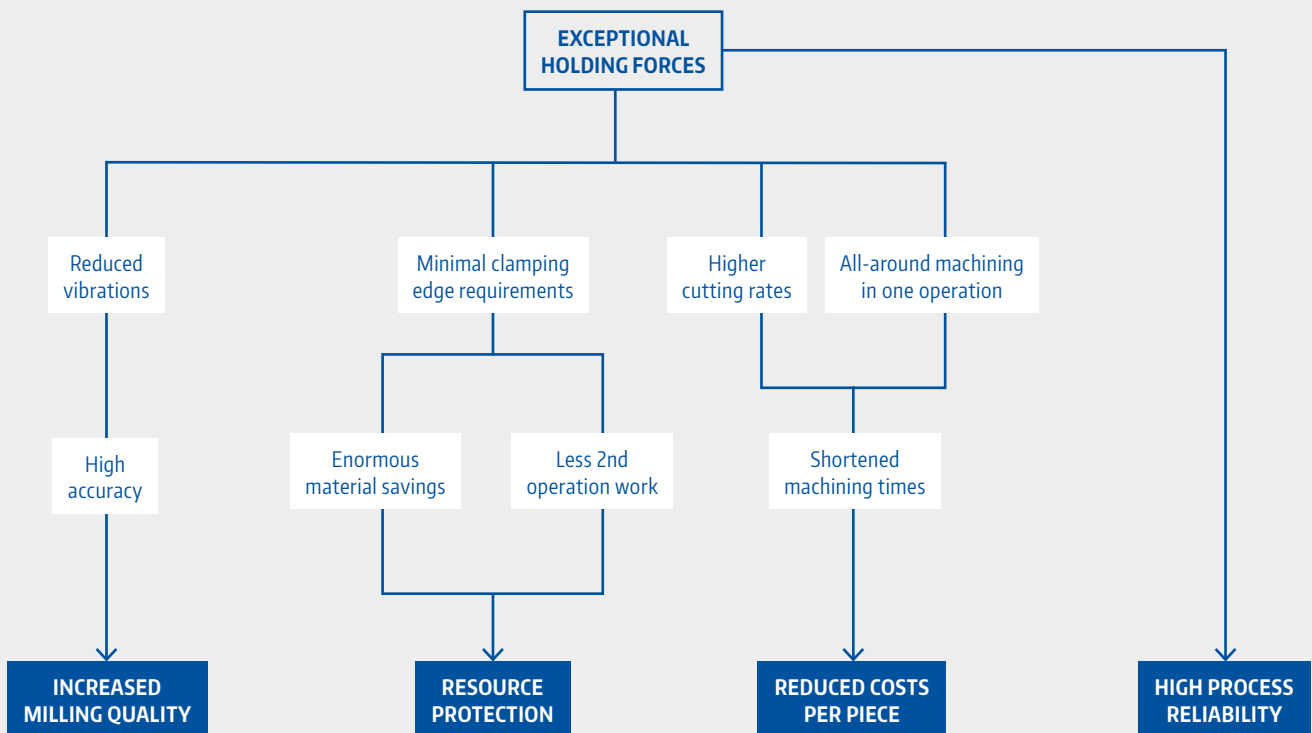

Simply explained: Form-fit through pre-stamping

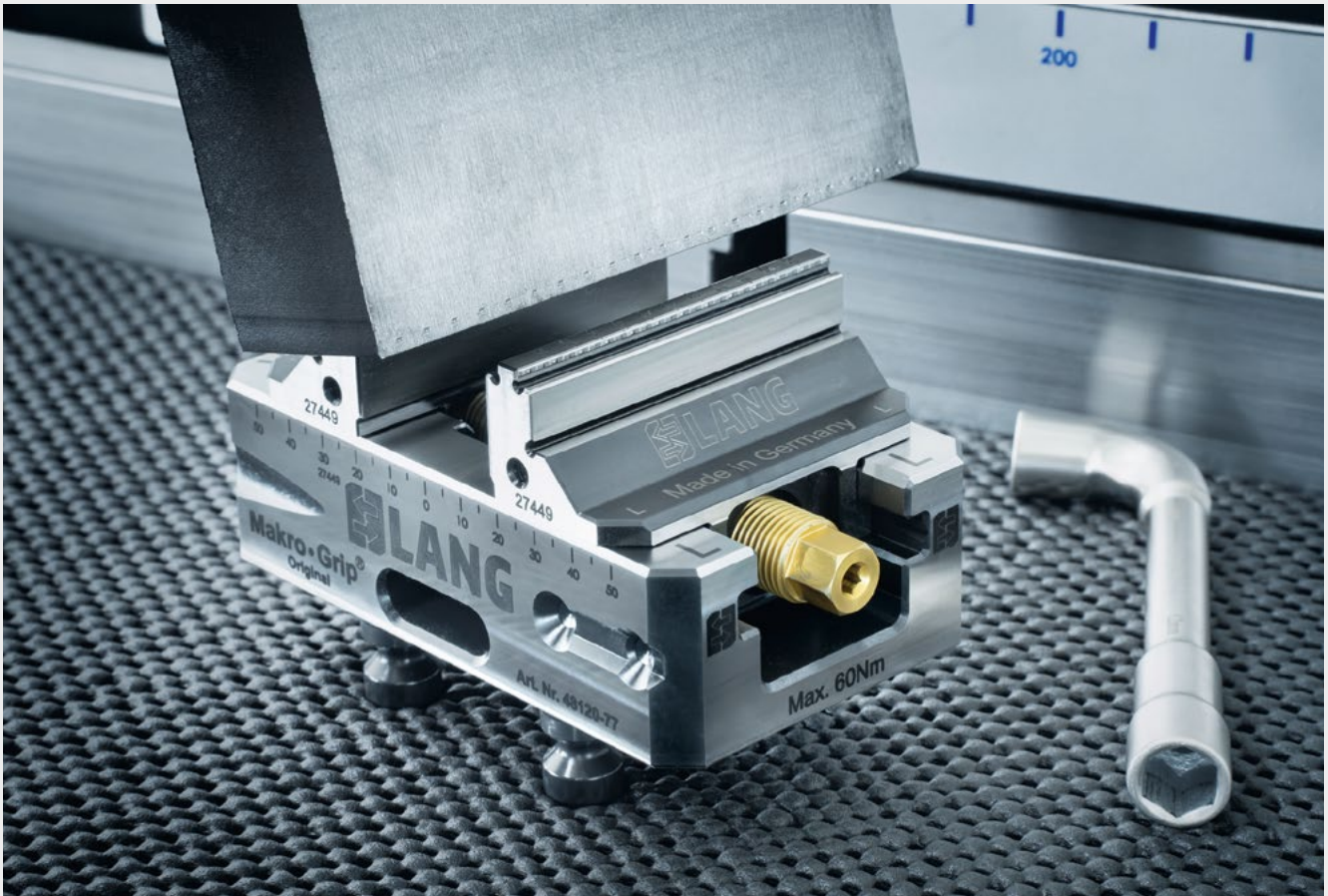

During pre-stamping, the workpiece blank is provided with a defined contour under high pressure. This process takes place at a stamping unit before the actual clamping process. In the clamping

process with a 5-axis vise, the holding serration grips this contour and holds the blank with by form-fit without having to penetrate the material.

Minimal time investment for maximum added value! How to pre-stamp



Significant added value for workpiece clamping can be achieved in just a few steps by pre-stamping a workpiece blank. The pre-stamping process takes less than five seconds and requires no additional machine capacity. The pre-stamping takes place directly on the saw

cut or the oxide layer, without any further preparatory work. The form-fit between the contour in the raw material and the holding serration of the 5-axis vise enables precise positioning without the need for a workpiece end stop.

The space-saving production booster – Where pre-stamping takes place



The options for pre-stamping workpieces are diverse and can be ideally integrated into your work processes and environment. Do you prefer to use your stamping unit flexibly and at different places in your machine shop? Or do you want to position it right next to

your saw or the place where you equip your vises? Suitable solutions are available for both options – either on a mobile stamping trolley or in a stationary version for your workbench.

Which part shapes and materials can be pre-stamped?

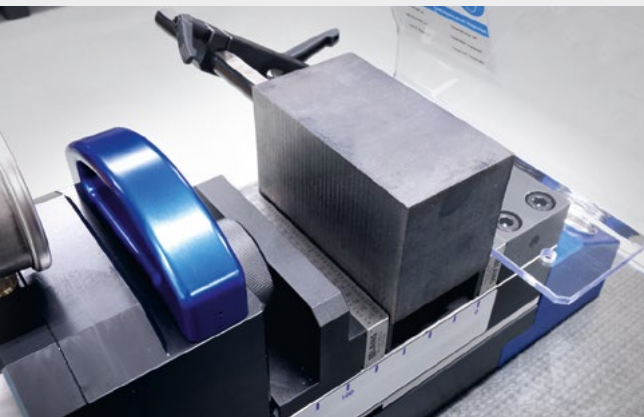

The stamping technology is suitable for both cylindrical and cuboid blanks (two parallel surfaces) and can be used with all non-brittle materials. Excluded are, for example, graphite, composite fiber materials such as carbon, and in some cases cast iron. Hollow and

thin-walled workpieces are only suitable for pre-stamping to a limited extent. If necessary, a test stamping should be conducted at low pressure.

Stamping jaw versions for different materials

Each material is characterized by very specific material properties. Tensile strength and toughness play a particularly important role in pre-stamping. We offer a total of four different stamping jaw versions in order to achieve optimum efficiency in pre-stamping for

every material that can be stamped. These are differentiated by the type of stamping serration and are designed for different material hardnesses.

- The choice of stamping jaws depends on the **tensile strength** and **toughness** of the material.

Effective ranges of the different stamping jaws in terms of tensile strength

The darker the bar, the greater the effective range of the respective stamping jaws.

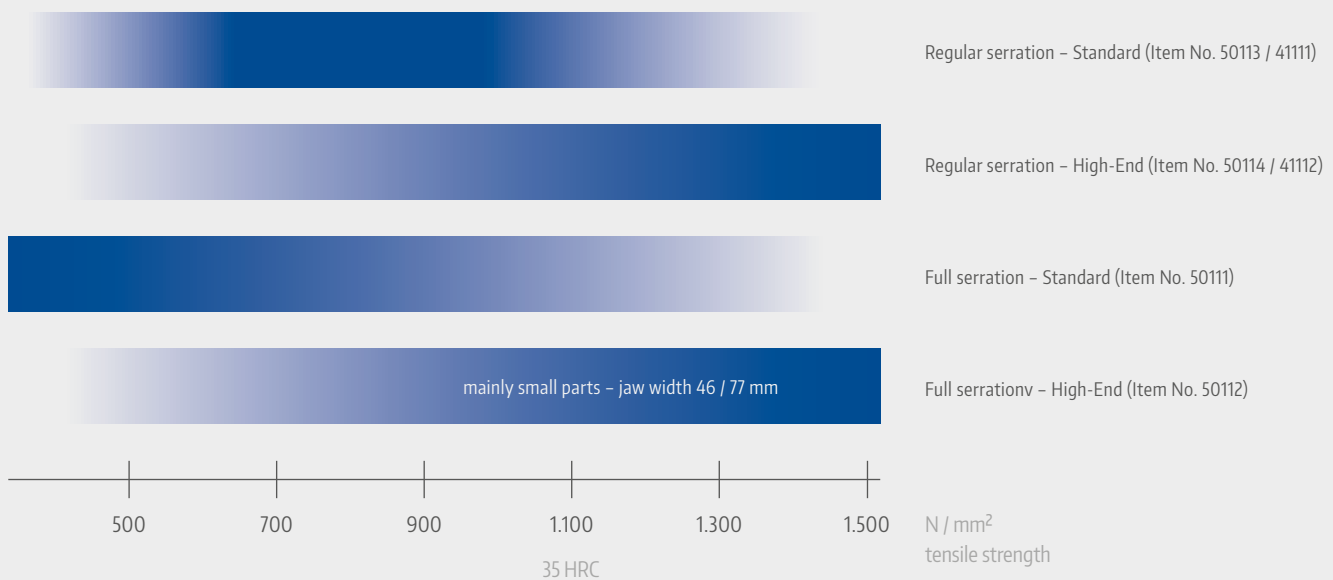

A CLOSER LOOK:

Where Makro·Grip® FS pays off

- for soft materials such as aluminium or materials with high toughness and poor machinability, such as titanium alloys and stainless steels
- for slim workpieces where only a few clamping teeth are engaged
- for high cutting rates in combination with both of the above points

**UP TO 60 % HIGHER
HOLDING FORCES**

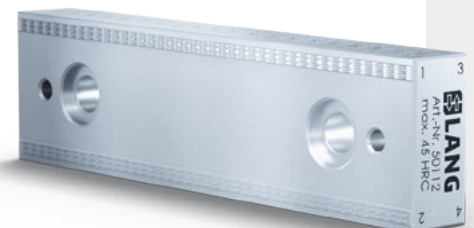

* in the effective area of application.

Makro-Grip® – regular serration



TYPE	MAKRO-GRIP®	
Type of serration	Regular serration	
Tooth-to-tooth distance	6 mm	
Characteristic	Alternating teeth and control marks	
Version	Standard	High-End
Field of application	Universally applicable up to a tensile strength of 1,100 N / mm ²	Ideally suited for all materials over 1,100 N / mm ² that can be stamped

Makro-Grip® FS – full serration

PATENTED

UP TO 60 % HIGHER HOLDING FORCES



TYPE	MAKRO-GRIP® FS	
Type of serration	Continuous / full serration	
Tooth-to-tooth distance	3 mm	
Characteristic	Continuous row of teeth	
Version	Standard	High-End
Field of application	Can be used for soft and tough materials and slim workpieces. Application range up to a tensile strength of 1,100 N / mm ²	Ideally suited for all slim workpieces with a high tensile strength over 1,100 N / mm ²

Correct stamping with Makro·Grip® stamping jaws

**Stamping contour
up to tensile strength 1,100 N / mm²**



The stamping contour with alternating stamping imprints and control marks is clearly visible. The depth of the control marks should be around 0.05 mm. The depth of the stamping imprints is approx. 0.20 mm.

**Stamping contour
from tensile strength 1,100 N / mm²**



For material with a tensile strength of 1,100 N / mm² or more, the control marks should not be visible. The depth of the stamping imprints is approximately 0.10 mm.

Correct stamping with Makro·Grip® FS stamping jaws

**Stamping contour
up to tensile strength 550 N / mm²**



For materials up to approx. 550 N / mm² tensile strength, the control marks may be visible above and below the stamping contour on the material. The depth of the stamping imprints is then approx. 0.3 mm. This applies across the board for all workpiece widths.

**Stamping contour
from tensile strength 550 N / mm²**



From a tensile strength of 550 N / mm², the workpiece width defines whether the control marks are visible. For slim workpieces up to approx. 77 mm, the control marks are still visible, although not as clearly.



With wide workpieces of around 125 mm and a tensile strength of 550 N / mm² or more, the control marks are no longer visible. In this case, we recommend using the stamping depth measuring device to set the correct stamping depth (see page 105).

Setting the stamping pressure correctly

The variety of alloys makes it difficult to make an exact statement about the stamping pressure to be set. In addition to the type of material, the width of the workpiece and the surface texture play an important role. In general, we recommend always starting with

a low stamping pressure and slowly increasing it until the desired stamping depth is reached in the workpiece. It is therefore recommended to carry out a test stamping before each series of stamping jobs.

The right stamping depth



The stamping pressure is set via the pressure control valve on the stamping unit. The following table provides information on the correct stamping depth for different tensile strengths. This is applied to both types of stamping jaws (Makro-Grip® and Makro-Grip® FS).

TENSILE STRENGTH RM	STAMPING DEPTH
up to 550 N / mm ²	approx. 0.3 mm
550 – 1,100 N / mm ²	approx. 0.2 mm
1,100 – 1,400 N / mm ²	approx. 0.1 mm

If the control marks are not visible when pre-stamping with Makro-Grip® FS stamping jaws due to the tensile strength and/or workpiece width, we recommend using the stamping depth measuring device (item no. 50150 or 50152, see page 114)

Benefits of the stamping depth measuring device

- Defined stamping depth
- Increased process reliability
- Minimization of operating errors



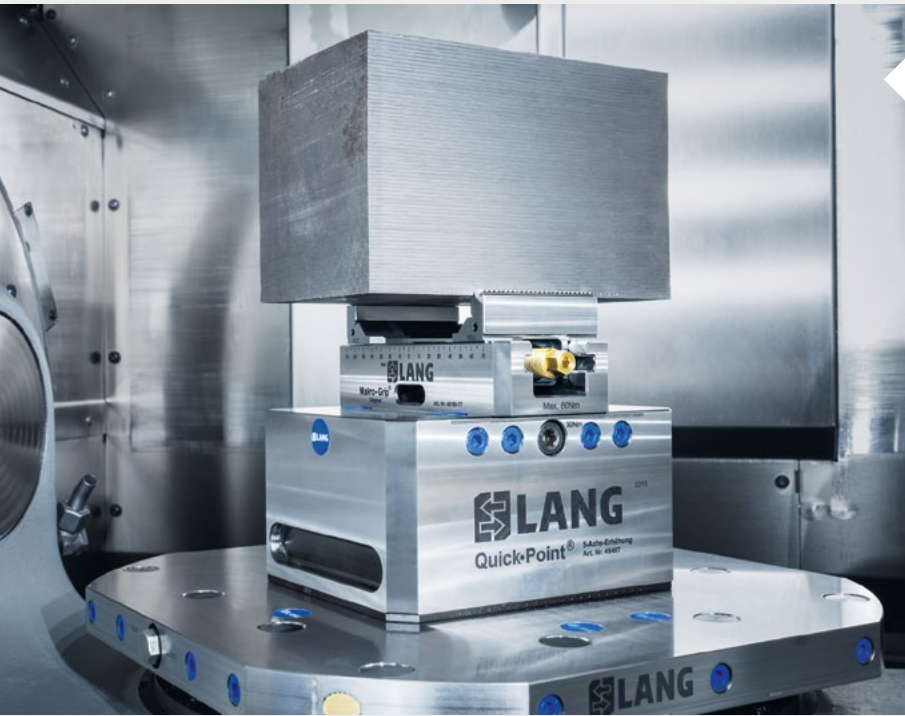

Clamping large workpieces with compact vises

Stamping Technology allows the Makro-Grip® 5-axis vise to clamp workpieces which substantially exceed its volume. Despite a clamping depth of only 3 mm the Makro-Grip® stamping technology guarantees highest process reliability. The compact design in relation to the maximum allowed workpiece size ensures ideal accessibility and thus allows for short tools which results in reduced vibrations and higher cutting rates..

As a guideline, the Makro-Grip® 5-axis vise is able to clamp parts of following size:

Width of workpiece:

3 × jaw width of vise

Height of workpiece:

2 × jaw width of vise

“One and done” – finishing parts in one operation

The form-fit between clamping jaw serration and stamping contour makes it possible to safely pick up the workpiece at its smallest cross-section and clamp it edgewise with ideal accessibility. This strategy allows a lot of parts to be finished in one operation. For automated, lights-out machining it means that complete batches can be produced without the presence of an operator.

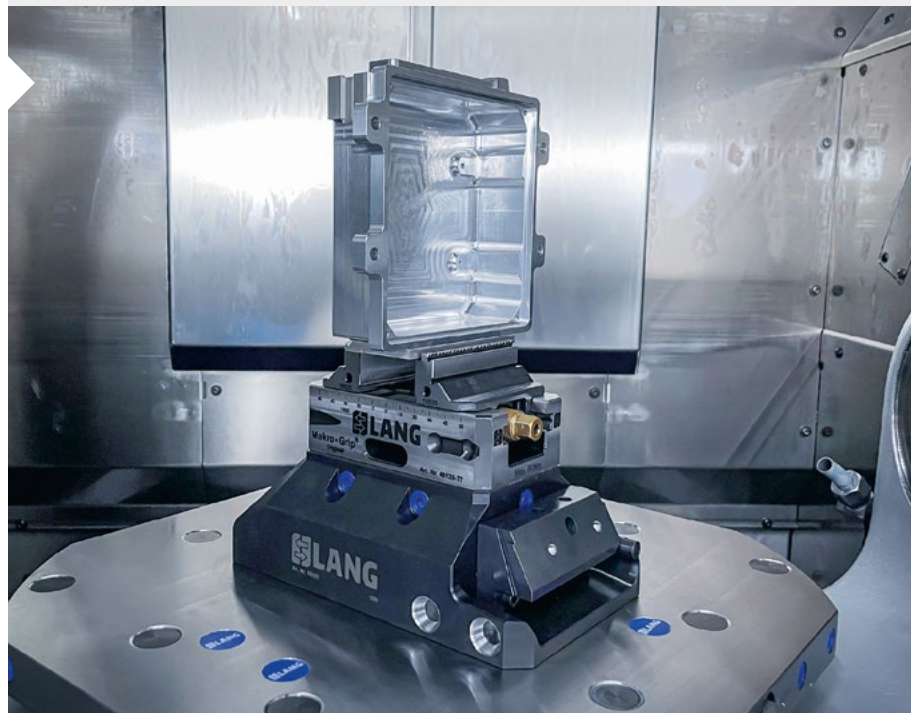

Precicut Zerspanungstechnik GmbH & Co. KG



Material of the pre-stamped and clamped component: 1.2714 QT

Wear-free clamping of high-strength material

Since the workpiece is pre-stamped outside of the machine, there is almost no wear on the clamping device or the clamping jaws. The form-fit clamping technology ensures the necessary process reliability, even when machining high-strength materials. Even tough materials that are difficult to machine, such as titanium and stainless steel, can be easily pre-stamped and reliably held in the Makro-Grip® 5-axis vise, without any wear on the gripping jaws, thus guaranteeing consistent clamping quality long-term.

Minimal clamping depth saves material costs

The form-fit clamping with the Makro-Grip® stamping technology makes it possible to hold even large workpieces with a minimal clamping edge of only 3 mm in a safe and reliable manner. This not only means fewer chips during the second operation and thus faster production processes, but also saves resources. In particular, when machining high-alloy steels and high-quality aluminium, enormous raw material cost savings can be achieved this way.

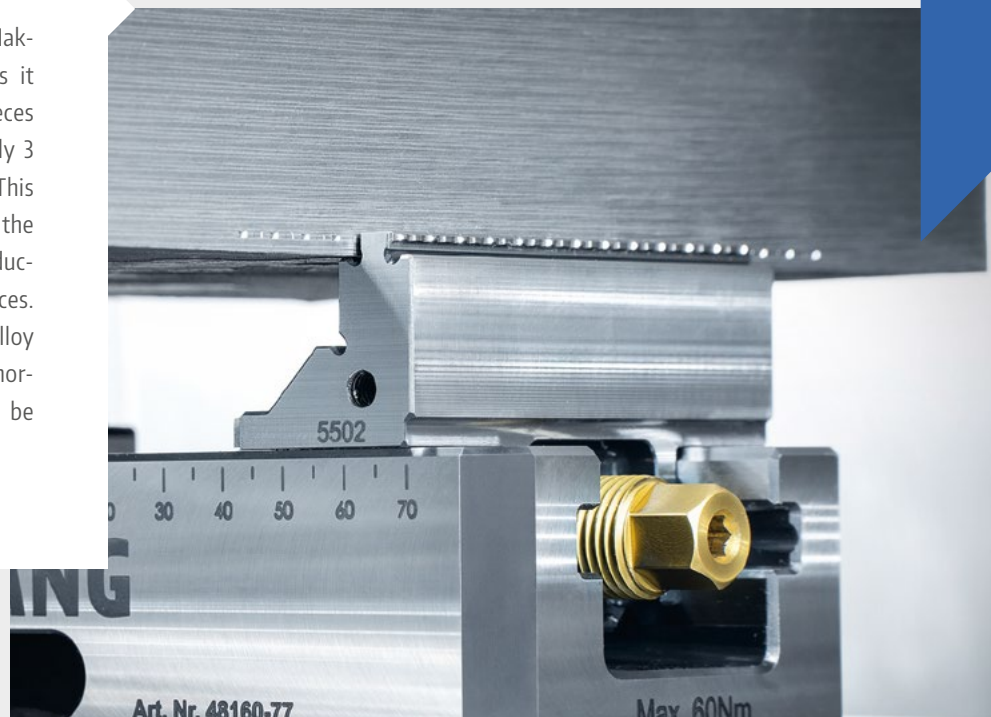

Makro·Grip®

Stamping Unit:

- stamping unit base in two different lengths
- stamping range 260 mm or 410 mm
- quick adjustment of the stamping range
- pneumatic foot or hand switch for triggering the stamping process
- scaled workpiece end stop
- pressure control valve for adjusting the stamping pressure
- quick-connect coupling system on the hydraulic housing
- makrolon protection shield
- pneumatic-hydraulic power multiplier (up to 360 bar)
- optional accessories such as: center marking tool, centering device, stamping depth measuring device

Additional features of the stamping trolley:

- mobile workshop trolley for flexible use at any location
- drawer for storing tools and accessories
- plastic tray with generous space
- option to retrofit a grooved plate
- available in three different versions
 - without grooved plate and a short stamping base
 - with grooved plate and a long stamping base
 - with grooved plate and two long stamping bases





ZERO POINT CLAMPING

WORKHOLDING

Schubhöhe
Schubhöhe
mit 300 kg
Druckkraft
Stärke / Stamping depth
ca. / approx. 0.1 mm
ca. / approx. 0.2 mm
ca. / approx. 0.3 mm

Zero-Point-System
Prägetechnik mit präziser
und bewährter Präzision
Zugfestigkeit / Tensile strength (N) Maßstab / Stamping depth
100 kg / 2000 N ca. / approx. 0.1 mm
200 kg / 4000 N ca. / approx. 0.2 mm
300 kg / 6000 N ca. / approx. 0.3 mm

LANG

Makro•Grip®
Prägetechnik | Stamping Technology
The Original - Made in Germany

Makro-Grip® stamping units

 PLEASE NOTE: STAMPING JAWS MUST NOW BE ORDERED SEPARATELY.



MAKRO-GRIP® STAMPING UNIT FOR WORKBENCHES

ITEM NO.	TYPE	MAX. STAMPING RANGE	WEIGHT
52610	Standard	260 mm	73 kg
54110	Extended	410 mm	83 kg

Includes: Stamping vise, pneumatic-hydraulic power multiplier (1 - 360 bar), foot pedal, protection shield, scaled workpiece end stop

Suitable stamping jaws:



Makro-Grip® Standard, regular serration for materials up to 35 HRC
Item No. 50113



Makro-Grip® High-End, regular serration for materials up to 45 HRC
Item No. 50114



Makro-Grip® FS Standard, full serration for materials up to 35 HRC
Item No. 50111



Makro-Grip® FS High-End, full serration for materials up to 45 HRC
Item No. 50112



Makro-4Grip stamping jaws for round blanks for materials up to 45 HRC
Item No. 51111



LANG recommends:

Conversion set for existing stamping units

Simply retrofit an existing stamping unit (Item No. 41...) and benefit from the latest upgrades to the stamping unit.

- No more reconditioning of your stamping jaw serration
- Increased user-friendliness thanks to new accessories

More information on page 117.



New stamping jaws with four serrated rows

4 times longer service life without reconditioning of stamping jaws.



MAKRO-GRIP® STAMPING JAWS WITH REGULAR SERRATION

ITEM NO.	TYPE	FOR MATERIALS	QTY
50113	Standard	up to 35 HRC	1 pair
50114	High-End	up to 45 HRC	1 pair

Includes: Set of 3 mm parallels

- Universally applicable for all materials up to approximately 1,400 N / mm² that can be pre-stamped



MAKRO-GRIP® FS STAMPING JAWS WITH CONTINUOUS / FULL SERRATION

ITEM NO.	TYPE	FOR MATERIALS	QTY
50111	Standard	up to 35 HRC	1 pair
50112	High-End	up to 45 HRC	1 pair

Includes: Set of 3 mm parallels

- for soft materials such as aluminium or materials with high toughness and poor machinability, such as titanium alloys and stainless steels
- for slim workpieces where only a few clamping teeth are engaged
- for high cutting rates in combination with both of the above points

Makro·Grip® stamping trolley

 PLEASE NOTE: STAMPING JAWS MUST NOW BE ORDERED SEPARATELY.



STAMPING TROLLEY WITH MAKRO·GRIP® STAMPING UNIT

ITEM NO.	TYPE	MAX. STAMPING RANGE	STAMPING VISES	GROOVED PLATE
52611	Standard	260 mm	1	no
54112	Extended	410 mm	1	yes
54122	Extended	2 × 410 mm	2	yes

Includes: Trolley with stamping vise, pneumatic-hydraulic power multiplier (1 - 360 bar), foot pedal, protection shield, scaled workpiece end stop.
Depending on the version: Second stamping vise, second protection shield, grooved plate

Suitable stamping jaws:



Makro·Grip® Standard, regular serration for materials up to 35 HRC
Item No. 50113



Makro·Grip® High-End, regular serration for materials up to 45 HRC
Item No. 50114



Makro·Grip® FS Standard, full serration for materials up to 35 HRC
Item No. 50111



Makro·Grip® FS High-End, full serration for materials up to 45 HRC
Item No. 50112



Makro-4Grip stamping jaws for round blanks for materials up to 45 HRC
Item No. 51111



ADDITIONAL STAMPING VISE FOR DUAL STAMPING

ITEM NO.	TYPE	MAX. STAMPING RANGE	WEIGHT
52613	Standard	260 mm	29 kg
54113	Extended	410 mm	36 kg

Includes: Mounting and connecting material



MAKRO-GRIP® STAMPING UNIT SPACERS

ITEM NO.	LENGTHS	QTY
53020	12 / 28 / 68 / 260 mm	1 set

Utilization of stamping unit spacers

Stamping unit spacers are used to quickly and precisely set the exact distance between two stamping vises on a grooved plate. They are inserted into the t-slot and placed between the two base bodies. By

using different lengths, common distances of the Quick-Point® zero point clamping system can be simulated: 52 mm, 104 mm, 192 mm and 384 mm.

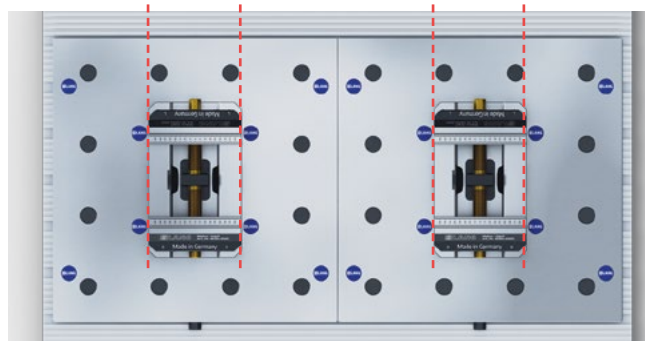
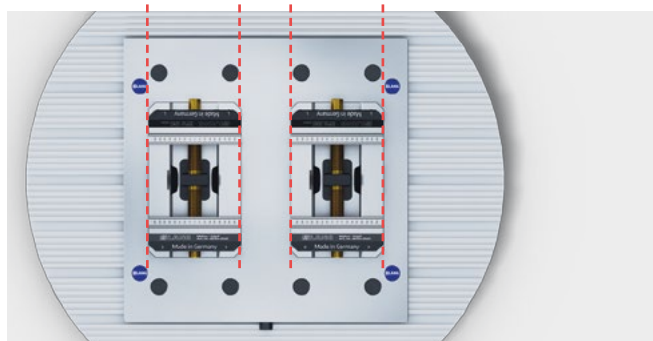

Accessories for Makro·Grip® stamping units

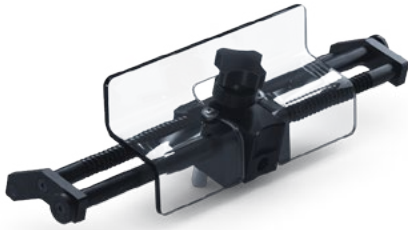

CENTERING DEVICE FOR MAKRO·GRIP® STAMPING UNIT

ITEM NO.	MAX. WORKPIECE WIDTH	QTY
50151	205 mm	1 pc.

Automatic, centered positioning of the blank (up to workpiece width 205 mm) without prior measuring or setting of a workpiece endstop.



DEPTH GAUGE FOR MAKRO·GRIP® STAMPING UNIT

ITEM NO.	QTY
50152	1 pc.

Convenient setting of the correct input pressure by reading off the correct stamping depth on a dial gauge without additional visual inspection.



CENTERING DEVICE & DEPTH GAUGE SET FOR MAKRO·GRIP® STAMPING UNIT

ITEM NO.	MAX. WORKPIECE WIDTH	QTY
50150	205 mm	1 set

The new accessory set of centering device and depth gauge saves time during setup and reduces the likelihood of operator application errors.

Center marking tool

The center marking tool plunges a notch above the stamping contour at the center of the part. This marking allows the exact and centric positioning of parts in Makro·Grip® 5-axis vises without any end stops.



CENTER MARKING TOOL

ITEM NO.	DESCRIPTION
41010	Center marking tool
41010-01	Spare marking stud

The center marking tool will be mounted to the moveable jaw of the stamping unit with two M 6 × 14 screws (included).



Gauging blocks for measuring wear of stamping jaws

Creating trust! Always the same clamping quality. To ensure consistent holding power in the clamping device, it is necessary to check the wear of the stamping teeth regularly.



MAKRO-GRIP® GAUGING BLOCKS

ITEM NO.	SUITABLE FOR STAMPING JAWS	QTY
41020	Item No. 50113 / 50114 and 41111 / 41112	1 set



MAKRO-GRIP® FS GAUGING BLOCKS

ITEM NO.	SUITABLE FOR STAMPING JAWS	QTY
50153	Item No. 50111 / 50112	1 set

Utilization of gauging blocks

The checking procedure is identical for both variants. First, the two gauging blocks are positioned with the recesses at the outer ends of the stamping jaws and clamped. It is important to ensure that the stamping teeth are placed in the recesses. If the measuring

block now fits centrally between the stamping teeth, the service life of the serration has been exceeded. The stamping jaws should be turned (new stamping jaw versions – Item No. 51111 – 51114) or sent in for reconditioning (for stamping jaws with Item No. 41111 / 41112).



Accessories for previous Makro-Grip® stamping units

Stamping jaws



MAKRO-GRIP® STAMPING JAWS WITH REGULAR SERRATION

ITEM NO.	TYPE	FOR MATERIALS	QTY
41111	Standard	up to 35 HRC	1 pair

Includes: Set of 3 mm parallels



MAKRO-GRIP® STAMPING JAWS WITH REGULAR SERRATION

ITEM NO.	TYPE	FOR MATERIALS	QTY
41112	High-End	up to 45 HRC	1 pair

Includes: Set of 3 mm parallels

Reconditioning of serration



Left: Stamping jaw with original thickness of 18 mm.
Right: Reconditioned stamping jaw with a thickness of 15 mm.

RECONDITIONING OF STAMPING JAWS

ITEM NO.	DESCRIPTION
41111-01	Standard stamping jaws
41112-01	High-End stamping jaws

When the stamping teeth are worn out the jaws can be reconditioned up to 6 times per pair. The original thickness of a stamping jaw is 18 mm. With every reconditioning process the thickness is reduced by 0.5 mm until it has reached 15 mm (measured at the highest stamping tooth tip). If a stamping tooth is broken off more than the regular 0.5 mm per reconditioning is required. The total amount of possible reconditioning processes is reduced accordingly.

Note for dual stamping: With every reconditioning process we generally supply shims. The thickness of these shims is determined by the remaining thickness of the stamping jaw. Thickness of stamping jaw and shim will always amount to 18 mm. This guarantees that stamping jaws which have been reconditioned at different intervals can be used together, applying the same pressure on the workpiece

LANG recommends:

In order to bridge the time of the reconditioning process we suggest keeping a second pair of stamping jaws in reserve!



Conversion set for existing stamping units

Would you like to equip your existing stamping unit with the new 4-way serrated stamping jaws or improve the handling of your stamping unit with new accessory options? Then this conversion set offers a cost-effective way to upgrade your stamping unit. This set consists of a fixed and a movable carrier jaw, to which the new stamping jaws are attached. It is compatible with all stamping units that begin with Item No. 41...

- No more reconditioning of your stamping jaw serration
- Increased user-friendliness thanks to new accessories



STAMPING UNIT CONVERSION SET

ITEM NO.	FOR	QTY
51260-20	all Makro-Grip® stamping units starting with Item No. 41...	1 pair

The conversion set (consisting of a fixed and movable carrier jaw) can be used to mount new Makro-Grip® stamping jaws, as well as the centering device and stamping depth measuring device, on existing stamping units. Note: Stamping jaws are not included in the scope of delivery!



New 4-way serrated stamping jaws on existing stamping units.



Mounted centering device and stamping depth measuring device on existing stamping unit.

Still available for previous stamping units:



- Center marking tool (page 114)
- Gauging blocks (page 115)





PATENTED

Makro·Grip®

5-axis vise

The Makro·Grip® 5-axis vise is the perfect clamping device for 5-sided machining of raw parts. Thanks to its compact design and the low clamping depth of the workpieces, it offers particularly good accessibility and at the same time enables high material savings. Thanks to its form-fit clamping technology, the Makro·Grip® offers the highest holding forces and therefore maximum safety. Despite great holding forces, only low clamping forces are required, which enables distortion-free, secure, and gentle clamping. This has a positive effect on the workpiece quality and the durability of the clamping device.

Primary area of application:

- **Form-fit clamping via holding serration**
- **Cuboid components**
- **1st clamping operation, raw part machining**

Benefits:

- **Highest holding forces and maximum process reliability**
- **Fewer clamping operations thanks to ideal accessibility in 5-sided machining**
- **Distortion and wear-free clamping**

Makro-Grip®

Clamping jaws:

- reversible jaws milled from solid material
- Makro-Grip® clamping technology (form-fit clamping)
- with holding serration on both sides
- 3 mm clamping depth (can be adjusted for raw material with radius)
- minimal interfering contours
- additional clamping options for smooth clamping

Base body:

- made of robust, case-hardened steel
- compact, handy design and low weight
- TIN-coated threaded spindle in encapsulated center piece
- low tightening torque for gentle, distortion-free clamping
- integrated zero point interface
- equipped with automation interface
- fully compatible with the clamping jaw types for 2nd clamping operation
- can be used as a single- or multi-clamping vise
- centering accuracy ± 0.02 mm



ZERO POINT CLAMPING

WORKHOLDING

Zentrierspanner
Centering Vice

LANG

LANG
Metro-Grip®
Art. No. 66074-T20

50 40 30 20 10 0

0120-77

Different versions of the 5-axis vise

Makro-Grip® 5-axis vise 46



Makro-Grip® Micro

Jaw width: 46 mm
Base width: 46 mm
Base length: 77 mm



Jaw width: 46 mm
Base width: 77 mm
Base length: 77 mm

Makro-Grip® 5-axis vise 77



Jaw width: 46 mm
Base width: 77 mm
Base lengths: 102 / 130 mm



Jaw width: 77 mm
Base width: 77 mm
Base lengths:
102 / 130 / 170 / 210 mm



Makro-Grip® Night King

Jaw width: 77 mm
Base width: 77 mm
Base length: 130 mm

Makro-Grip® 5-axis vise 125



Jaw width: 77 mm
Base width: 125 mm
Base lengths: 160 / 210 mm

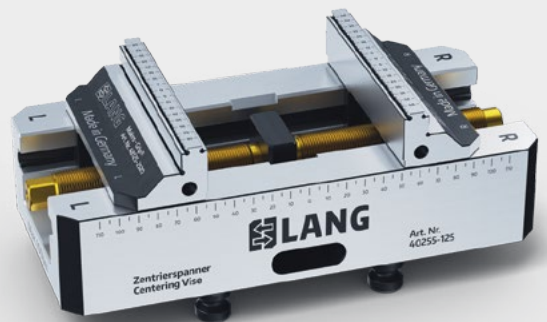

Jaw width: 125 mm
Base width: 125 mm
Base lengths:
160 / 210 / 260 / 310 / 360 mm

The benefits of pre-stamping on the clamping process

The external pre-stamping of the workpiece relieves the 5-axis vise. While conventional machining vises with serration have to work double duty (1. indent the material, 2. hold the workpiece), the function of the Makro-Grip® 5-axis vise

is limited to only holding the workpiece. The compact build of the Makro-Grip® 5-axis vise is possible due to the requirement of much lower clamping forces. The resulting advantages are shown below.

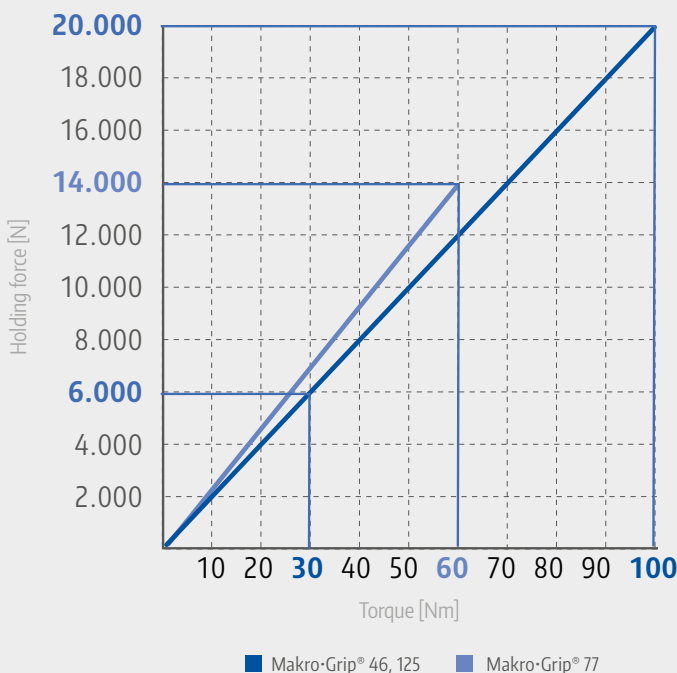
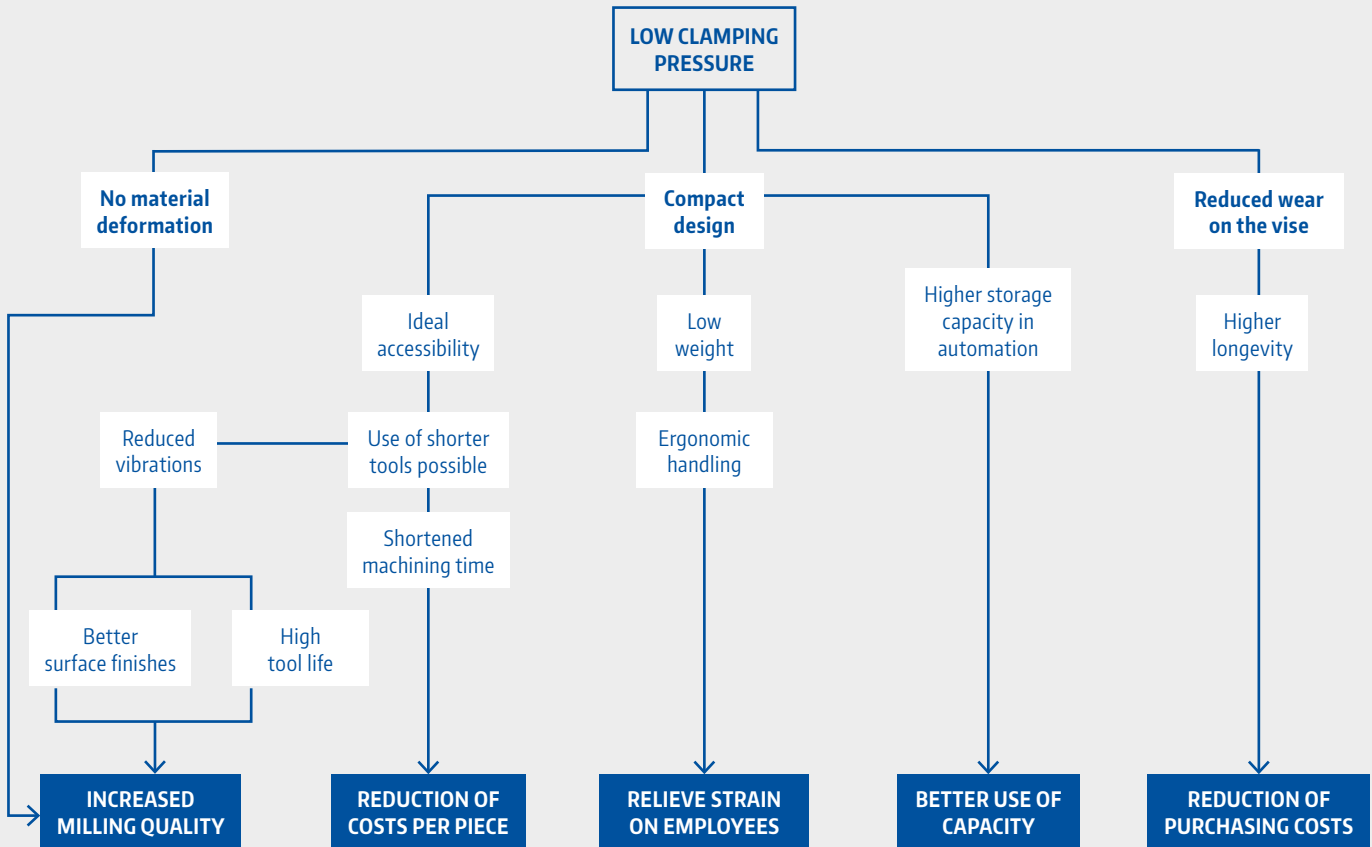

Clamping pressure / holding force ratio

Thanks to the form-fit clamping technology, workpieces can be securely clamped with low clamping pressure. Deformation and distortion of the material while clamping and releasing is impossible! This diagram highlights the relation between the actuation torque and the resulting holding forces with our three vise sizes – 46 mm, 77 mm and 125 mm.

Makro·Grip® 46 Micro, 5-axis vise jaw width 46 mm



MAKRO·GRIP® 46 MICRO, 5-AXIS VISE JAW WIDTH 46 MM

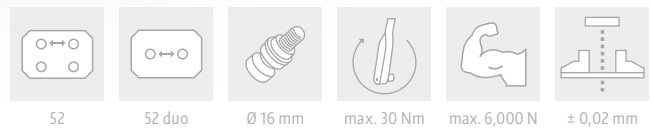

ITEM NO.	BASE BODY LENGTH	CLAMPING RANGE	WEIGHT	CONSISTS OF:
48040-46 *	77 mm	0 - 65 mm	0.8 kg	40040-46 + 48046-4620

The Makro·Grip® 46 Micro is equipped with two Ø 16 mm clamping studs on its underside for clamping in the Quick·Point® Duo zero point clamping system.

* Suitable for use in the RoboTrex Compact automation system.

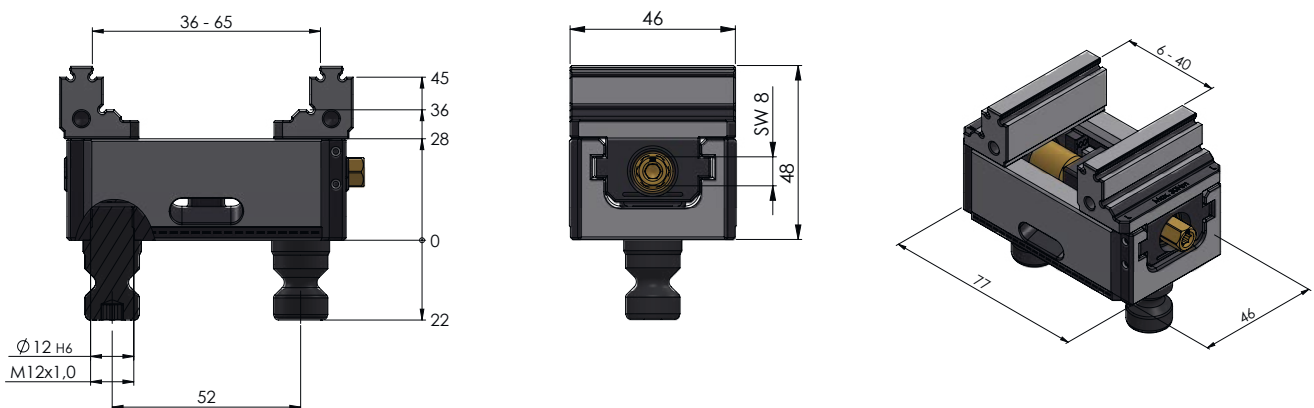

Suitable jaw variants:

Avanti:	44461	Spare jaws:	48046-4620
		Spare jaws with FS serration:	48046-4620 FS
		Non-serrated spare jaws:	48046-4622

Makro·Grip® 46, 5-axis vise jaw width 46 mm



MAKRO-GRIP® 46, 5-AXIS VISE JAW WIDTH 46 MM



ITEM NO.	BASE BODY LENGTH	CLAMPING RANGE	WEIGHT	CONSISTS OF:
48065-46	77 mm	0 – 65 mm	1.8 kg	40065-46 + 48046-4620

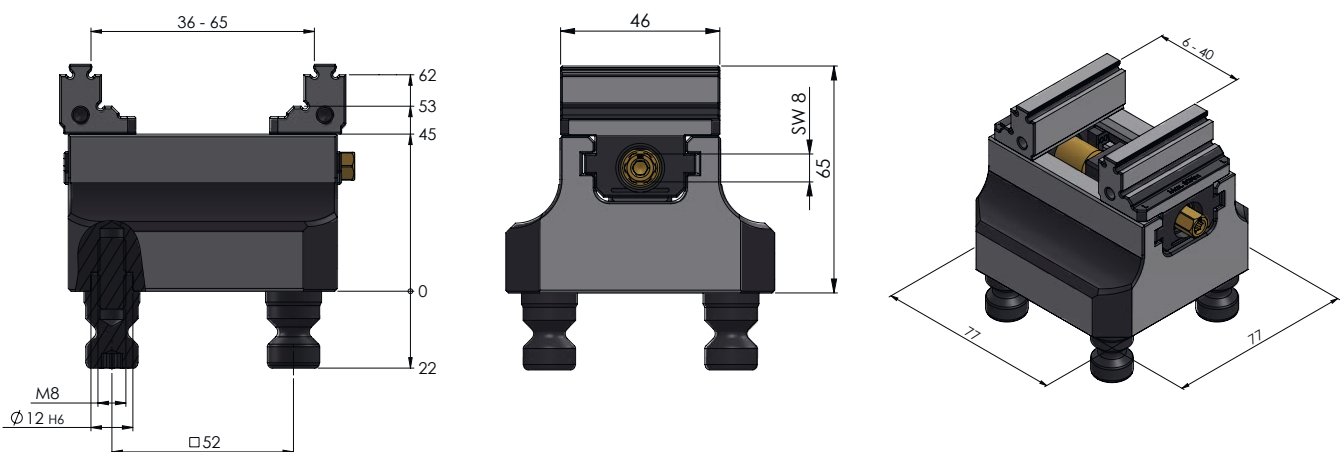

Suitable jaw variants:

Avanti: **44461**

Spare jaws: **48046-4620**
 Spare jaws with FS serration: **48046-4620 FS**
 Non-serrated spare jaws: **48046-4622**

Makro-Grip® 77, 5-axis vise jaw width 46 mm



MAKRO-GRIP® 77, 5-AXIS VISE JAW WIDTH 46 MM



ITEM NO.	BASE BODY LENGTH	CLAMPING RANGE	WEIGHT	CONSISTS OF: **
48085-46	102 mm	0 – 85 mm	2.1 kg	40085-46 + 48085-4620
48120-46 *	130 mm	0 – 120 mm	2.6 kg	40120-46 + 48077-4620

* Suitable for use in the RoboTrex and RoboTrex Compact automation systems.

** The base of the vise is engraved with the individual part number and no longer with the item number of the entire assembly.

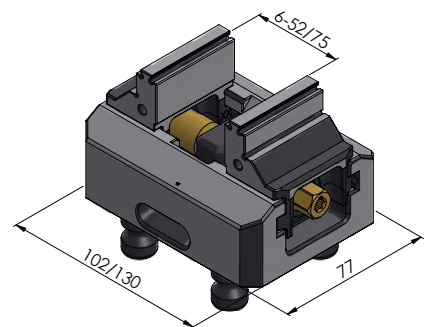
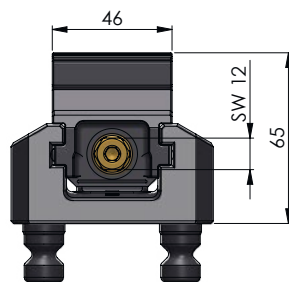
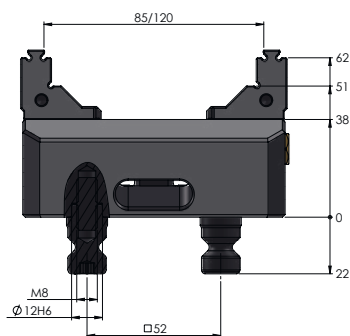

Suitable jaw variants:

Makro-4Grip: 57708-20 / 57711-20
 Avanti: 44771-46 / 44771-77
 Profilo: 49077
 Vario-Tec: 42018-77

Spare jaws: 48085-4620 / 48077-4620
 Spare jaws with FS serration: 48085-4620 FS / 48077-4620 FS
 Non-serrated spare jaws: 48085-4622 / 48077-4622

Due to the identical size of the jaw guide, these three variants can also be used with a jaw width of 77 mm.

Makro·Grip® 77, 5-axis vise jaw width 77 mm

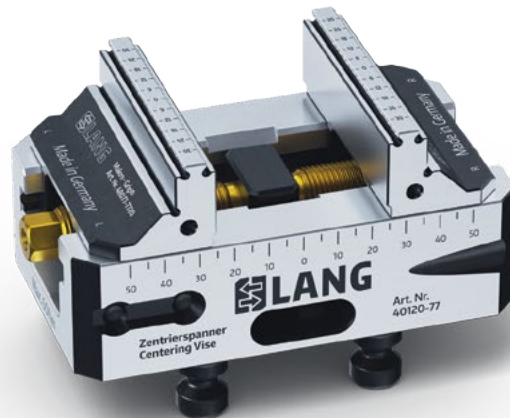

MAKRO-GRIP® 77, 5-AXIS VISE JAW WIDTH 77 MM



ITEM NO.	BASE BODY LENGTH	CLAMPING RANGE	WEIGHT	CONSISTS OF: **
48085-77	102 mm	0 – 85 mm	2.4 kg	40085-77 + 48085-7720
48120-77 *	130 mm	0 – 120 mm	2.9 kg	40120-77 + 48077-7720
48160-77	170 mm	0 – 160 mm	3.6 kg	40160-77 + 48077-7720
48200-77	210 mm	0 – 200 mm	4.2 kg	40200-77 + 48077-7720

* Suitable for use in the RoboTrex and RoboTrex Compact automation systems.

** The base of the vise is engraved with the individual part number and no longer with the item number of the entire assembly.

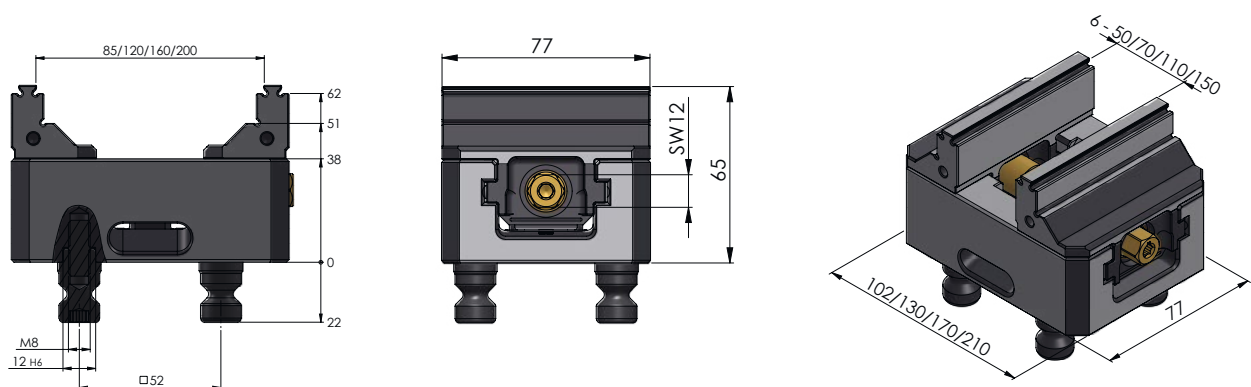

Suitable jaw variants:

Makro-4Grip: **57708-20 | 57711-20**
 Avanti: **44771-46 | 44771-77**
 Profilo: **49077**
 Vario-Tec: **42018-77**

Spare jaws: **48085-7720 | 48077-7720**
 Spare jaws with FS serration: **48085-7720 FS | 48077-7720 FS**
 Non-serrated spare jaws: **48085-7722 | 48077-7722**

Due to the identical size of the jaw guide, these three variants can also be used with a jaw width of 46 mm.

Makro·Grip® 125, 5-axis vise jaw width 77 mm



MAKRO·GRIP® 125, 5-AXIS VISE JAW WIDTH 77 MM



ITEM NO.	BASE BODY LENGTH	CLAMPING RANGE	WEIGHT	CONSISTS OF: **
48155-77	160 mm	0 – 155 mm	7.4 kg	40155-77 + 48125-7720
48205-77 *	210 mm	0 – 205 mm	9.1 kg	40205-77 + 48125-7720

* Suitable for use in the RoboTrex96 automation system.

** The base of the vise is engraved with the individual part number and no longer with the item number of the entire assembly.

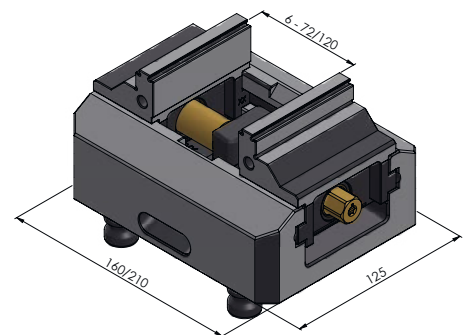
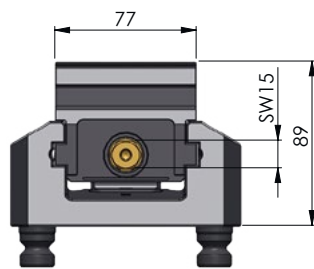
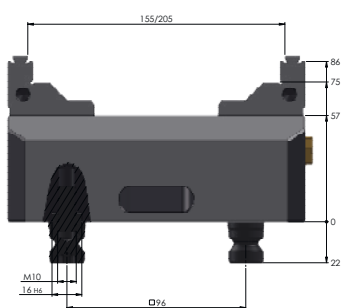

Suitable jaw variants:

Makro·4Grip: 52515-20 / 52530-20
 Avanti: 44251-125
 Profilo: 49125
 Vario·Tec: 42018-125

Spare jaws: 48125-7720
 Spare jaws with FS serration: 48125-7720 FS
 Non-serrated spare jaws: 48125-7722

Due to the identical size of the jaw guide, these three variants can also be used with a jaw width of 125 mm.

Makro·Grip® 125, 5-axis vise jaw width 125 mm

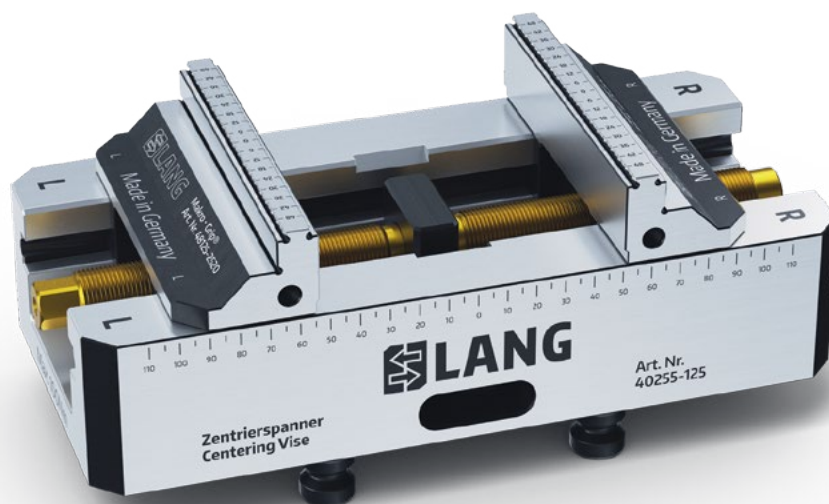

MAKRO-GRIP® 125, 5-AXIS VISE JAW WIDTH 125 MM



ITEM NO.	BASE BODY LENGTH	CLAMPING RANGE	WEIGHT	CONSISTS OF: **
48155-125	160 mm	0 - 155 mm	8.3 kg	40155-125 + 48125-2520
48205-125 *	210 mm	0 - 205 mm	10.1 kg	40205-125 + 48125-2520
48255-125	260 mm	0 - 255 mm	12.0 kg	40255-125 + 48125-2520
48305-125	310 mm	0 - 305 mm	13.9 kg	40305-125 + 48125-2520
48355-125	360 mm	0 - 355 mm	15.7 kg	40355-125 + 48125-2520

* Suitable for use in the RoboTrex96 automation system.

** The base of the vise is engraved with the individual part number and no longer with the item number of the entire assembly.

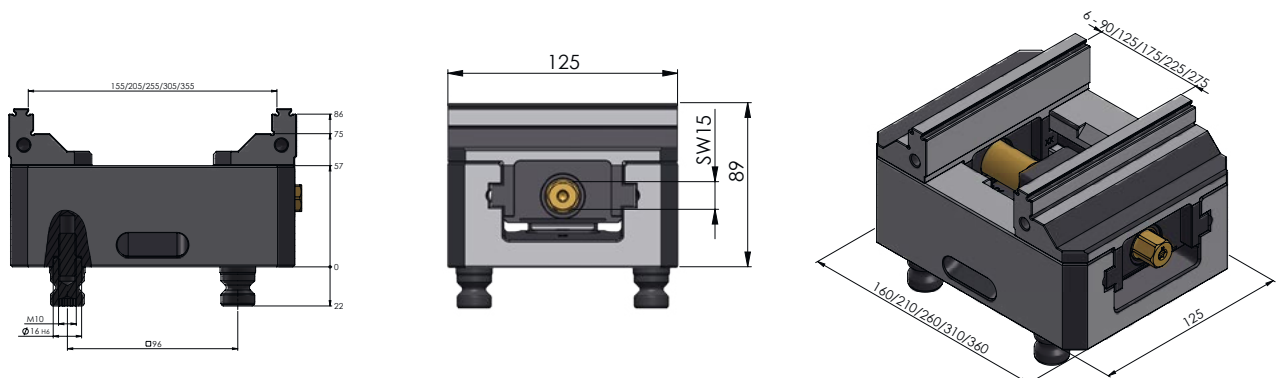

Suitable jaw variants:

Makro-4Grip: **52515-20 / 52530-20**
 Avanti: **44251-125**
 Profilo: **49125**
 Vario-Tec: **42018-125**

Spare jaws: **48125-2520**
 Spare jaws with FS serration: **48125-2520 FS**
 Non-serrated spare jaws: **48125-2522**

Due to the identical size of the jaw guide, these three variants can also be used with a jaw width of 77 mm.

Makro-Grip® 5-axis vise

Spare Parts



SPARE SPINDLE + CENTER PIECE MAKRO-GRIP® 46

ITEM NO.	FOR	SPINDLE LENGTH	WEIGHT
4846082	48040-46 / 48065-46	82 mm	0.1 kg

Threaded spindle with low-wear TIN coating with internal hexagon (size 4) and external hexagon (size 8).



SPARE SPINDLE + CENTER PIECE MAKRO-GRIP® 77

ITEM NO.	FOR	SPINDLE LENGTH	WEIGHT
4877100	48085-46 / 48085-77	100 mm	0.2 kg
4877135	48120-46 / 48120-77	135 mm	0.3 kg
4877175	48160-77	175 mm	0.3 kg
4877215	48200-77	215 mm	0.4 kg

Threaded spindle with low-wear TIN coating with internal hexagon (size 5) and external hexagon (size 12).

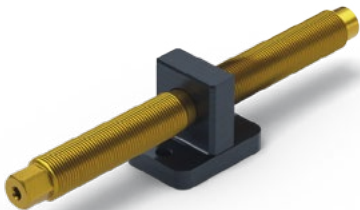

SPARE SPINDLE + CENTER PIECE MAKRO-GRIP® 125

ITEM NO.	FOR	SPINDLE LENGTH	WEIGHT
4825164	48155-77 / 48155-125	164 mm	0.6 kg
4825214	48205-77 / 48205-125	214 mm	0.7 kg
4825264	48255-125	264 mm	0.8 kg
4825314	48305-125	314 mm	0.9 kg
4825364	48355-125	364 mm	1.0 kg

Threaded spindle with low-wear TIN coating with internal hexagon (size 5) and external hexagon (size 15).

Makro·Grip® 5-axis vise Accessories



WRENCH FOR MAKRO·GRIP® 5-AXIS VISE

ITEM NO.	FOR	VICE SIZE	WRENCH SIZE
45510	External Hexagon	46	SW 8
45500	External Hexagon	77	SW 12
45501	External Hexagon	125	SW 15
45515	Internal Hexagon	46	SW 4
45505	Internal Hexagon	77 / 125	SW 5

Wrenches for pre-adjusting the clamping range, initial clamping setting (external hexagon) and reversing the clamping jaws (internal hexagon).



HEXAGON SOCKET

ITEM NO.	SQUARE DRIVE	VICE SIZE	WRENCH SIZE
45507	3/8"	46	8 mm
45508	3/8"	77	12 mm
45509	3/8"	125	15 mm

Hexagon Socket (DIN 3120) for a consistent and safe clamping process.



CORDLESS DRILL ATTACHMENT

ITEM NO.	FOR	SIZE
47005	Internal Hexagon	5 mm

The cordless drill attachment is used to achieve centering accuracy of the jaws easier when exchanging them, especially with longer vise bases. You will also speed-up the exchange or reversal of jaws by using the cordless drill attachment.

Service



TUNGSTEN-CARBIDE-COATING FOR MAKRO·GRIP® JAWS

ITEM NO.	JAW WIDTH	QTY
45046-17	46 mm	per pair
45077-17	77 mm	per pair
45125-17	125 mm	per pair

A special Tungsten-Carbide-Coating can be applied on the jaws' planar surfaces in order to intensify the friction when clamping non-stamped workpieces.

Makro-Grip® 77 contour jaws

The latest generation of Makro-Grip® contour jaws offers convincing ease of use. The contour jaws are attached without changing the Makro-Grip® clamping jaws and without tools, which guarantees a pleasant setup process in seconds. In the process, the contour jaws snap into the Makro-Grip® serration with their stamping contour and hold them in position. Magnets finally pull the contour jaws towards the clamping jaws and ensure a firm fit.

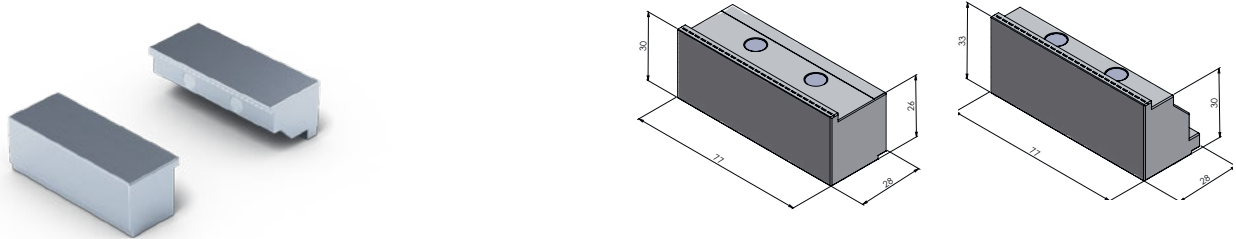

CONTOUR JAWS, ALUMINIUM FOR MAKRO-GRIP® 5-AXIS VISE 77

ITEM NO.	JAW WIDTH	FOR	WEIGHT	QTY
48409-77	77 mm	Inner side	0.3 kg	1 pair
48419-77	77 mm	Outer side	0.3 kg	1 pair

FOR MAKRO-GRIP®	48409-77	48419-77
	CLAMPING RANGE:	
48085-46 *	-	60 mm
48120-46 *	50 mm	100 mm
48085-77	-	60 mm
48120-77	50 mm	100 mm
48160-77	90 mm	140 mm
48200-77	130 mm	180 mm

* Contour jaws can be used if narrowed from 77 mm to 46 mm.



Makro·Grip® 125 contour jaws

LANG recommends:

These contour jaws can be particularly useful in automated production with RoboTrex. Using them makes it possible to finish parts in the second operation with Makro·Grip® 5-axis vises, without having to switch to other clamping devices.

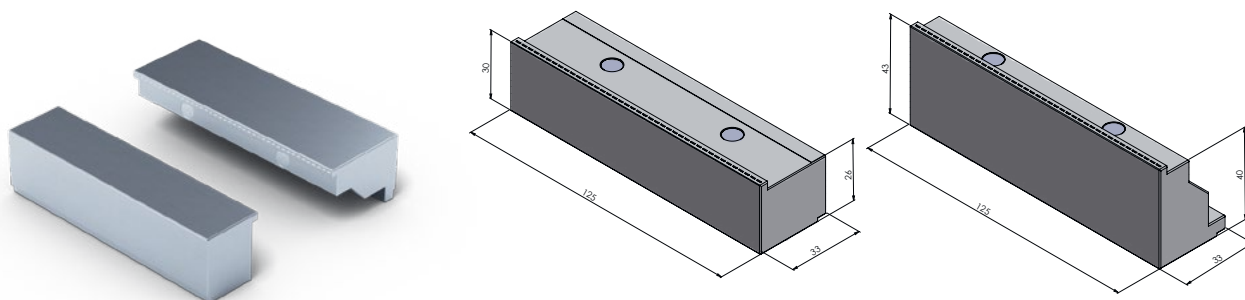

CONTOUR JAWS, ALUMINIUM FOR MAKRO·GRIP® 5-AXIS VISE 125

ITEM NO.	JAW WIDTH	FOR	WEIGHT	QTY
48409-125	125 mm	Inner side	0.6 kg	1 pair
48419-125	125 mm	Outer side	0.6 kg	1 pair

FOR MAKRO·GRIP®	48409-125	48419-125
	CLAMPING RANGE:	
48155-77 *	40 mm	120 mm
48205-77 *	90 mm	170 mm
48155-125	40 mm	120 mm
48205-125	90 mm	170 mm
48255-125	140 mm	220 mm
48305-125	190 mm	270 mm
48355-125	240 mm	320 mm

* Contour jaws can be used if narrowed from 125 mm to 77 mm.



One vise for all component shapes and machining steps

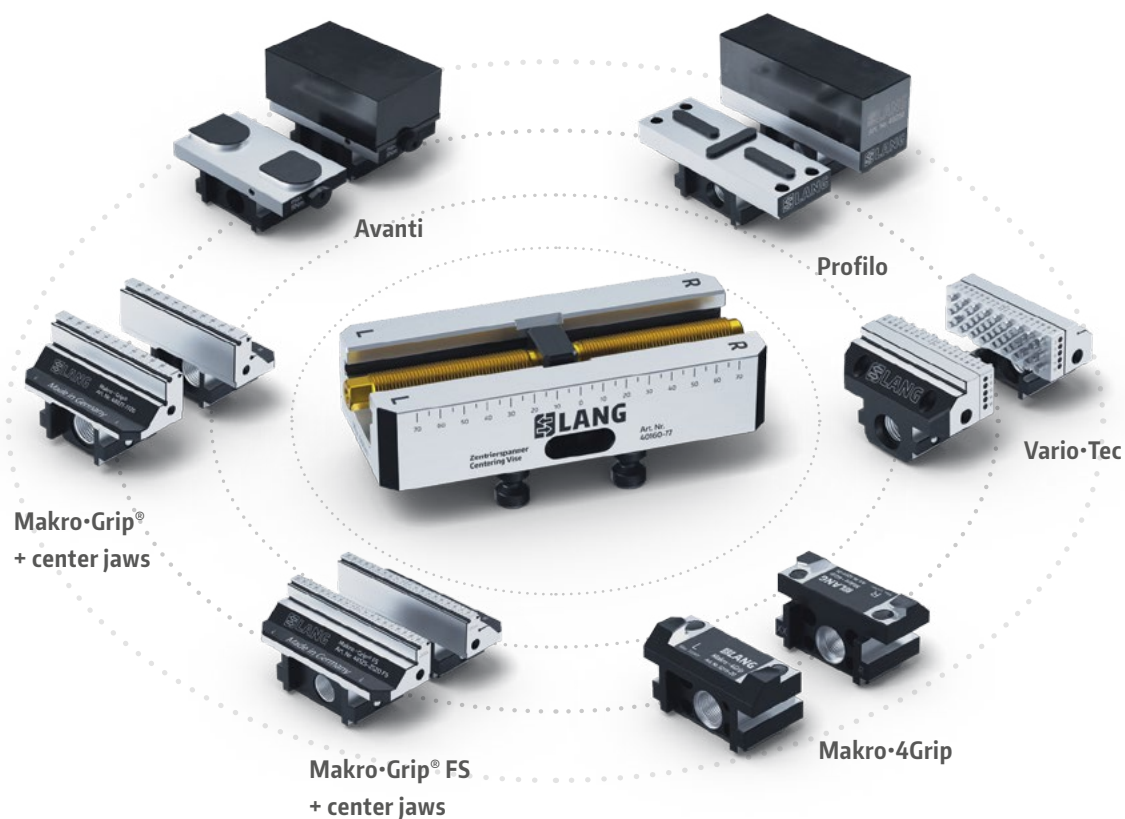

How many different clamping tasks are you facing? Don't worry, because with our vises from LANG Technik you are perfectly well equipped. No matter which type of clamping jaw is required, our vises are universally compatible and offer you the option of replacing the jaws effortlessly. A real added value for your range of components and also very cost-efficient.

- **Makro-Grip®**
Clamping jaws with regular serration for clamping blanks
- **Makro-Grip® FS**
Clamping jaws with full serration for clamping blanks
- **Makro-4Grip**
Clamping jaws for cylindrical blanks
- **Avanti**
Clamping jaws for contour parts
- **Profilo**
Clamping jaws for contour parts
- **Vario-Tec**
Clamping jaws with support and end stop system

Other clamping solutions:

Our **Makro-Grip® Ultra** clamping system is the solution for all your applications. Modular and versatile, it covers clamping ranges of up to 1,000 mm and leaves nothing to be desired.

For machining cylindrical components, we offer **Vasto-Clamp** and **Preci-Point**, versatile clamping and collet chucks that perfectly complement our clamping portfolio. What all our clamping technology solutions have in common? An integrated zero point adaptation for a fast and precise set-up process.

All-around machining through jaw exchange

1. clamping operation



2. clamping operation



LANG offers a suitable solution for every challenging clamping task – and all you need is a single vise! All LANG Technik centering vises use the same base body in different lengths and widths. The interchangeability of the different clamping jaw types allows you to flexibly build up your “vise fleet”. Depending on your needs and requirements, suitable jaw types can be added. An investment in several vises is therefore not absolutely necessary.

The examples above show different parts after the first and before the second clamping operation – in each case first with the Makro-Grip® 5-axis vise and then with our three clamping jaw types Vario-Tec, Profilo and Avanti.

Centering vise **base 77** for jaw width 46 mm



CENTERING VISE BASE 77 FOR JAW WIDTH 46 MM



ITEM NO.	BASE BODY LENGTH	BASE BODY WIDTH	WEIGHT
40085-46	102 mm	77 mm	1.6 kg
40120-46 *	130 mm	77 mm	2.0 kg

* Suitable for use in the RoboTrex and RoboTrex Compact automation systems.

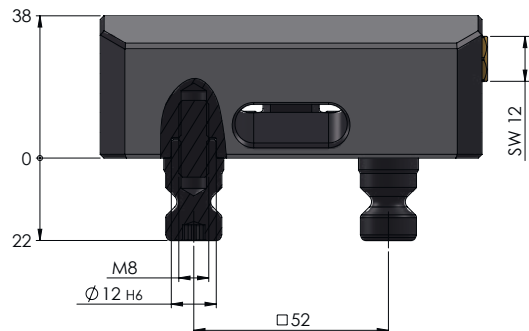
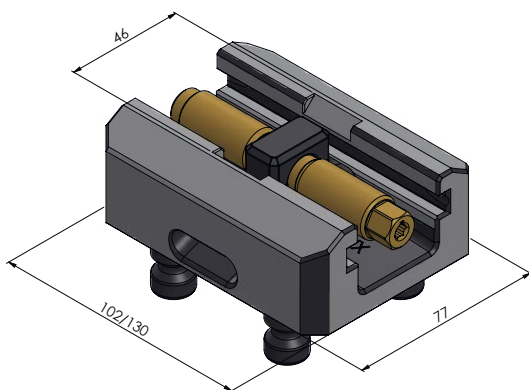

Suitable jaw variants:

Makro-4Grip: **57708-20 / 57711-20**
 Avanti: **44771-46 / 44771-77**
 Profilo: **49077**
 Vario-Tec: **42018-77**

Clamping jaws: **48085-4620 / 48077-4620**
 Clamping jaws with FS serration: **48085-4620 FS / 48077-4620 FS**
 Non-serrated clamping jaws: **48085-4622 / 48077-4622**

Due to the identical size of the jaw guide, these three variants can also be used with a jaw width of 77 mm.

Centering vise **base 77** for jaw width 77 mm



CENTERING VISE BASE 77 FOR JAW WIDTH 77 MM



ITEM NO.	BASE BODY LENGTH	BASE BODY WIDTH	WEIGHT
40085-77	102 mm	77 mm	1.7 kg
40120-77*	130 mm	77 mm	2.1 kg
40160-77	170 mm	77 mm	2.8 kg
40200-77	210 mm	77 mm	3.5 kg

* Suitable for use in the RoboTrex and RoboTrex Compact automation systems.

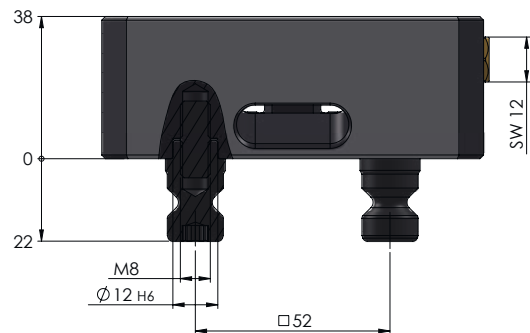
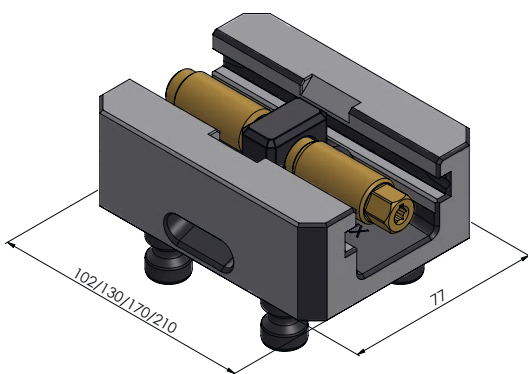

Suitable jaw variants:

Makro-4Grip: **57708-20 | 57711-20**
Avanti: **44771-46 | 44771-77**
Profilo: **49077**
Vario-Tec: **42018-77**

Clamping jaws: **48085-7720 | 48077-7720**
Clamping jaws with FS serration: **48085-7720 FS | 48077-7720 FS**
Non-serrated clamping jaws: **48085-7722 | 48077-7722**

Due to the identical size of the jaw guide, these three variants can also be used with a jaw width of 46 mm.

Centering vise **base 125** for jaw width 77 mm



CENTERING VISE BASE 125 FOR JAW WIDTH 77 MM



ITEM NO.	BASE BODY LENGTH	BASE BODY WIDTH	WEIGHT
40155-77	160 mm	77 mm	5.5 kg
40205-77*	210 mm	77 mm	7.2 kg

* Suitable for use in the RoboTrex96 automation system.

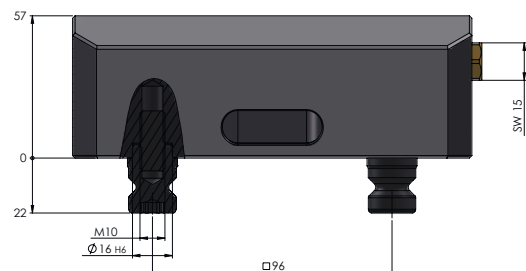
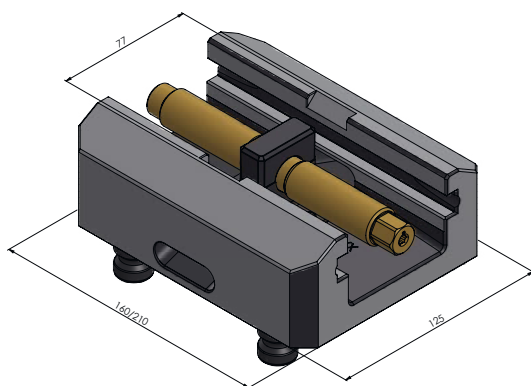

Suitable jaw variants:

Makro-4Grip: **52515-20 / 52530-20**
 Avanti: **44251-125**
 Profilo: **49125**
 Vario-Tec: **42018-125**

Clamping jaws: **48125-7720**
 Clamping jaws with FS serration: **48125-7720 FS**
 Non-serrated clamping jaws: **48125-7722**

Due to the identical size of the jaw guide, these three variants can also be used with a jaw width of 125 mm.

Centering vise **base 125** for jaw width 125 mm



CENTERING VISE BASE 125 FOR JAW WIDTH 125 MM



ITEM NO.	BASE BODY LENGTH	BASE BODY WIDTH	WEIGHT
40155-125	160 mm	125 mm	5.9 kg
40205-125 *	210 mm	125 mm	7.6 kg
40255-125	260 mm	125 mm	9.6 kg
40305-125	310 mm	125 mm	11.5 kg
40355-125	360 mm	125 mm	13.3 kg

* Suitable for use in the RoboTrex96 automation system.

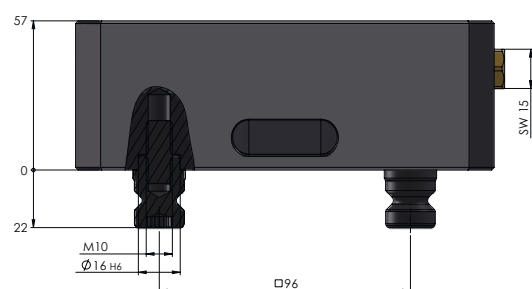
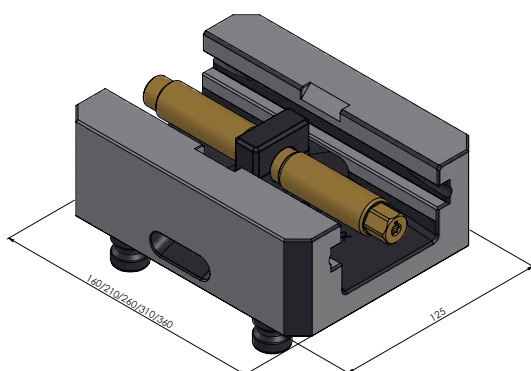

Suitable jaw variants:

Makro-4Grip: **52515-20 / 52530-20**
Avanti: **44251-125**
Profilo: **49125**
Vario-Tec: **42018-125**

Clamping jaws: **48125-2520**
Clamping jaws with FS serration: **48125-2520 FS**
Non-serrated clamping jaws: **48125-2522**

Due to the identical size of the jaw guide, these three variants can also be used with a jaw width of 77 mm.

Makro-Grip® spare jaws with regular serration



SPARE JAWS FOR MAKRO-GRIP® 46 (MICRO) JAW WIDTH 46 MM

ITEM NO.	FOR	WEIGHT	QTY
48046-4620	48040-46 / 48065-46	0.3 kg	1 pair



SPARE JAWS FOR MAKRO-GRIP® 77 JAW WIDTH 46 MM

ITEM NO.	FOR	WEIGHT	QTY
48085-4620	48085-46	0.5 kg	1 pair
48077-4620	48120-46	0.6 kg	1 pair



SPARE JAWS FOR MAKRO-GRIP® 77 JAW WIDTH 77 MM

ITEM NO.	FOR	WEIGHT	QTY
48085-7720	48085-77	0.8 kg	1 pair
48077-7720	48120-77 / 48160-77 / 48200-77	0.8 kg	1 pair



SPARE JAWS FOR MAKRO-GRIP® 125 JAW WIDTH 77 MM

ITEM NO.	FOR	WEIGHT	QTY
48125-7720	all Makro-Grip® 125 with jaw width 77 mm	2.0 kg	1 pair



SPARE JAWS FOR MAKRO-GRIP® 125 JAW WIDTH 125 MM

ITEM NO.	FOR	WEIGHT	QTY
48125-2520	all Makro-Grip® 125 with jaw width 125 mm	2.6 kg	1 pair

Makro·Grip® non-serrated spare jaws



SPARE JAWS FOR MAKRO·GRIP® 46 (MICRO) JAW WIDTH 46 MM, NON-SERRATED

ITEM NO.	FOR	WEIGHT	QTY
48046-4622	48040-46 / 48065-46	0.3 kg	1 pair



SPARE JAWS FOR MAKRO·GRIP® 77 JAW WIDTH 46 MM, NON-SERRATED

ITEM NO.	FOR	WEIGHT	QTY
48085-4622	48085-46	0.5 kg	1 pair
48077-4622	48120-46	0.6 kg	1 pair



SPARE JAWS FOR MAKRO·GRIP® 77 JAW WIDTH 77 MM, NON-SERRATED

ITEM NO.	FOR	WEIGHT	QTY
48085-7722	48085-77	0.8 kg	1 pair
48077-7722	48120-77 / 48160-77 / 48200-77	0.8 kg	1 pair



SPARE JAWS FOR MAKRO·GRIP® 125 JAW WIDTH 77 MM, NON-SERRATED

ITEM NO.	FOR	WEIGHT	QTY
48125-7722	all Makro-Grip® 125 with jaw width 77 mm	2.0 kg	1 pair



SPARE JAWS FOR MAKRO·GRIP® 125 JAW WIDTH 125 MM, NON-SERRATED

ITEM NO.	FOR	WEIGHT	QTY
48125-2522	all Makro-Grip® 125 with jaw width 125 mm	2.6 kg	1 pair

Makro-Grip® 77 center jaws and spindles for multiple clamping

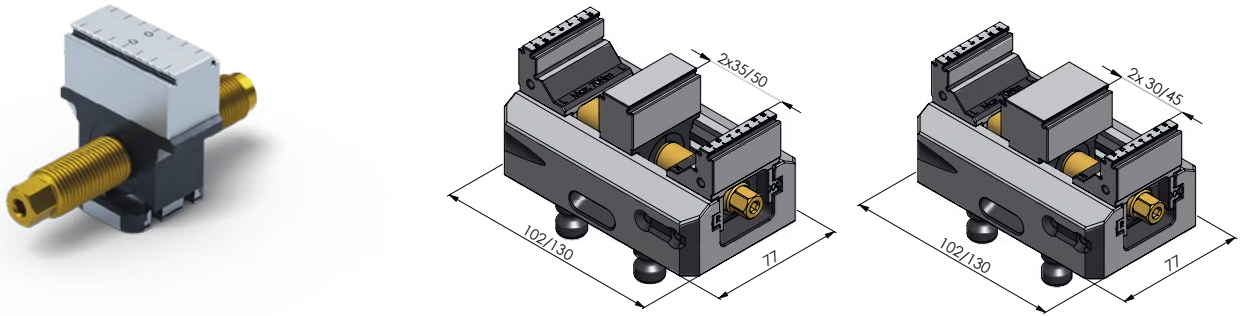

CENTER JAW AND SPINDLE FOR MAKRO-GRIP® 5-AXIS VISE 77 JAW WIDTH 46 MM

ITEM NO.	FOR MAKRO-GRIP®	CENTER JAW WIDTH	SPINDLE LENGTH	CLAMPING RANGE
48085-TG4617	48085-46	17 mm	100 mm	2 × 35 mm
48085-TG4627	48085-46	27 mm	100 mm	2 × 30 mm
48120-TG4617	48120-46	17 mm	135 mm	2 × 50 mm
48120-TG4627	48120-46	27 mm	135 mm	2 × 45 mm

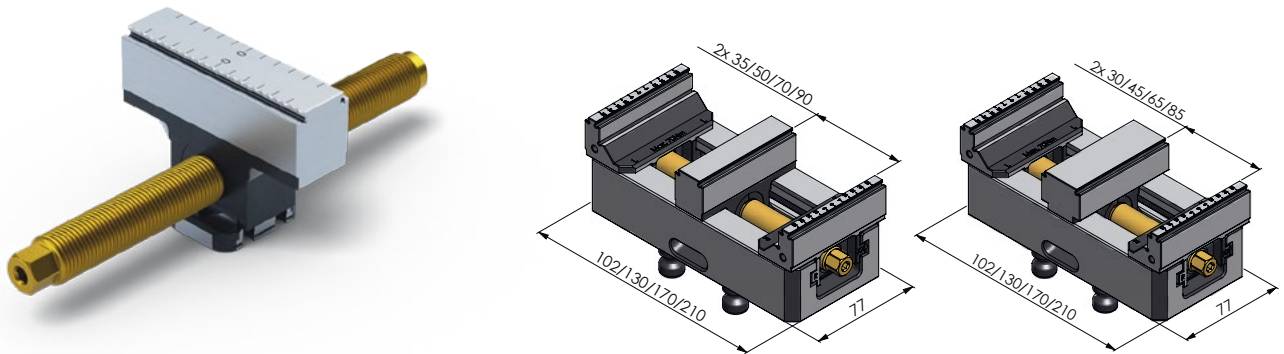

CENTER JAW AND SPINDLE FOR MAKRO-GRIP® 5-AXIS VISE 77 JAW WIDTH 77 MM

ITEM NO.	FOR MAKRO-GRIP®	CENTER JAW WIDTH	SPINDLE LENGTH	CLAMPING RANGE
48085-TG7717	48085-77	17 mm	100 mm	2 × 35 mm
48085-TG7727	48085-77	27 mm	100 mm	2 × 30 mm
48120-TG7717	48120-77	17 mm	135 mm	2 × 50 mm
48120-TG7727	48120-77	27 mm	135 mm	2 × 45 mm
48160-TG7717	48160-77	17 mm	175 mm	2 × 70 mm
48160-TG7727	48160-77	27 mm	175 mm	2 × 65 mm
48200-TG7717	48200-77	17 mm	215 mm	2 × 90 mm
48200-TG7727	48200-77	27 mm	215 mm	2 × 85 mm

Makro-Grip® 125 center jaws and spindles for multiple clamping

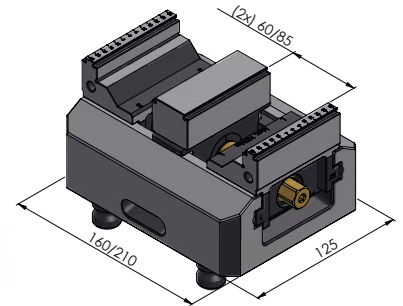
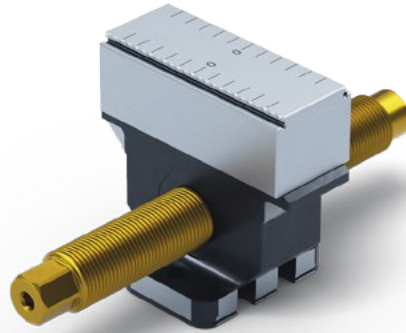

CENTER JAW AND SPINDLE FOR MAKRO-GRIP® 5-AXIS VISE 125 JAW WIDTH 77 MM

ITEM NO.	FOR MAKRO-GRIP®	CENTER JAW WIDTH	SPINDLE LENGTH	CLAMPING RANGE
48155-TG7727	48155-77	27 mm	164 mm	2 × 60 mm
48205-TG7727	48205-77	27 mm	214 mm	2 × 85 mm

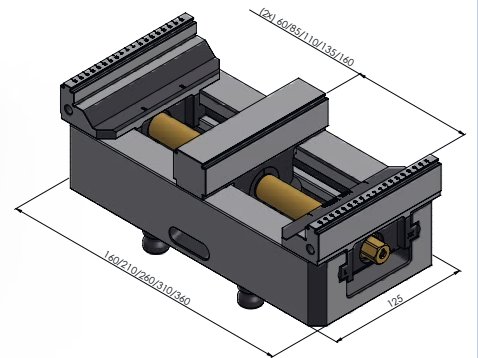
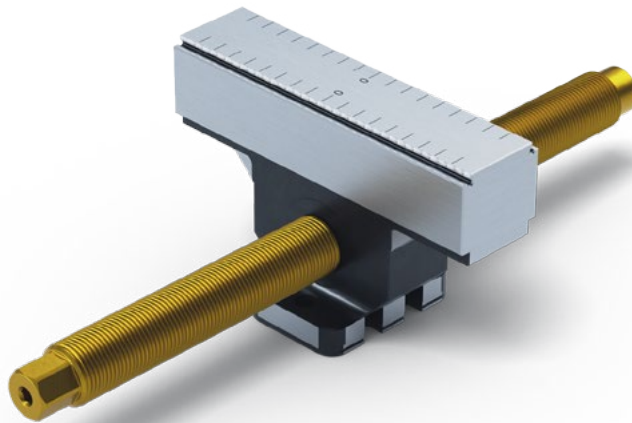

CENTER JAW AND SPINDLE FOR MAKRO-GRIP® 5-AXIS VISE 125 JAW WIDTH 125 MM

ITEM NO.	FOR MAKRO-GRIP®	CENTER JAW WIDTH	SPINDLE LENGTH	CLAMPING RANGE
48155-TG2527	48155-125	27 mm	164 mm	2 × 60 mm
48205-TG2527	48205-125	27 mm	214 mm	2 × 85 mm
48255-TG2527	48255-125	27 mm	264 mm	2 × 110 mm
48305-TG2527	48305-125	27 mm	314 mm	2 × 135 mm
48355-TG2527	48355-125	27 mm	364 mm	2 × 160 mm

Makro-Grip® FS 46 and 77 clamping jaws with full serration



CLAMPING JAWS FOR MAKRO-GRIP® 46 (MICRO) JAW WIDTH 46 MM

ITEM NO.	FOR	WEIGHT	QTY
48046-4620 FS	48040-46 / 48065-46	0.3 kg	1 pair



CLAMPING JAWS FOR CENTERING VISE 77 JAW WIDTH 46 MM

ITEM NO.	FOR	WEIGHT	QTY
48085-4620 FS	40085-46	0.5 kg	1 pair
48077-4620 FS	40120-46	0.6 kg	1 pair



CLAMPING JAWS FOR CENTERING VISE 77 JAW WIDTH 77 MM

ITEM NO.	FOR	WEIGHT	QTY
48085-7720 FS	40085-77	0.8 kg	1 pair
48077-7720 FS	40120-77 / 40160-77 / 40200-77	0.8 kg	1 pair

Note

If you want to switch flexibly between Makro-Grip® and Makro-Grip® FS clamping jaws, no program adjustments are necessary due to the same jaw geometry. For this reason, no separate dimensioned models are listed on this page. Please compare the models in the Makro-Grip® chapter on pages 124 to 129.

Makro-Grip® FS 125 clamping jaws with full serration



CLAMPING JAWS FOR CENTERING VISE 125 JAW WIDTH 77 MM

ITEM NO.	FOR	WEIGHT	QTY
48125-7720 FS	all centering vises 125 with jaw width 77 mm	2.0 kg	1 pair



CLAMPING JAWS FOR CENTERING VISE 125 JAW WIDTH 125 MM

ITEM NO.	FOR	WEIGHT	QTY
48125-2520 FS	all centering vises 125 with jaw width 125 mm	2.6 kg	1 pair

Difference to regular serration

The Makro-Grip® FS full serration differs from the regular holding serration by its continuous row of teeth.



Makro-Grip® FS, full serration



Makro-Grip®, regular serration

Area of application

- for soft materials such as aluminium or materials with high toughness and poor machinability, such as titanium alloys and stainless steels
- for slim workpieces where only a few clamping teeth are engaged
- for high cutting rates in combination with both of the above points

For more information about Makro-Grip® and Makro-Grip® FS, please refer to pages 102 to 103.

Makro·Grip® FS 77 center jaws and spindles for multiple clamping



Due to identical dimensions and interfering contours with the regular Makro·Grip® center jaws, no separate dimensioned models are listed on this page.

Please compare the models on pages 142 to 143.

CENTER JAW AND SPINDLE FOR CENTERING VISE 77 JAW WIDTH 46 MM

ITEM NO.	FOR CENTERING VISE	CENTER JAW WIDTH	SPINDLE LENGTH	CLAMPING RANGE
48085-TG4617 FS	40085-46	17 mm	100 mm	2 × 35 mm
48085-TG4627 FS	40085-46	27 mm	100 mm	2 × 30 mm
48120-TG4617 FS	40120-46	17 mm	135 mm	2 × 50 mm
48120-TG4627 FS	40120-46	27 mm	135 mm	2 × 45 mm

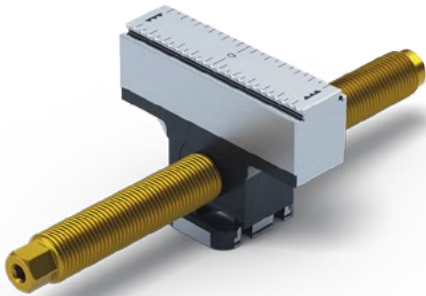

CENTER JAW AND SPINDLE FOR CENTERING VISE 77 JAW WIDTH 77 MM

ITEM NO.	FOR CENTERING VISE	CENTER JAW WIDTH	SPINDLE LENGTH	CLAMPING RANGE
48085-TG7717 FS	40085-77	17 mm	100 mm	2 × 35 mm
48085-TG7727 FS	40085-77	27 mm	100 mm	2 × 30 mm
48120-TG7717 FS	40120-77	17 mm	135 mm	2 × 50 mm
48120-TG7727 FS	40120-77	27 mm	135 mm	2 × 45 mm
48160-TG7717 FS	40160-77	17 mm	175 mm	2 × 70 mm
48160-TG7727 FS	40160-77	27 mm	175 mm	2 × 65 mm
48200-TG7717 FS	40200-77	17 mm	215 mm	2 × 90 mm
48200-TG7727 FS	40200-77	27 mm	215 mm	2 × 85 mm

Makro·Grip® FS 125 center jaws and spindles for multiple clamping

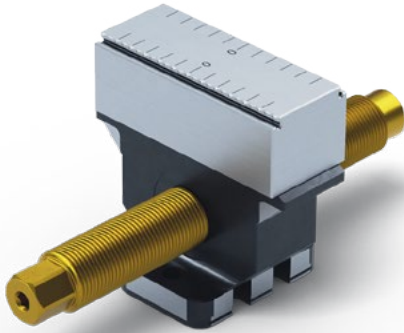

CENTER JAW AND SPINDLE FOR CENTERING VISE 125 JAW WIDTH 77 MM

ITEM NO.	FOR CENTERING VISE	CENTER JAW WIDTH	SPINDLE LENGTH	CLAMPING RANGE
48155-TG7727 FS	40155-77	27 mm	164 mm	2 × 60 mm
48205-TG7727 FS	40205-77	27 mm	214 mm	2 × 85 mm

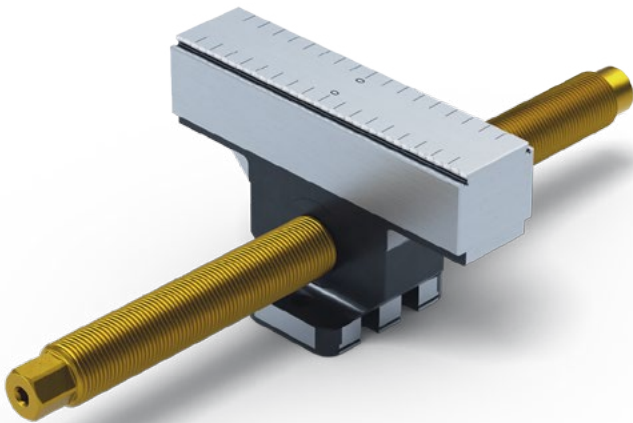

CENTER JAW AND SPINDLE FOR CENTERING VISE 125 JAW WIDTH 125 MM

ITEM NO.	FOR CENTERING VISE	CENTER JAW WIDTH	SPINDLE LENGTH	CLAMPING RANGE
48155-TG2527 FS	40155-125	27 mm	164 mm	2 × 60 mm
48205-TG2527 FS	40205-125	27 mm	214 mm	2 × 85 mm
48255-TG2527 FS	40255-125	27 mm	264 mm	2 × 110 mm
48305-TG2527 FS	40305-125	27 mm	314 mm	2 × 135 mm
48355-TG2527 FS	40355-125	27 mm	364 mm	2 × 160 mm



PATENTED

Makro·4Grip

clamping jaws for cylindrical blanks

Makro·4Grip is an innovative technology that makes it possible to use LANG Technik's proven stamping technology for cylindrical materials as well. The form-fit clamping of pre-stamped, cylindrical components achieves maximum holding forces despite low clamping pressure, resulting in maximum process reliability. With a minimum clamping pressure, round components with a support height of just 3 mm can be clamped without distortion. Makro·4Grip is available as an additional pair of jaws for the 5-axis vise (and the stamping unit), which means there are no acquisition costs for additional chucks.

Primary area of application:

- **Form-fit clamping via holding serration**
- **Cylindrical components**
- **1st clamping operation, raw part machining**

Benefits:

- **Highest holding forces and maximum process reliability**
- **High material and cost savings thanks to minimal clamping edge requirements**
- **No need to invest in additional chucks**

Makro·4Grip round part clamping

Stamping technology for cylindrical blanks

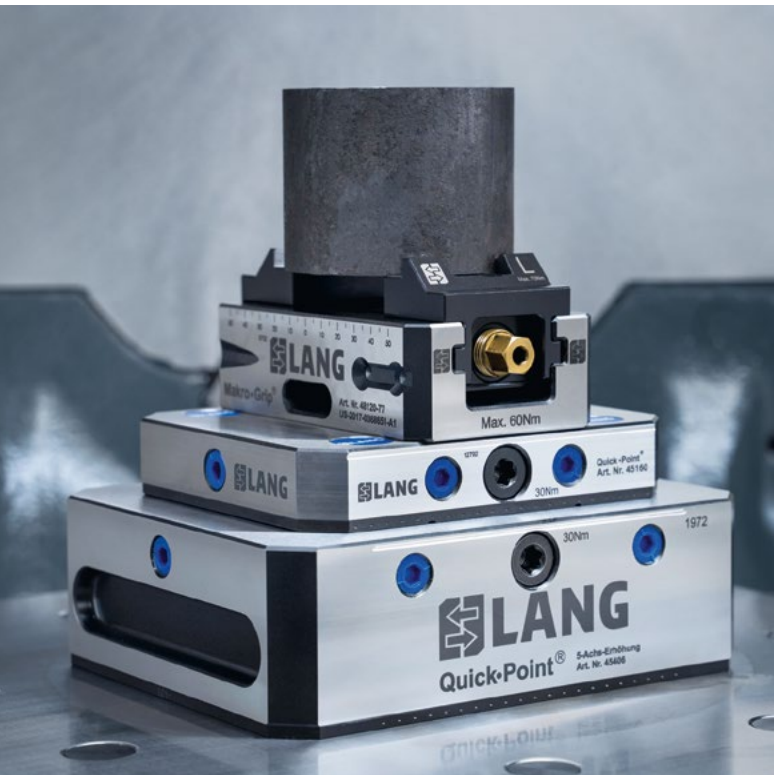

By retrofitting the Makro-Grip® stamping unit and LANG centering vises the form-fit clamping technology can be applied for cylindrical blanks easily and cost efficiently. The jaws grip the pre-stamped part in four indentations at a clamping depth of 6.5 mm with up to 20 kN and therefore realize the same form-fit effect as for the well-proven system for prismatic parts.

Makro·4Grip covers a clamping range of Ø 36 mm to Ø 300 mm and thus provides a seamless transition from the maximum range of the Preci-Point collet chuck.

The Makro·4Grip system consists of universal stamping jaws including stamping inserts for individual positioning as well as matching clamping jaws for all sizes of LANG centering vises. The clamping jaws are available as a separate set of jaws for all 77 and 125 vises.

Stamping imprint

Opposed to pre-stamping cuboid blanks with regularly serrated stamping jaws where control marks give an indication about the correct stamping depth, the Makro·4Grip technology relies on a visual examination. Stamping round material, the correct imprint is consistently thick and deep.

The required stamping pressure and depth depends on material and its diameter. In general, we recommend always starting with a low stamping pressure and slowly increasing it until the desired stamping depth in the workpiece is achieved.



Makro·4Grip stamping jaws and inserts

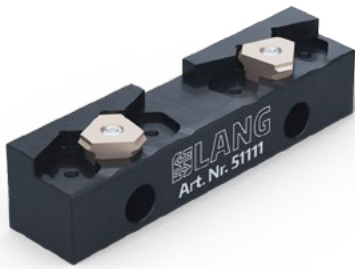

MAKRO·4GRIP STAMPING JAWS

ITEM NO.	FOR MATERIALS	QTY
51111	up to 45 HRC	1 pair

Includes: 4 stamping jaw inserts

Suitable for all Makro·Grip® stamping unit versions!



MAKRO·4GRIP STAMPING JAW INSERTS

ITEM NO.	QTY
51111-40	4 pcs.

Each stamping jaw insert has a total of three cutting edges. If a cutting edge is worn, the stamping jaw insert can be turned two more times. For an even stamping and clamping quality, make sure that all four stamping inserts are turned / exchanged at the same time.

Makro·4Grip stamping technology – the right setup

According to the vise and clamping jaw size used in the machining process, the four stamping inserts (2 inserts per stamping jaw) are placed differently in the respective seats. The scheme below shows

how the stamping inserts need to be positioned for each clamping setup. Makro·4Grip clamping jaws and their clamping ranges can be found on pages 152 to 155.

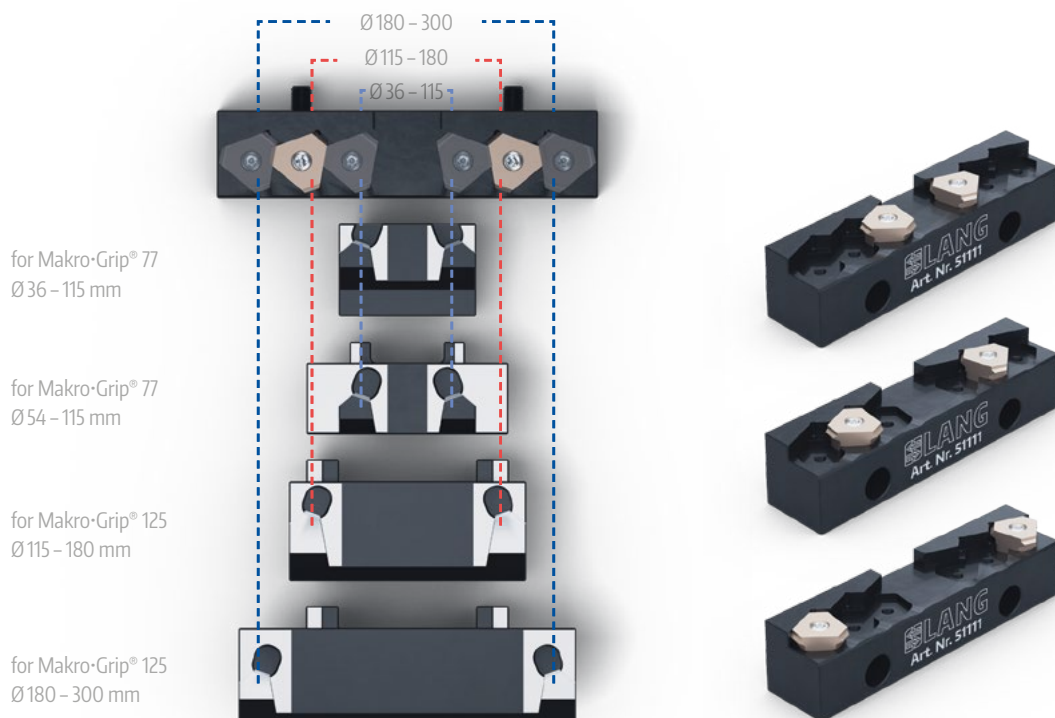

Makro·4Grip 77 clamping jaws



MAKRO-4GRIP 77 CLAMPING JAWS JAW WIDTH 52 MM, ITEM NO. 57708-20

FOR CENTERING VISE 77	CLAMPING RANGE
40085-46 / -77 *	Ø 36 - 60 mm
40120-46 / -77 *	Ø 36 - 85 mm
40160 -77 *	Ø 36 - 115 mm
40200-77 *	Ø 36 - 115 mm
47085 **	Ø 43 - 60 mm
47120 **	Ø 43 - 85 mm
47160 **	Ø 43 - 115 mm
47200 **	Ø 43 - 115 mm

* also suitable for 5-axis vises starting with 48...

** Former Makro·Grip® versions.

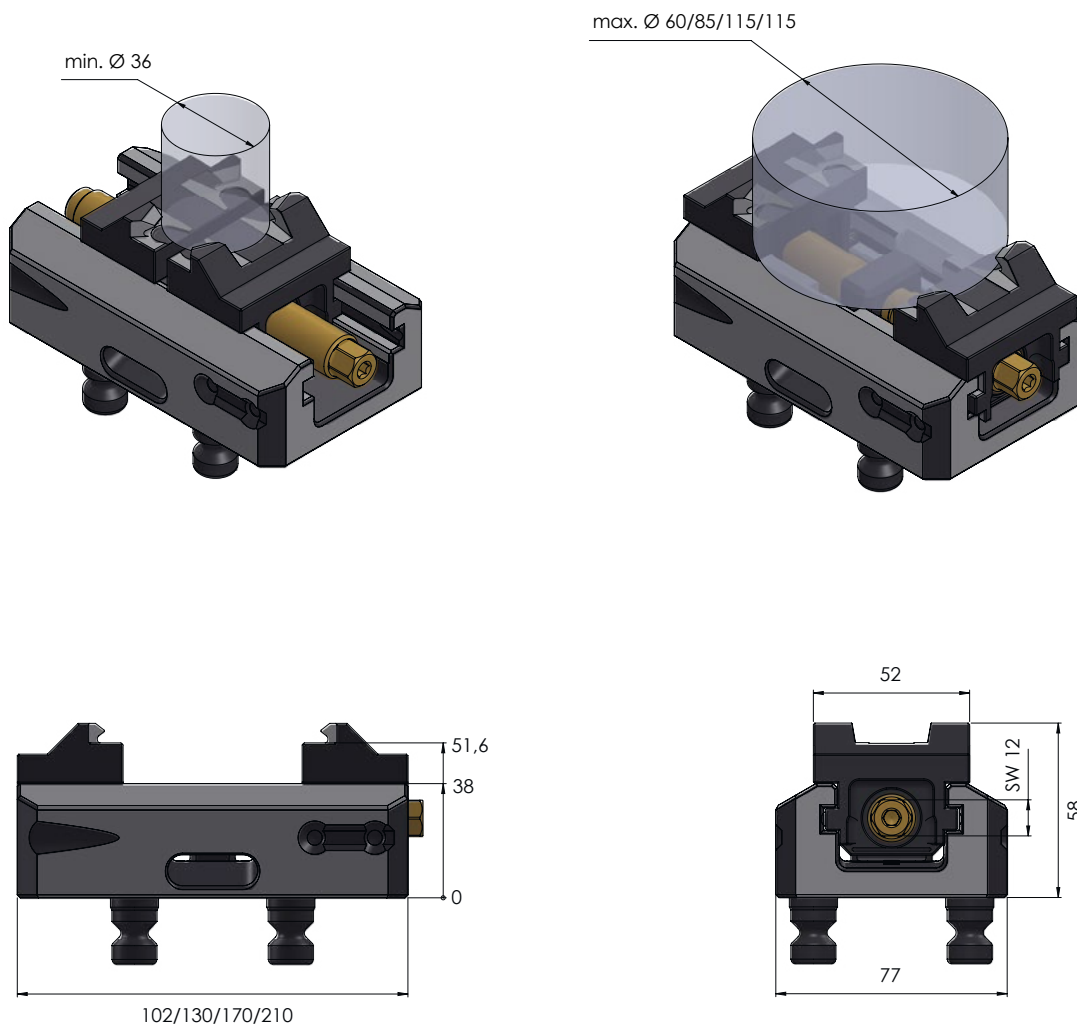



MAKRO-4GRIP 77 CLAMPING JAWS
JAW WIDTH 77 MM, ITEM NO. 57711-20

FOR CENTERING VISE 77	CLAMPING RANGE
40085-46 -77 *	Ø 54 – 80 mm
40120-46 -77 *	Ø 54 – 115 mm
40160-77 *	Ø 54 – 115 mm
40200-77 *	Ø 54 – 115 mm
47085 **	Ø 65 – 80 mm
47120 **	Ø 65 – 115 mm
47160 **	Ø 65 – 115 mm
47200 **	Ø 65 – 115 mm

* also suitable for 5-axis vises starting with 48...

** Former Makro-Grip® versions.

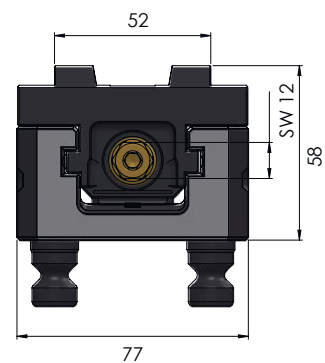
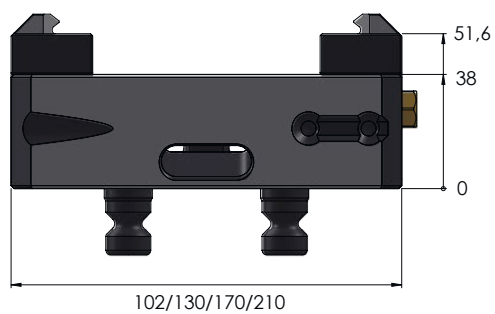
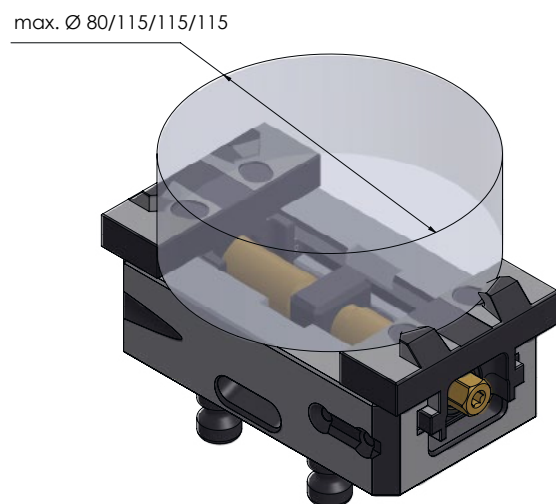
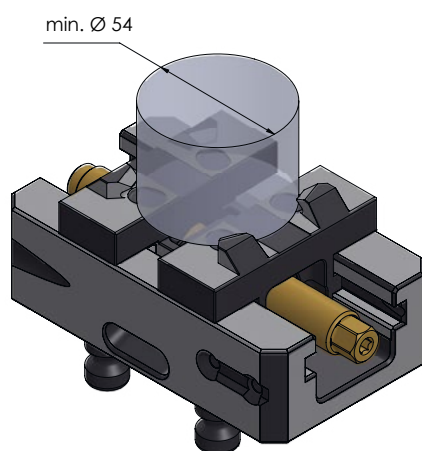

Makro·4Grip 125 clamping jaws



MAKRO-4GRIP 125 CLAMPING JAWS JAW WIDTH 90 MM, ITEM NO. 52515-20

FOR CENTERING VISE 125	CLAMPING RANGE
40155-77 / -125 *	Ø 115 – 130 mm
40205-77 / -125 *	Ø 115 – 180 mm
40255-125 *	Ø 115 – 180 mm
40305-125 *	Ø 115 – 180 mm
40355-125 *	Ø 115 – 180 mm
47155 **	Ø 115 – 130 mm
47205 **	Ø 115 – 180 mm
47255 **	Ø 115 – 180 mm
47305 **	Ø 115 – 180 mm
47355 **	Ø 115 – 180 mm

* also suitable for 5-axis vises starting with 48...

** Former Makro·Grip® versions.

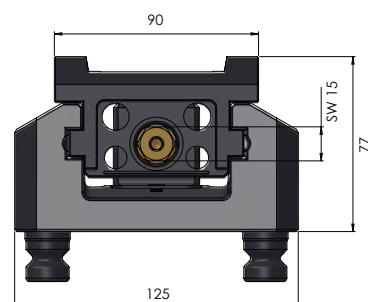
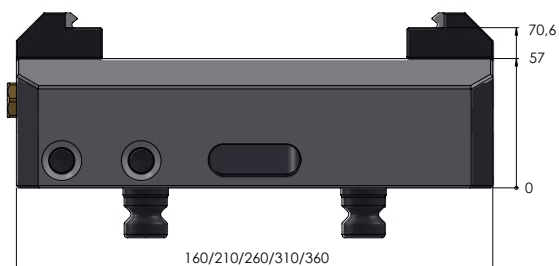
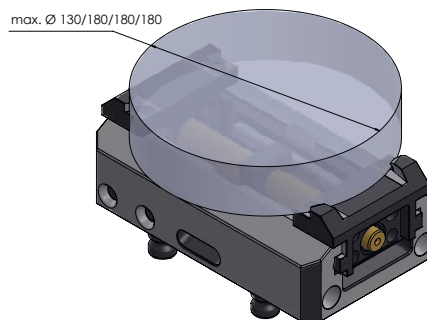
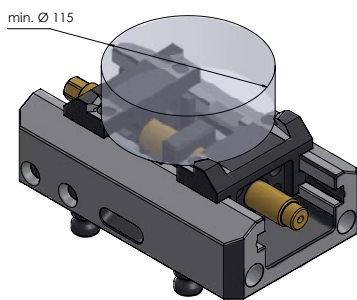



MAKRO-4GRIP 125 CLAMPING JAWS JAW WIDTH 128 MM, ITEM NO. 52530-20

FOR CENTERING VISE 125	CLAMPING RANGE
40155-77 / -125 *	-
40205-77 / -125 *	Ø 180 - 200 mm
40255-125 *	Ø 180 - 245 mm
40305-125 *	Ø 180 - 290 mm
40355-125 *	Ø 180 - 300 mm
47155 **	-
47205 **	Ø 180 - 200 mm
47255 **	Ø 180 - 245 mm
47305 **	Ø 180 - 290 mm
47355 **	Ø 180 - 300 mm

* also suitable for 5-axis vises starting with 48...

** Former Makro-Grip® versions.

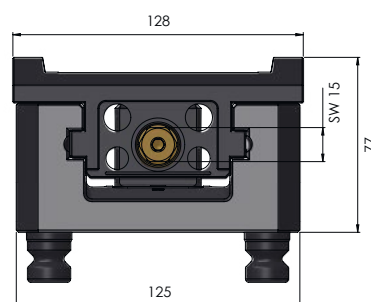
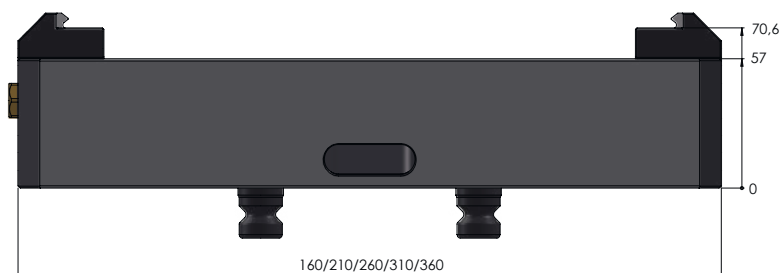
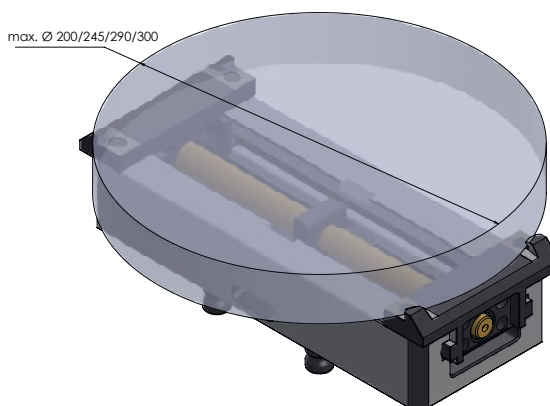
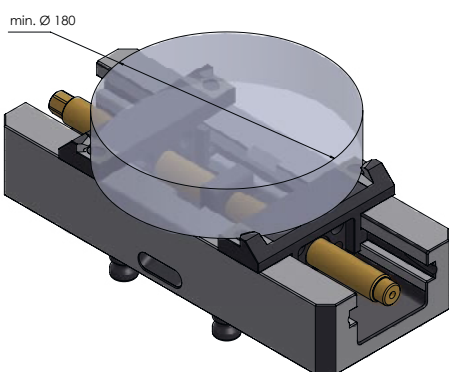

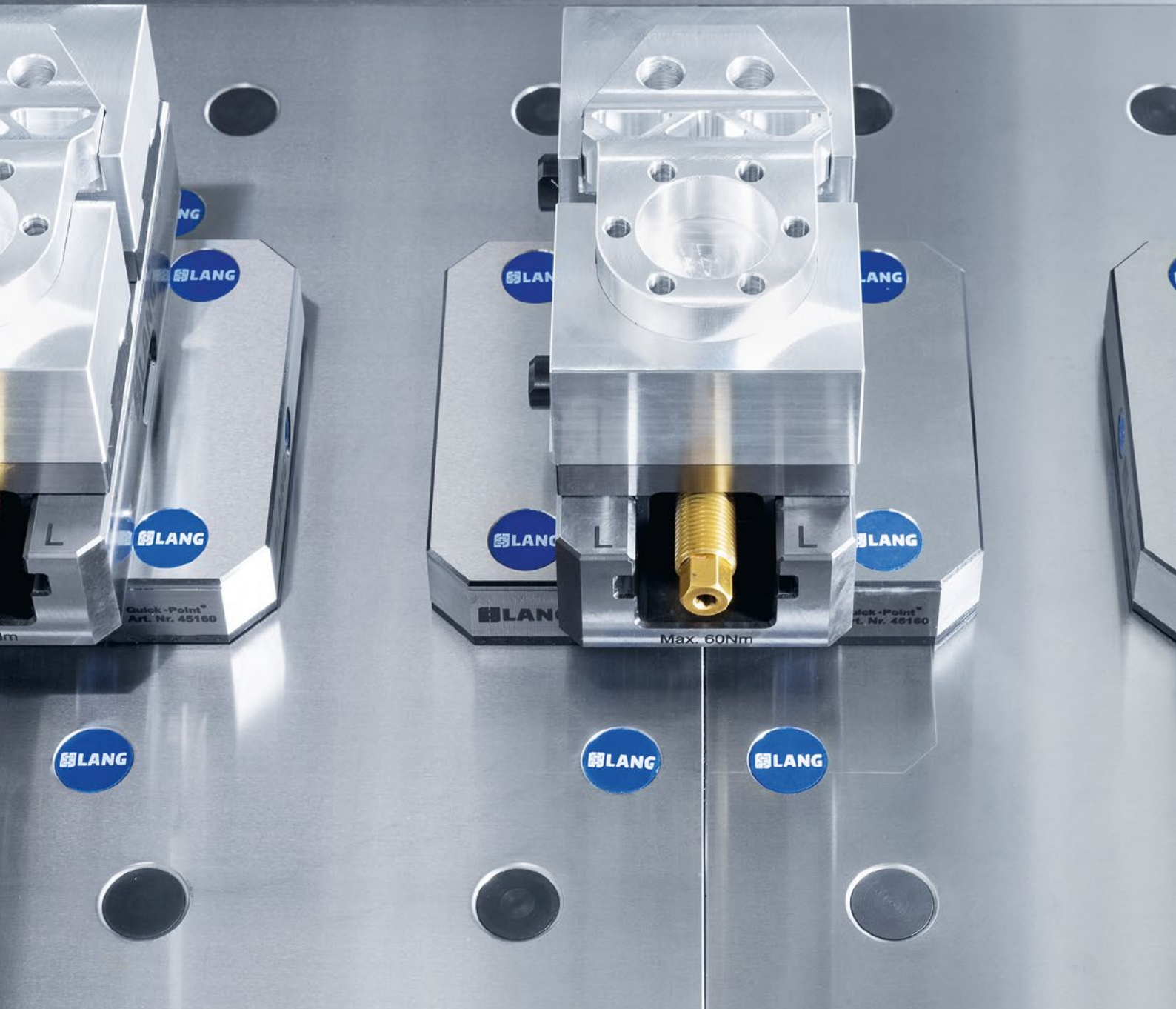

PATENTED

Avanti

clamping jaws for contour clamping

Avanti is a patented contour jaw clamping system for milling that can be used to clamp any workpiece shape. With extremely easy handling characteristics and unbeatably fast mounting of the top jaws, the Avanti is an impressive solution. It is best suited for machining many different parts with frequent changes. The Avanti technology is available as a retrofittable pair of jaws for the 5-axis vise.

Primary area of application:

- **Smooth clamping via friction**
- **Cuboid, cylindrical and pre-machined parts**
- **2nd clamping operation, rear side machining**

Benefits:

- **High set-up time savings thanks to quick jaw exchange**
- **Suitable for all part shapes, therefore enormous variety of applications**
- **Favorable purchase price**



Avanti 46 clamping jaws

jaw width 46 mm

Suitable:



48040-46



48065-46



AVANTI 46 BASE JAWS, JAW WIDTH 46 MM

ITEM NO.	DIMENSIONS	WEIGHT	QTY
44461	55 × 36 mm	0.5 kg	1 pair



AVANTI 46 TOP JAWS, SOFT

ITEM NO.	MATERIAL	DIMENSIONS	MAX. CONTOUR DEPTH	WEIGHT
44468-26	Steel (16MnCr5)	57 × 38 × 26 mm	19 mm	0.4 kg
44469-26	Aluminium (F50)	57 × 38 × 26 mm	19 mm	0.1 kg

Please note: Avanti top jaws are sold individually (not in pairs).

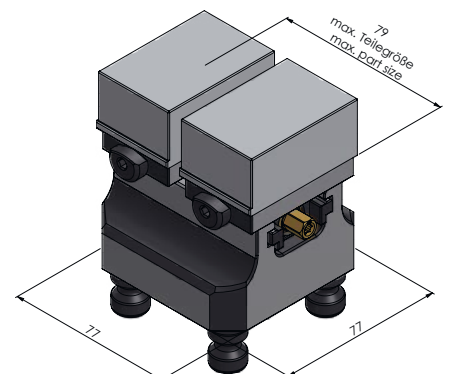
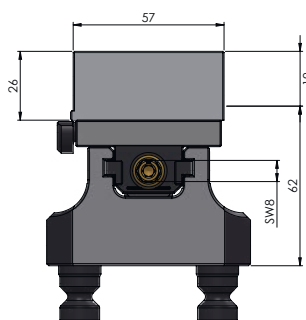
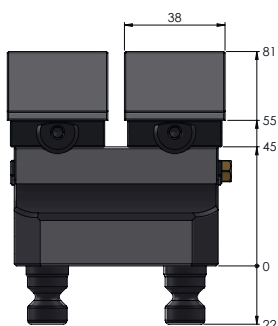
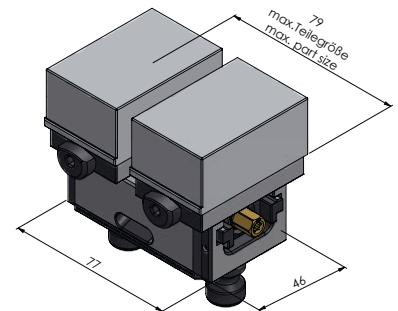
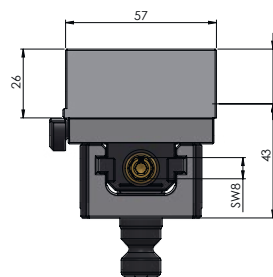
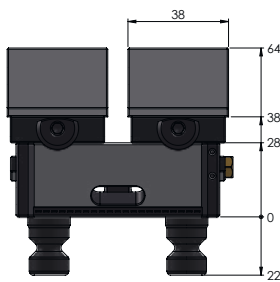

Avanti 77 clamping jaws

jaw width 46 mm

Suitable:



40085-46 /
40120-46



AVANTI 77 BASE JAWS, JAW WIDTH 46 MM

ITEM NO.	DIMENSIONS	WEIGHT	QTY
44771-46	55 × 36 mm	0.6 kg	1 Pair



AVANTI 46 TOP JAWS, SOFT

ITEM NO.	MATERIAL	DIMENSIONS	MAX. CONTOUR DEPTH	WEIGHT
44468-26	Steel (16MnCr5)	57 × 38 × 26 mm	19 mm	0.4 kg
44469-26	Aluminium (F50)	57 × 38 × 26 mm	19 mm	0.1 kg

Please note: Avanti top jaws are sold individually (not in pairs).

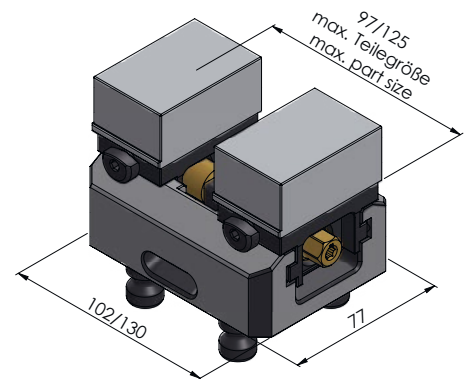
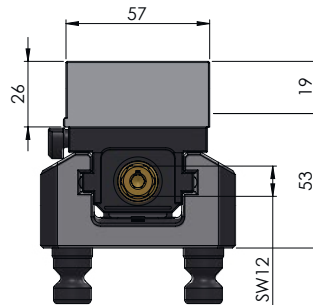
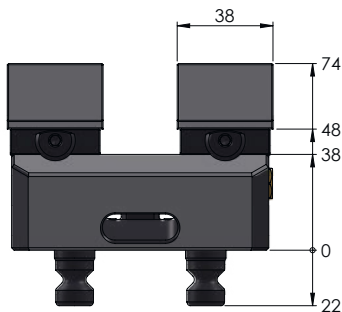

Avanti 77 clamping jaws jaw width 77 mm

Suitable:



40120-46



40120-77 to
40200-77

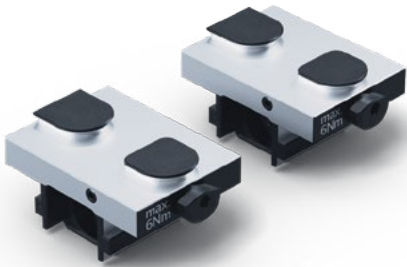

AVANTI 77 BASE JAWS, JAW WIDTH 77 MM

ITEM NO.	DIMENSIONS	WEIGHT	QTY
44771-77	77 × 57 mm	1.4 kg	1 pair

AVANTI 77 TOP JAWS, SOFT



ITEM NO.	MATERIAL	DIMENSIONS	MAX. CONTOUR DEPTH	WEIGHT
44778-36	Steel (16MnCr5)	78 × 58 × 36 mm	29 mm	0.6 kg
44779-36	Aluminium (F50)	78 × 58 × 36 mm	29 mm	0.2 kg
44778-56	Steel (16MnCr5)	78 × 58 × 56 mm	49 mm	1.0 kg
44779-56	Aluminium (F50)	78 × 58 × 56 mm	49 mm	0.3 kg

Please note: Avanti top jaws are sold individually (not in pairs).

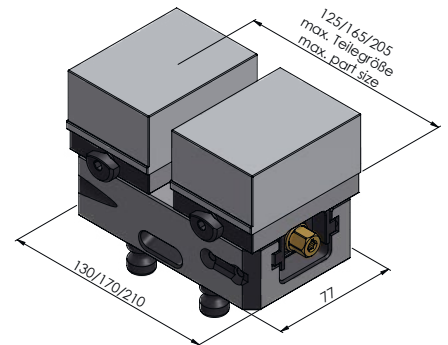
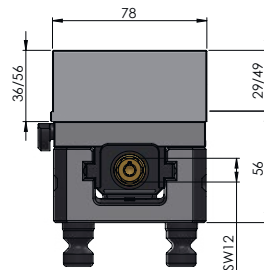
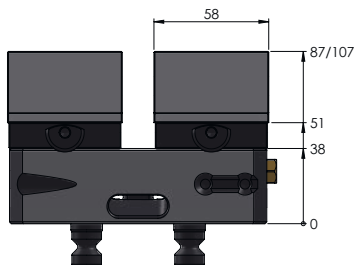

Avanti 125 clamping jaws

jaw width 125 mm

Suitable:



40205-77



40205-125 to
40355-125



AVANTI 125 BASE JAWS 125 MM

ITEM NO.	DIMENSIONS	WEIGHT	QTY
44251-125	125 × 69 mm	3.6 kg	1 pair

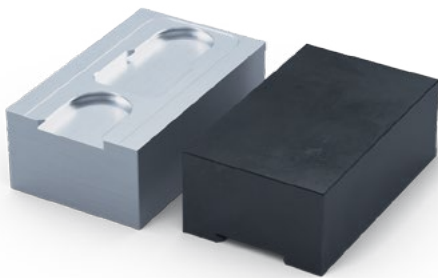

AVANTI 125 TOP JAWS, SOFT

ITEM NO.	MATERIAL	DIMENSIONS	MAX. CONTOUR DEPTH	WEIGHT
44258-46	Steel (16MnCr5)	126 × 77 × 46 mm	39 mm	3.3 kg
44259-46	Aluminium (F50)	126 × 77 × 46 mm	39 mm	1.2 kg
44258-76	Steel (16MnCr5)	126 × 77 × 76 mm	69 mm	5.6 kg
44259-76	Aluminium (F50)	126 × 77 × 76 mm	69 mm	2.0 kg

Please note: Avanti top jaws are sold individually (not in pairs).

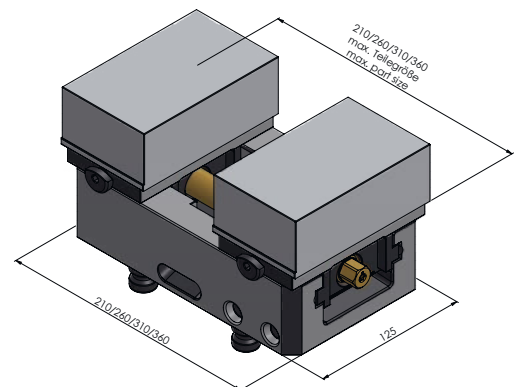
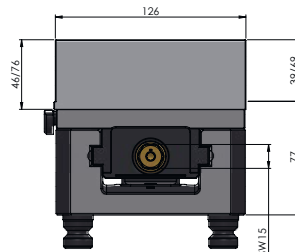
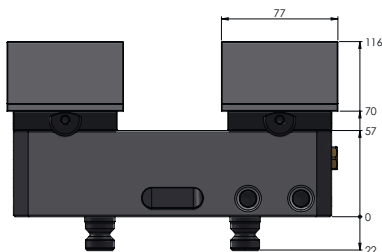

Avanti 77 / 125 center base jaws and spindles

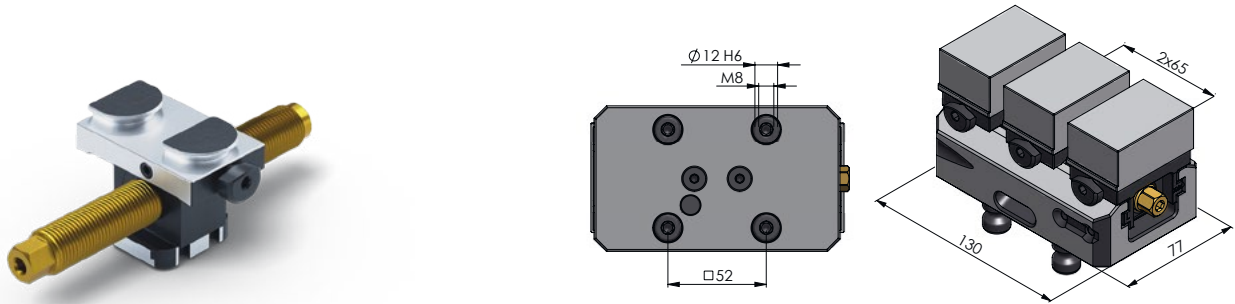

CENTER BASE JAW + SPINDLE FOR CENTERING VISE 77, JAW WIDTH 46 MM

ITEM NO.	SPINDLE LENGTH (+ \varnothing)	FOR CENTERING VISE	WEIGHT
44120-TG46	135 mm (\varnothing 16 mm)	40120-46	0.5 kg

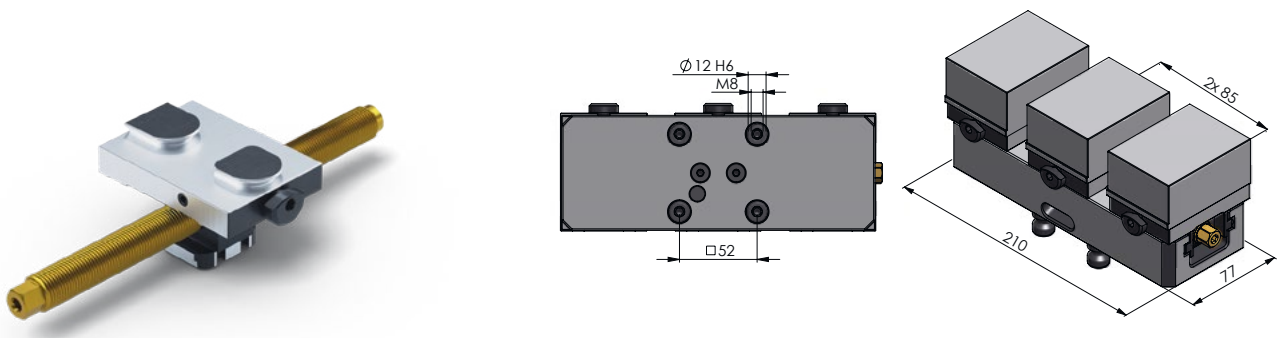

CENTER BASE JAW + SPINDLE FOR CENTERING VISE 77, JAW WIDTH 77 MM

ITEM NO.	SPINDLE LENGTH (+ \varnothing)	FOR CENTERING VISE	WEIGHT
44200-TG77	215 mm (\varnothing 16 mm)	40200-77	0.9 kg

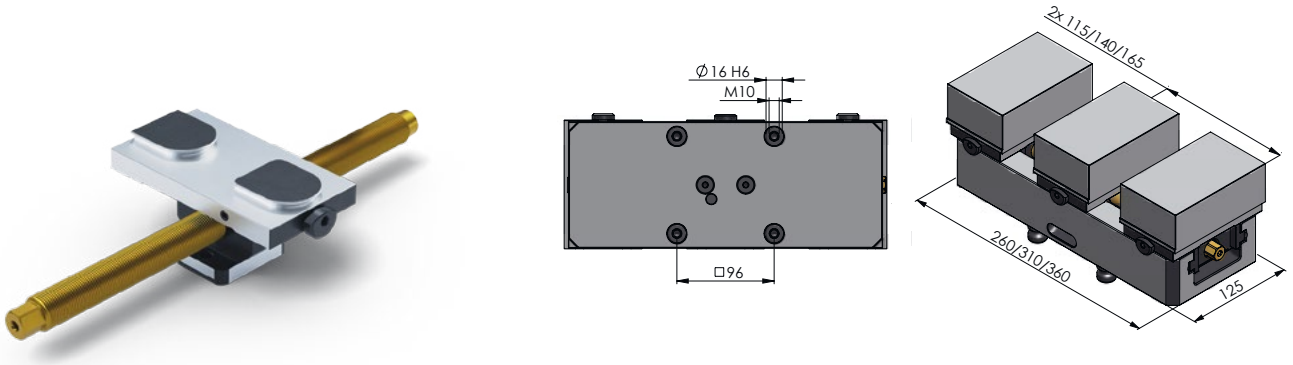

CENTER BASE JAW + SPINDLE FOR CENTERING VISE 125, JAW WIDTH 125 MM

ITEM NO.	SPINDLE LENGTH (+Ø)	FOR CENTERING VISE	WEIGHT
44255-TG125	264 mm (Ø 20 mm)	40255-125	2.0 kg
44305-TG125	314 mm (Ø 20 mm)	40305-125	2.1 kg
44355-TG125	364 mm (Ø 20 mm)	40355-125	2.2 kg

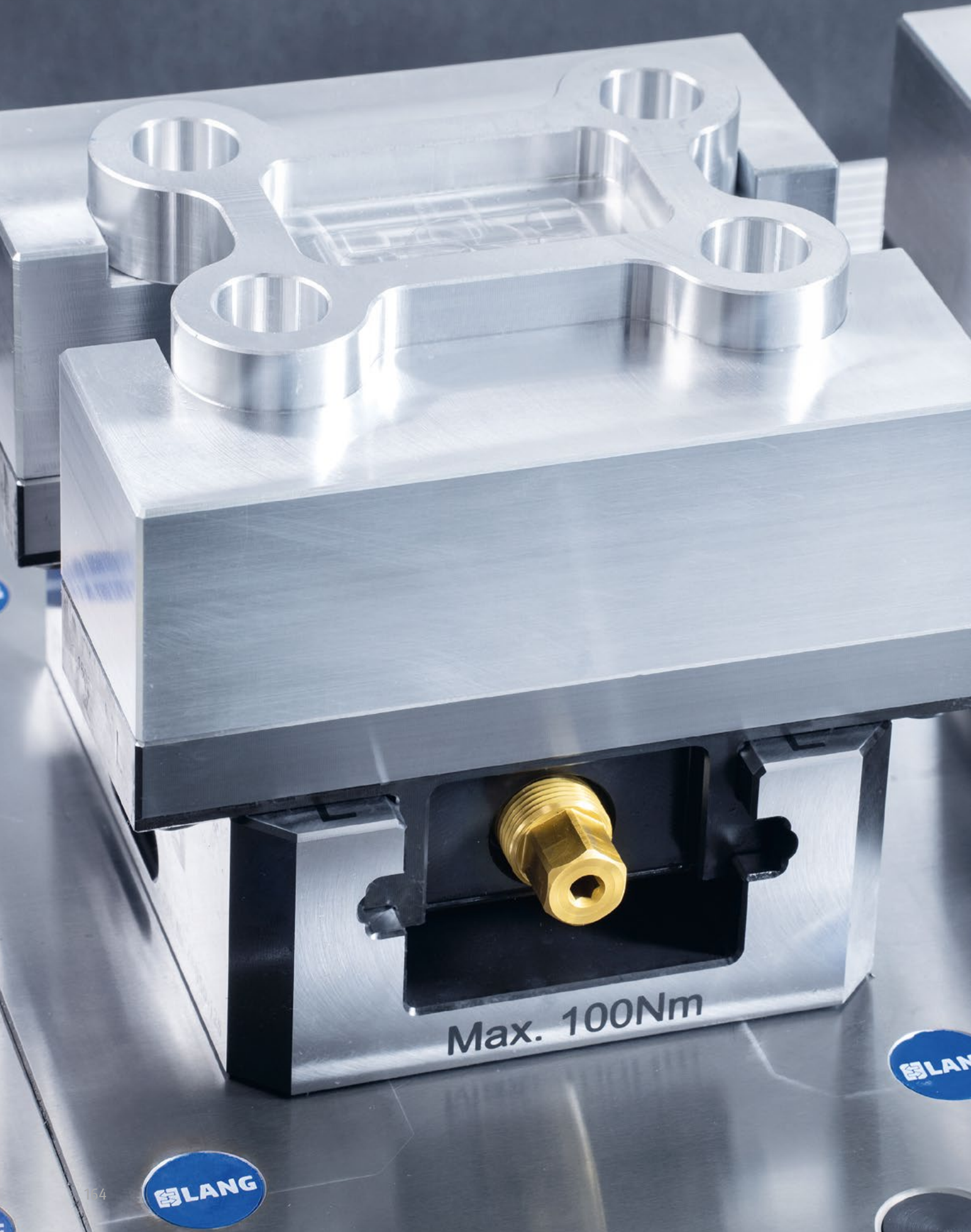

Max. 100Nm





Profilo

clamping jaws for contour clamping

Profilo contour jaw clamping system for milling has enjoyed great popularity for many years. No matter what part shape needs to be clamped, Profilo is always the right solution. Its strengths lie particularly in the possibility of attaching self-made top jaws, which guarantees maximum flexibility and freedom. Profilo technology is available as a retrofittable pair of jaws for the 5-axis vise.

Primary area of application:

- **Smooth clamping via friction**
- **Cuboid, cylindrical and pre-machined parts**
- **2nd clamping operation, rear side machining**

Benefits:

- **Maximum flexibility thanks to in-house production of top jaws**
- **Maximum freedom in the choice of material and the size of the top jaws**
- **Suitable for all part shapes, therefore enormous variety of applications**

Profilo 77 clamping jaws

Suitable:



40085-46 /
40120-46

40085-77 to
40200-77



PROFILO 77 BASE JAWS

ITEM NO.	DIMENSIONS	WEIGHT	QTY
49077	112×46 mm	1.4 kg	1 pair



PROFILO 77 TOP JAWS, SOFT

ITEM NO.	MATERIAL	DIMENSIONS	MAX. CONTOUR DEPTH	WEIGHT
49778	Steel (16MnCr5)	112×57×36 mm	36 mm	1.8 kg
49779	Aluminium (F50)	112×57×36 mm	36 mm	0.6 kg

Please note: Profilo top jaws are sold individually (not in pairs).

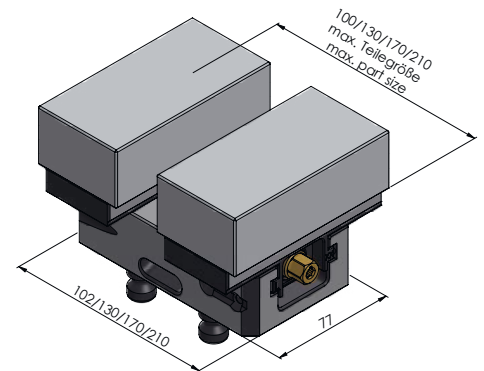
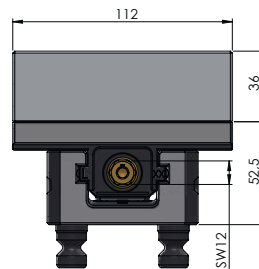
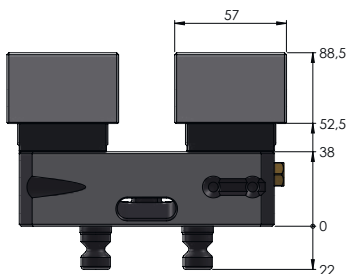

Profilo 125 clamping jaws

Suitable:



40155-77 /
40205-77

40155-125 to
40355-125



PROFILO 125 BASE JAWS

ITEM NO.	DIMENSIONS	WEIGHT	QTY
49125	160×57 mm	4.0 kg	1 pair



PROFILO 125 TOP JAWS, SOFT

ITEM NO.	MATERIAL	DIMENSIONS	MAX. CONTOUR DEPTH	WEIGHT
49258	Steel (16MnCr5)	160×57×47 mm	47 mm	3.3 kg
49259	Aluminium (F50)	160×57×47 mm	47 mm	1.2 kg

Please note: Profilo top jaws are sold individually (not in pairs).

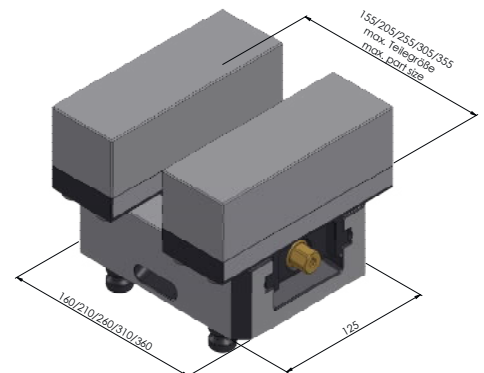
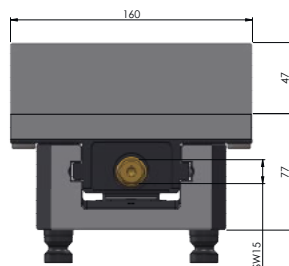
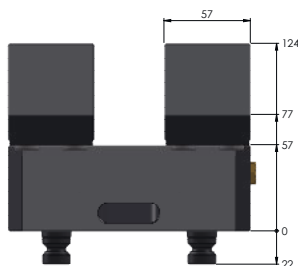

Profilo 77 / 125 center base jaws and spindles

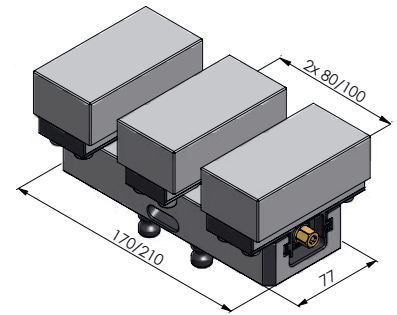
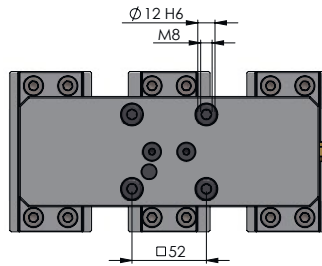

CENTER BASE JAW 112 × 46 MM + SPINDLE FOR CENTERING VISE 77

ITEM NO.	SPINDLE LENGTH (+ \varnothing)	FOR CENTERING VISE	WEIGHT	COMPARABLE FORMER VERSION
49080-TG77	175 mm (\varnothing 16 mm)	40160-77	0.8 kg	49080-TG
49120-TG77	215 mm (\varnothing 16 mm)	40200-77	0.9 kg	49120-TG

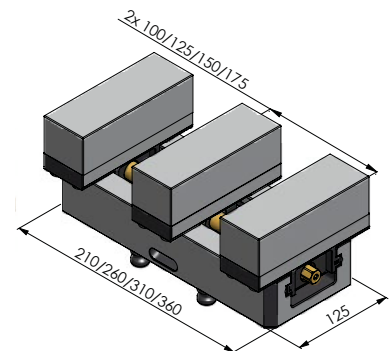
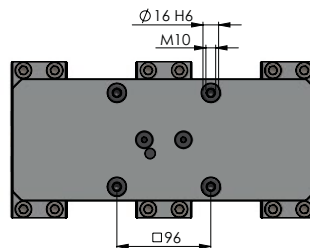
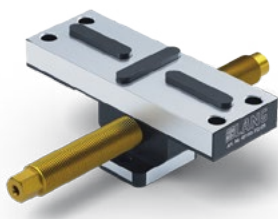

CENTER BASE JAW 160 × 57 MM + SPINDLE FOR CENTERING VISE 125

ITEM NO.	SPINDLE LENGTH (+ \varnothing)	FOR CENTERING VISE	WEIGHT	COMPARABLE FORMER VERSION
49100-TG125	214 mm (\varnothing 20 mm)	40205-125	2.2 kg	49100-TG
49150-TG125	264 mm (\varnothing 20 mm)	40255-125	2.3 kg	49150-TG
49200-TG125	314 mm (\varnothing 20 mm)	40305-125	2.4 kg	49200-TG
49250-TG125	364 mm (\varnothing 20 mm)	40355-125	2.5 kg	49250-TG



LANG

1258

- e2
- e6
- e10
- e14
- e18

1258

70 60 50 40 30 20 10 0 10 20 30 40 50 60 70

1258

LANG

Vario•Tec

Art. Nr. 42097-77

Max. 60Nm

22518

Quick•Point®
Art. Nr. 45160

30Nm

LANG

Vario·Tec

clamping jaws with support
and end stop system

The Vario·Tec pin jaw technology offers a reliable and repeatable end stop and support option for clamping pre-machined components. Its pins make both parallels and external workpiece end stops obsolete. With ingenious simplicity, the clamping situation can be changed by pressing in the pins and reset using compressed air. The Vario·Tec technology is available as a retro-fittable pair of jaws for the 5-axis vise.

Primary area of application:

- **Smooth clamping via friction**
- **Cuboid components**
- **2nd clamping, rear side machining**

Benefits:

- **High flexibility thanks to variable clamping depths**
- **High repeat accuracy when inserting the component and process-reliable clamping**
- **Ideal accessibility as no external workpiece end stops are needed**

Vario-Tec 77 clamping jaws

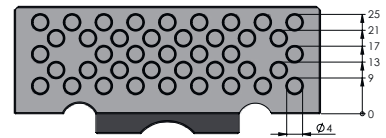
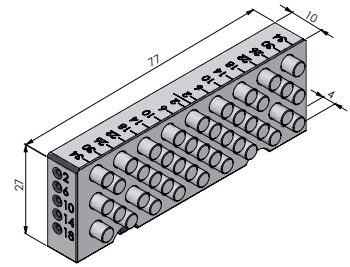

VARIO-TEC 77 CLAMPING JAWS

ITEM NO.	UNIT	WEIGHT	COMPARABLE FORMER VERSION
42018-77	2 pin jaws + 2 carrier jaws	1.2 kg	42077

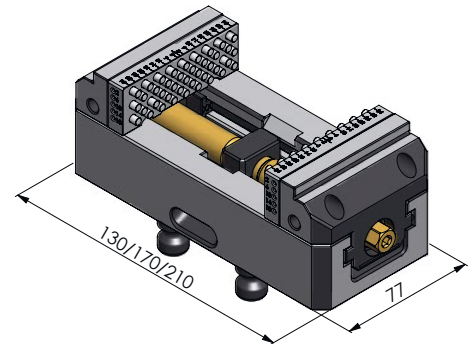
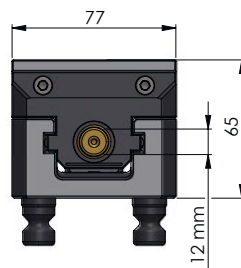
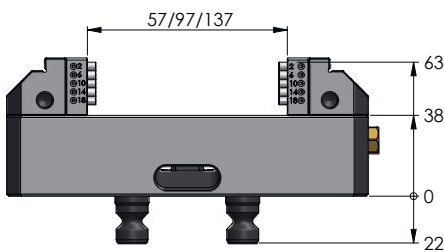

Pins not needed are simply pushed back by hand. The remaining pins act as a support and end stop system.



The pins can be blown out row by row using compressed air. Since the clamping jaws are completely closed at the front, chip clogging can be ruled out.



Resting a workpiece on only two pins ensures great freedom to machine until close to the edge of the workpiece and inner surfaces of the clamping pin jaws.

Vario-Tec 125 clamping jaws

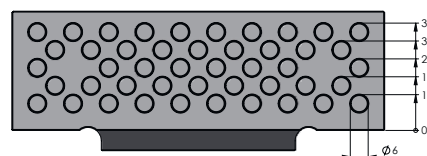
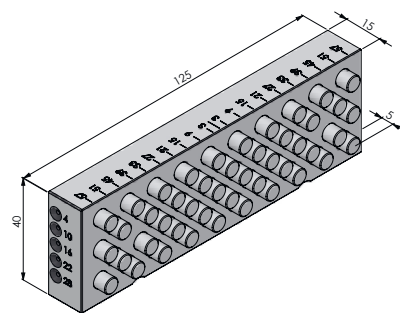
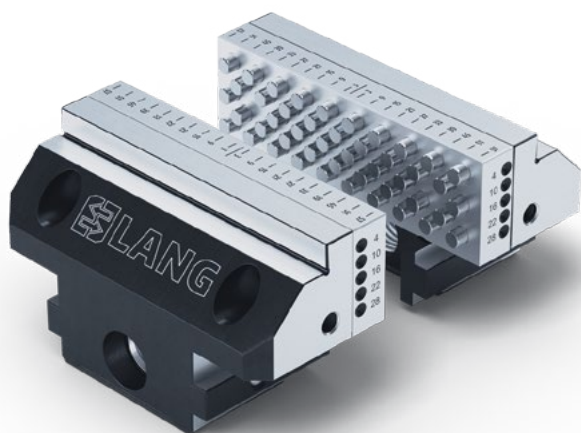

VARIO-TEC 125 CLAMPING JAWS

ITEM NO.	UNIT	WEIGHT	COMPARABLE FORMER VERSION
42018-125	2 pin jaws + 2 carrier jaws	4.6 kg	42125

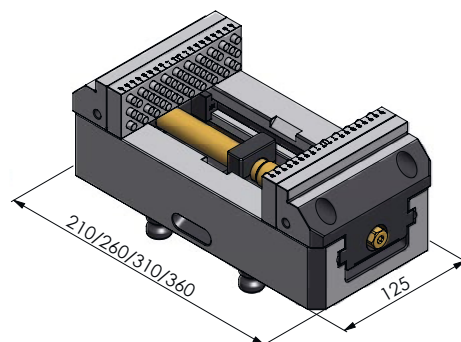
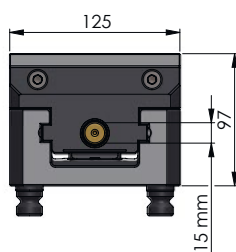
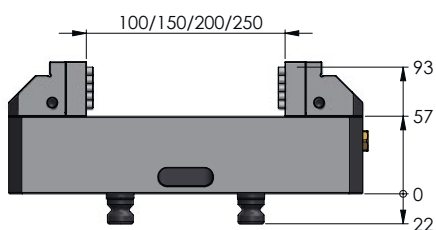

VARIO-TEC ACCESSORIES



ITEM NO.	DESCRIPTION	QTY
20000	Spare pins Ø 4 mm for Vario-Tec 77	5 pcs.
20001	Spare pins Ø 6 mm for Vario-Tec 125	5 pcs.
200009	O-rings Ø 2 × 1,5 mm for Vario-Tec 77 spare pins	100 pcs.
200010	O-rings Ø 3,5 × 2 mm for Vario-Tec 125 spare pins	100 pcs.
20004	Compressed air gun	1 pc.



Vasto-Clamp®
Art. Nr. 59616
2254

Max. 30Nm

LANG

LANG 2116
Quick-Point®
5-Achs-Erhöhung
Art. Nr. 45487

LANG

LANG

LANG

LANG

LANG

PATENT PENDING

Vasto-Clamp

6-jaw chuck

The versatile Vasto-Clamp chuck is a true all-rounder in the milling of round material up to Ø 190 mm. It can be used both as a 3- and 6-jaw chuck and therefore delivers outstanding milling results both for heavy machining of blanks and for sensitive components in the second clamping operation. With its innovative quick-change jaw system, the clamping jaws can be attached by hand in just a few seconds without tools. The integrated zero point adaptation also ensures fast set-up speed, time savings and precise positioning.

Primary area of application:

- **Clamping of cylindrical components via gripping jaws**
- **Smooth clamping of cylindrical components via friction**
- **1st clamping operation, raw part machining**
- **2nd clamping, rear side machining**

Benefits:

- **Enormous adaptability to a wide range of clamping situations**
- **High set-up time savings thanks to quick jaw change**
- **Can be used directly in automation without additional pallets**

Vasto·Clamp

Clamping jaws:

- hard gripping jaws for clamping cylindrical blanks
- soft top jaws for clamping deformation-sensitive components in the second clamping operation

6-jaw chuck:

- made of robust, case-hardened steel
- innovative click system for quick jaw change
- can be used as a 3- and 6-jaw chuck
- outer and inner diameter clamping
- integrated zero point interface
- equipped with automation interface
- chip and coolant drain
- centering accuracy ± 0.04 mm



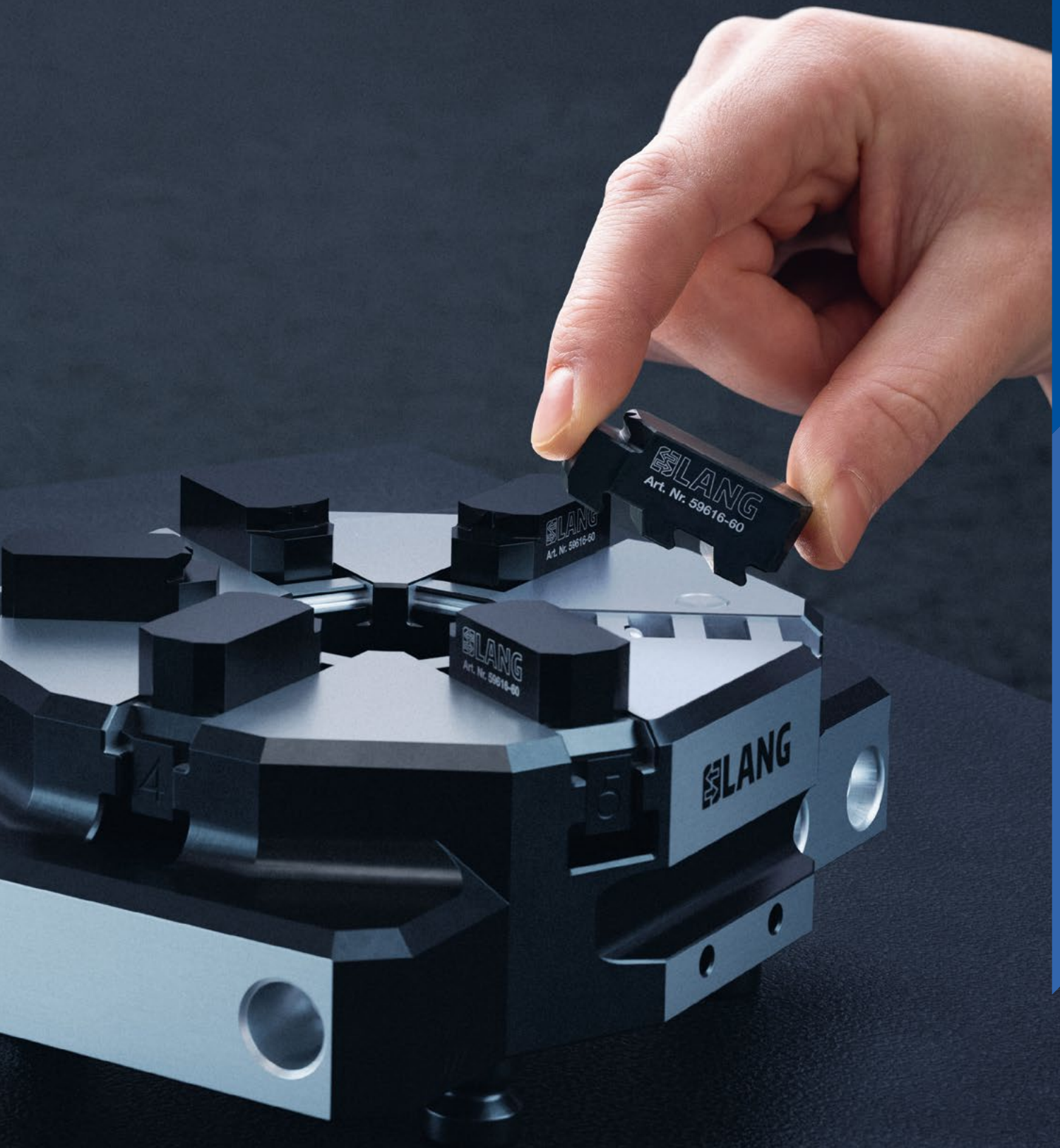

Vasto-Clamp 6-jaw chuck



VASTO-CLAMP 6-JAW CHUCK

ITEM NO.	DIMENSIONS	CLAMPING RANGE	WEIGHT
59616	210 × 155 × 57 mm	10 – 160 mm	9.6 kg

Includes: Base jaws for outer diameter clamping, hexagonal insert with drive square 1/4", size 8 mm

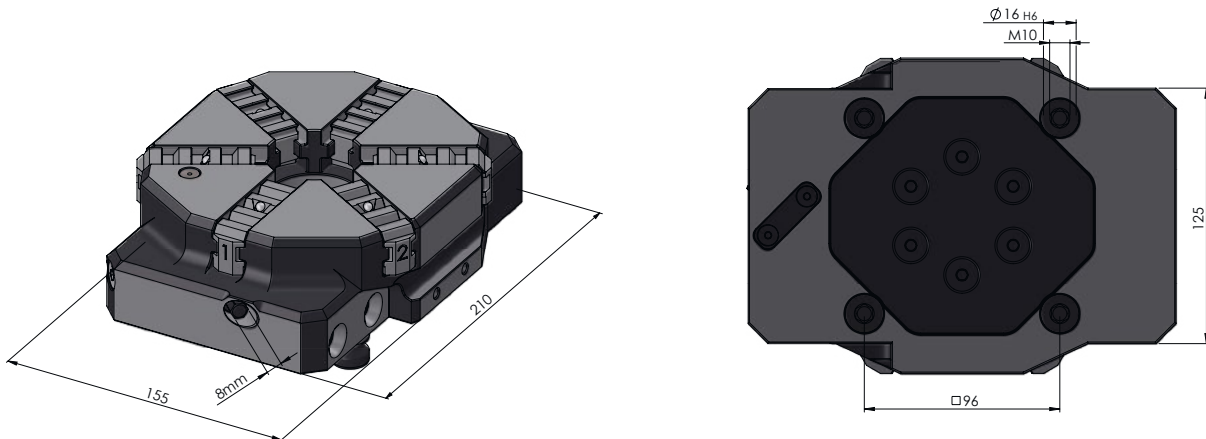

Vasto·Clamp base jaws for inner diameter clamping



VASTO·CLAMP BASE JAWS FOR INNER DIAMETER CLAMPING

ITEM NO.	MATERIAL	FOR	QTY
59616-30	Steel (16MnCr5)	59616-70 to 59616-73	6 pcs.

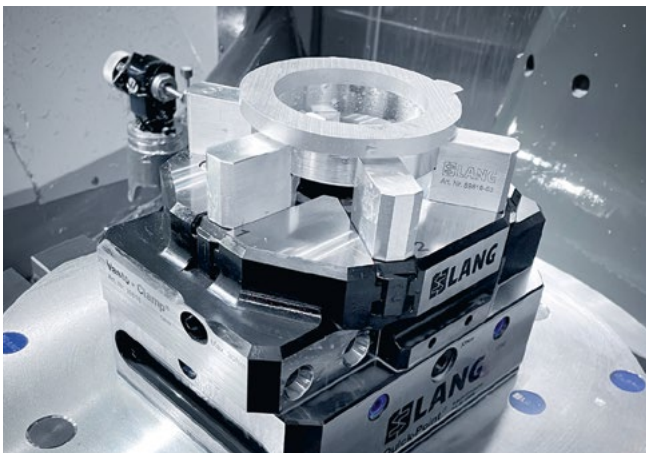

EL-Bauteile Handelsgesellschaft mbH

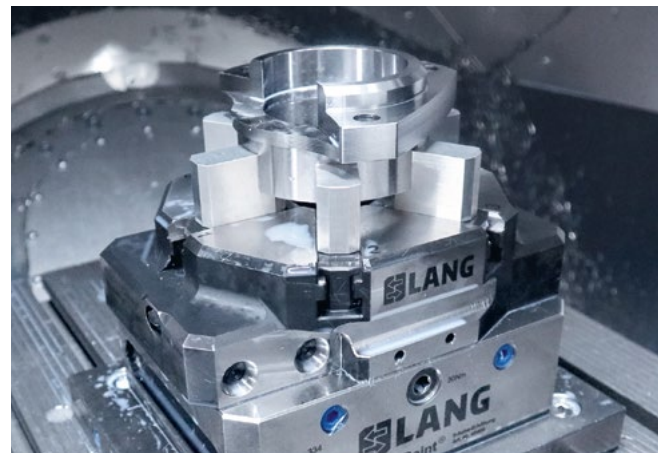

CNC-Technik ORTLIEB GmbH & Co. KG

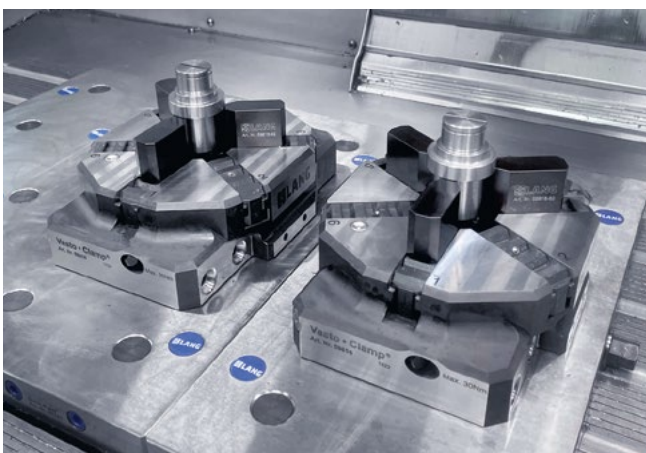

Wild-CNC-Technik



Vasto-Clamp gripping and top jaws for outer diameter clamping

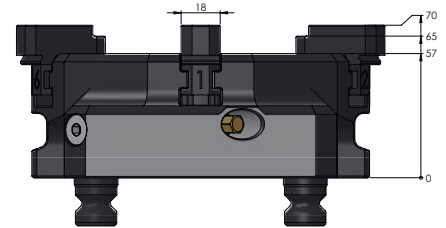
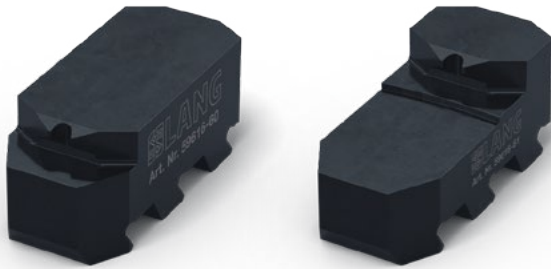

VASTO-CLAMP GRIPPING JAWS, HARDENED

ITEM NO.	MATERIAL	CLAMPING RANGE	QTY
59616-60	Steel (16MnCr5)	30 - 120 mm	6 pcs.
59616-61	Steel (16MnCr5)	75 - 160 mm	6 pcs.

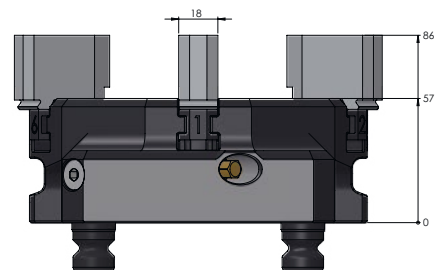
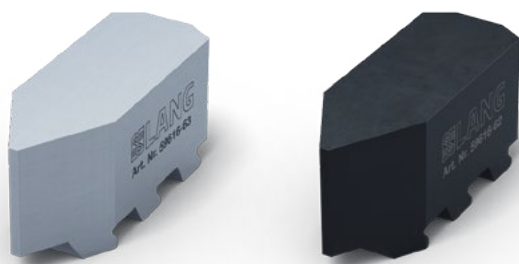

VASTO-CLAMP TOP JAWS, SOFT

ITEM NO.	MATERIAL	CLAMPING RANGE	QTY
59616-62	Steel (16MnCr5)	10 - 160 mm	6 pcs.
59616-63	Aluminium (F50)	10 - 160 mm	6 pcs.

Vasto·Clamp gripping and top jaws for inner diameter clamping

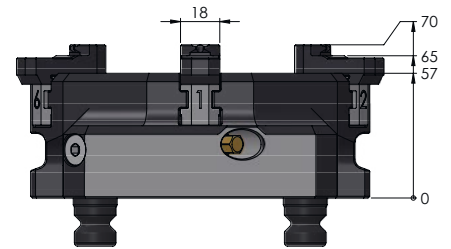

VASTO-CLAMP GRIPPING JAWS, HARDENED

ITEM NO.	MATERIAL	CLAMPING RANGE	QTY
59616-70	Steel (16MnCr5)	50 – 145 mm	6 pcs.
59616-71	Steel (16MnCr5)	90 – 185 mm	6 pcs.

Can only be used in combination with base jaws for inner diameter clamping (Item No. 59616-30).

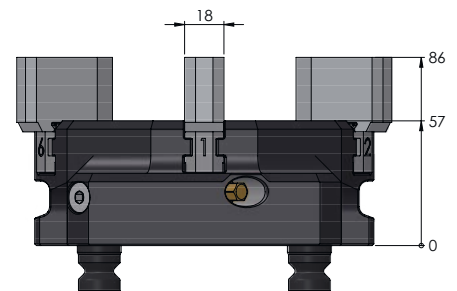
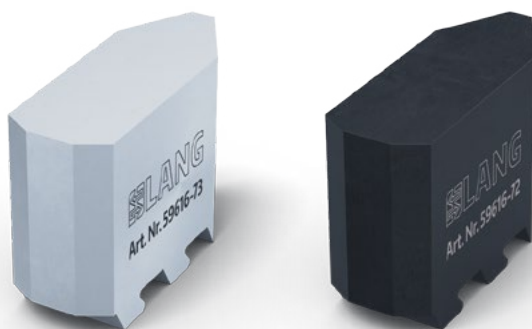

VASTO-CLAMP TOP JAWS, SOFT

ITEM NO.	MATERIAL	CLAMPING RANGE	QTY
59616-72	Steel (16MnCr5)	10 – 190 mm	6 pcs.
59616-73	Aluminium (F50)	10 – 190 mm	6 pcs.

Can only be used in combination with base jaws for inner diameter clamping (Item No. 59616-30).



Preci·Point

collet chuck

The Preci·Point collet chuck is designed for use in milling operations to clamp round material with a diameter of Ø 3 mm to Ø 34 mm. Using standardized collets of type ER 32 and ER 50 which are already available in many workshops, allows the Preci·Point to be used at no additional investment. Its slim design ensures excellent accessibility to the clamped material. A major advantage is the integrated zero point adaptation, which enables a fast and precise set-up process

Primary area of application:

- **Clamping of round material in the diameter range from Ø 3 mm to Ø 34 mm**

Benefits:

- **High set-up time savings thanks to integrated zero point adaptation in the collet chuck**
- **Compact, slim design for ideal accessibility**
- **Cost-saving potential thanks to the use of standard (often already existing) collets**

Preci·Point

Collet:

- The collet chuck is suitable for standard collets of the type:
 - ER 32 – clamping ranges Ø 3 mm to Ø 20 mm
 - ER 50 – clamping ranges Ø 6 mm to Ø 34 mm

Collet chuck:

- made of case-hardened steel
- compact, handy design
- including through-hole
- M6 threaded hole for workpiece endstop
- integrated zero point interface



Preci-Point collet chuck

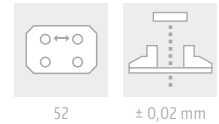
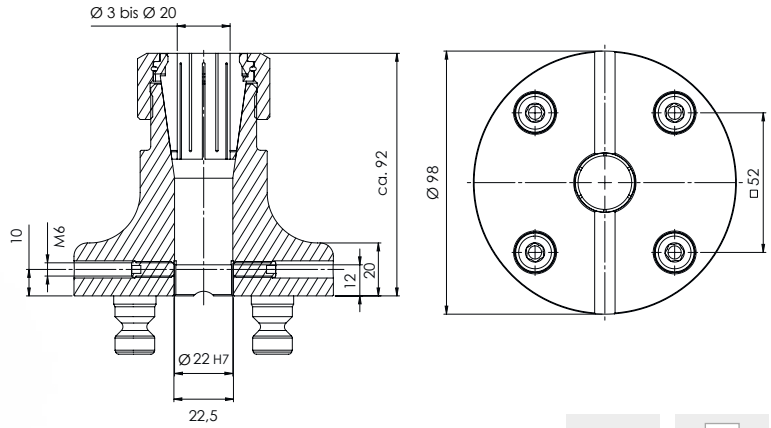

PRECI-POINT COLLET CHUCK FOR ER 32

ITEM NO.	DIMENSIONS	CLAMPING RANGE	WEIGHT
41032	$\varnothing 98 \times 92 \text{ mm}$	$\varnothing 3 - 20 \text{ mm}$	1.9 kg

Includes: 4 Quick-Point® 52 clamping studs $\varnothing 16 \text{ mm}$, screw cap.

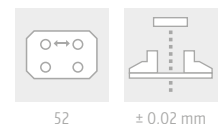
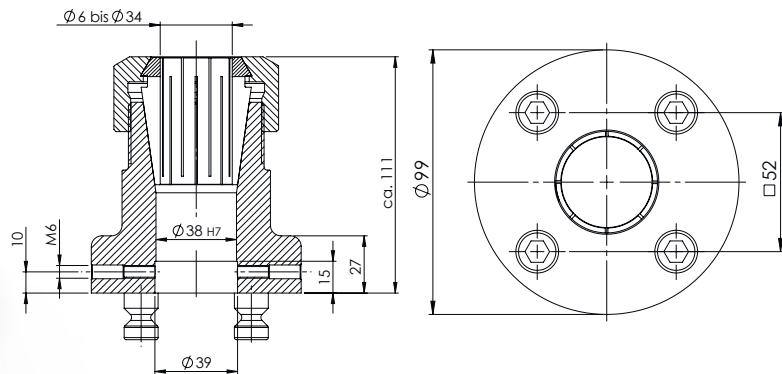

PRECI-POINT COLLET CHUCK FOR ER 50

ITEM NO.	DIMENSIONS	CLAMPING RANGE	WEIGHT
41052	$\varnothing 99 \times 111 \text{ mm}$	$\varnothing 6 - 34 \text{ mm}$	3.0 kg

Includes: 4 Quick-Point® 52 clamping studs $\varnothing 16 \text{ mm}$, screw cap.



PRECI-POINT CLAMPING WRENCH

ITEM NO.	FOR PRECI-POINT
41032-03	ER 32
41052-03	ER 50

Applications

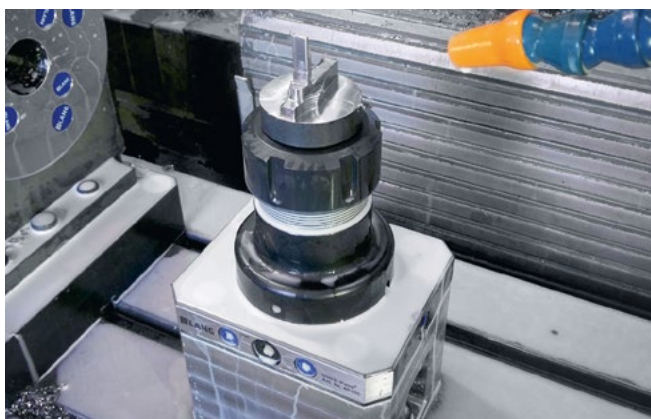

Ratiotechnik Milde GmbH



Berndl Michael & Zellner Julian GbR

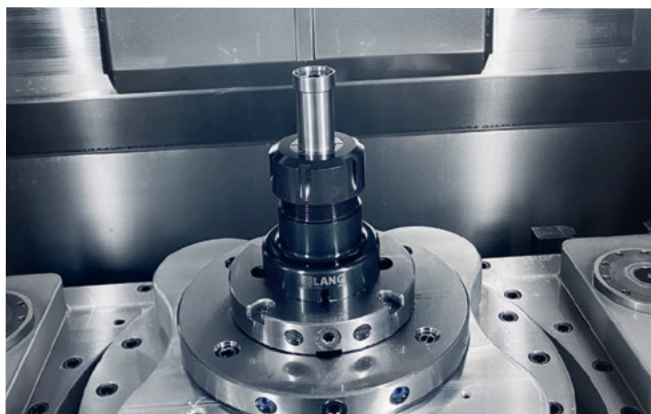

Dengler CNC-Technik





LANG

ULTRA
Makro-Grip

1030
Art. Nr. 81022

LANG

LANG



PATENTED

Makro·Grip® Ultra

clamping system for large parts and plates

Makro·Grip® Ultra is something like the Swiss army knife among LANG Technik's clamping systems. From small workpieces up to a clamping range of around 800 mm, the modular clamping system covers all sizes and component shapes. The strengths of the clamping system become fully apparent when machining plates. Both raw material and pre-machined components can be held with the versatile clamping system. Its simple handling and uncomplicated, cost-effective expandability make Makro·Grip® Ultra an attractive clamping solution, even for larger and heavier components.

Primary area of application:

- **Form-fit clamping via holding serration**
- **Smooth clamping via friction**
- **Cuboid, cylindrical and pre-machined parts**
- **1st clamping operation, raw part machining**
- **2nd clamping, rear side machining**

Benefits:

- **Absolute adaptability to any component shape and size**
- **Cost-effective expansion of the clamping system**
- **User-friendly, ergonomic set-up process thanks to light weights**

Makro-Grip® Ultra

Clamping jaws:

- reversible jaws milled from solid material
- Makro-Grip® clamping technology (form-fit clamping)
- with holding serration on both sides
- 3 mm and 5 mm clamping depth
- threaded caps for quick adjustment of the clamping range
- support jaw in the clamping system's center
- also: clamping jaws with Avanti technology for contour clamping
- single-part or multiple clamping

Base body:

- made of case-hardened steel
- modular, expandable design thanks to individual base elements
- standard system lengths 410 mm, 610 mm, 810 mm
- threaded spindle in three different lengths
- scaling and snap-in function for jaw positioning
- integrated zero point interface





ZERO POINT CLAMPING

WORKHOLDING



Modularity

The modularity and small number of components, as well as the consistent Quick-Point® 96 zero point grid allow to change the clamping setup immediately. Adding base bodies to increase the clamping range, a complete exchange of base bodies to alter the system height and changing jaw types can be done in a few simple steps without special tools.

Easy setting and cleaning

Just as quickly as it is set up, Makro-Grip® Ultra can be disassembled. Clamping jaws and spindles are removed easily which simplifies cleaning and maintenance after and in between machining processes. Clamping tasks that are performed with other fixtures are possible even without having to remove the Makro-Grip® Ultra system. Accessibility still remains and the risk of swarf clogging is low.





Quick jaw adjustment

By removing the threaded cap with a magnetic handle the position of the clamping jaws can be changed in no time without actuating the spindle. Despite their high accuracy of fit the clamping jaws glide smoothly over the guide surface. The threaded cap is kept in place by two extremely resilient hexagon screws (5 mm) which are opened/locked with half a turn.

Scale and snap-in function

For a quick adjustment into the desired position the clamping jaws feature an integrated snap-in function as an orientation aid where the operator feel resistance every 48 mm. Each base body also has a scale which provides a visual aid when positioning the clamping jaws.



Raw part clamping with serrated Makro-Grip® Ultra jaws

The Makro-Grip® stamping and workholding technology, which has been tried and tested for years, also shows its unique advantages in the clamping of large parts. Moulds, plates and all kinds of components from 40 to 810 mm in length and beyond are pre-stamped and then held by form-fit in the Makro-Grip® clamping jaws at only 3 or 5 mm clamping depth. The workpiece is held reliably with the highest holding forces at relatively low actuation torque, which leads to precise results, especially for deformation-sensitive and flat material.

Clamping plates across several Makro-Grip® Ultra units

Not only nearly unlimited in clamping range, but also highly adaptable and modular. Makro-Grip® Ultra can be assembled flexibly using a variety of clamping jaws, base bodies and spindles. The modularity and high centering accuracy of the Makro-Grip® Ultra system, coupled with the precision and flexibility of the Quick-Point® zero point clamping system, guarantee ideal clamping of long parts and plates.

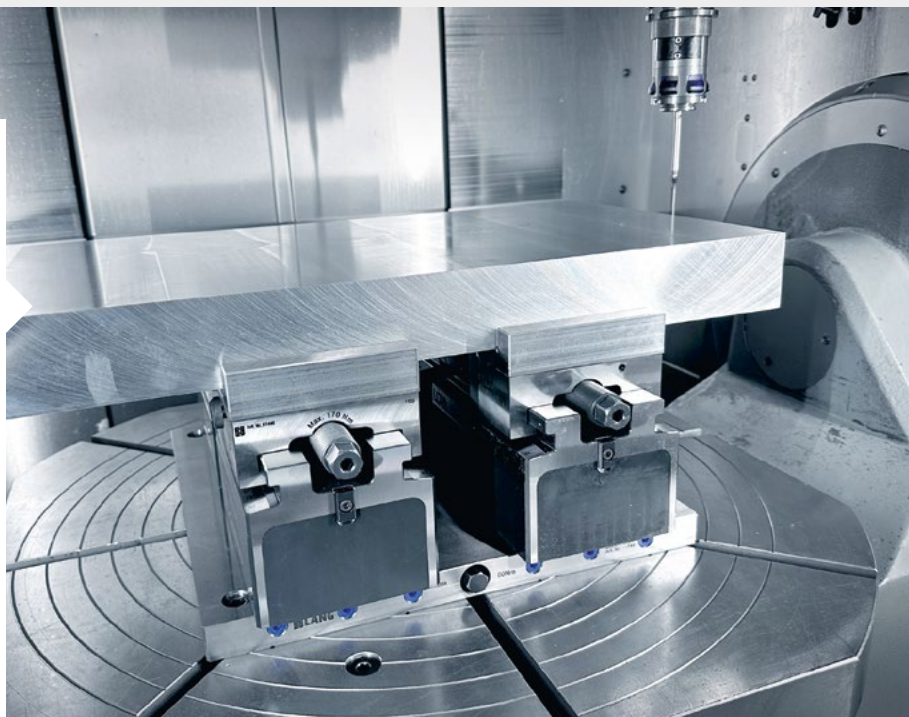

SAW-Technologie GmbH



2nd operation using contour jaws

Even with geometrically unshaped components, Makro-Grip® Ultra offers a simple but efficient solution: Since the jaws are independently adjustable towards the center, asymmetrical clamping configurations can be realised quickly and easily. This reduces set-up for the second operation to a minimum. The quick and precise adjustment of the jaws is ensured by a removable threaded cap and a scale on the base body.

Increased stability through center support

The serrated Makro-Grip® clamping jaws have an additional clamping step on the outside, which enables workpieces to be fixed securely and smoothly by means of friction clamping. For further stabilization in the center, there is a mounted base jaw on which the workpiece rests. This increases stability and reduces potential vibrations during the machining process. Special support jaws are available to the user for this purpose, or the workpiece can be positioned directly on the dovetail guide of the base jaw, as shown in the picture.

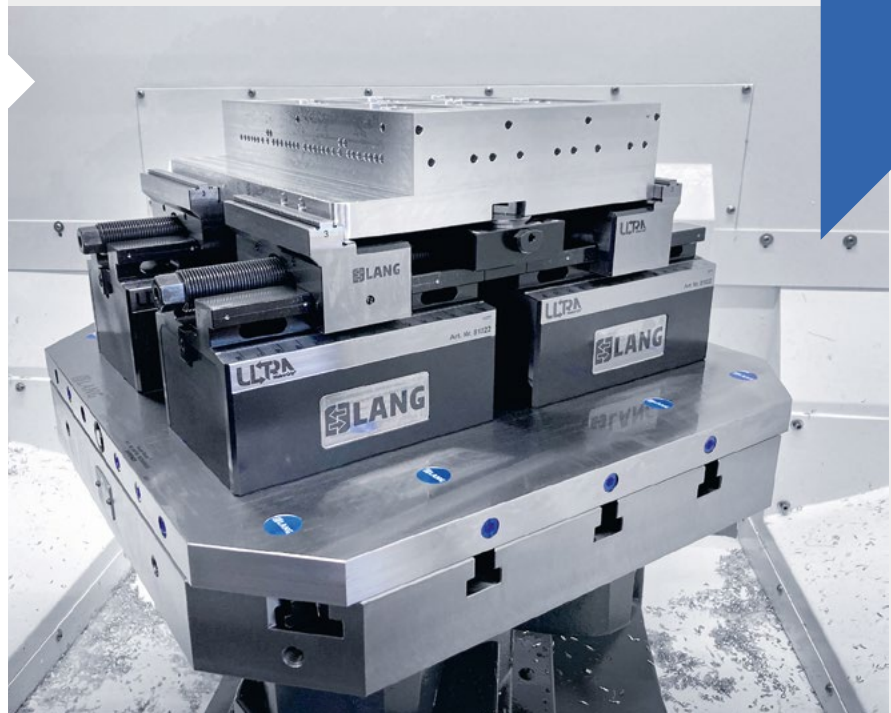

Uhlmann Pac-Systeme GmbH & Co. KG

Overview of the base set system heights with mounted clamping jaws

Base-Set

System height "S"



+ Clamping Jaw type
81483



89 mm
45 mm
0 mm
27 mm



+ Clamping Jaw type
81485



89 mm
45 mm
0 mm
27 mm



+ Clamping Jaw type
81440 + 81450

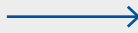

102 mm
45 mm
0 mm
27 mm



+ Clamping Jaw type
81440 + 44259-46



116 mm
70 mm
45 mm
0 mm
27 mm



+ Clamping Jaw type
81440 + 44259-76



146 mm
70 mm
45 mm
0 mm
27 mm

System height "M"

System height "L"



Makro·Grip® Ultra base set

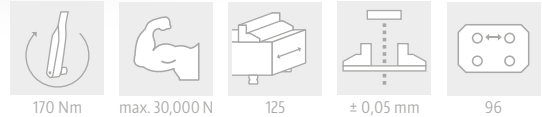

MAKRO·GRIP® ULTRA BASE SET

ITEM NO.	DESCRIPTION	HEIGHT	SPINDLE LENGTH	CLAMPING RANGE	WEIGHT
81400	Base Set 410 S	45 mm	441 mm	40 – 410 mm	12.8 kg
81415	Base Set 410 M	109 mm	441 mm	40 – 410 mm	26.0 kg
81423	Base Set 410 L	189 mm	441 mm	40 – 410 mm	43.2 kg
81600	Base Set 610 S	45 mm	617 mm	40 – 610 mm	19.1 kg
81615	Base Set 610 M	109 mm	617 mm	40 – 610 mm	40.1 kg
81623	Base Set 610 L	189 mm	617 mm	40 – 610 mm	66.9 kg
81800	Base Set 810 S	45 mm	825 mm	40 – 810 mm	25.3 kg
81815	Base Set 810 M	109 mm	825 mm	40 – 810 mm	51.7 kg
81823	Base Set 810 L	189 mm	825 mm	40 – 810 mm	85.7 kg

The model shown has the item no. 81415.

A base set consists of the base body and the following components:



1 × spindle unit
Item No. 81004 / 81006 / 81008



2 × centering plates
Item No. 81010



Quick·Point® clamping studs
Item No. 45570



1 × Quick·Point® cover plug remover
Item No. 45000-30



1 × Wrench internal hexagon size 5 mm
Item No. 45505



1 × Wrench external hexagon size 19 mm
Item No. 45519

Additionally included in the base sets 610 and 810:



2 × connection plates
Item No. 81015

Clamping jaws for base sets

Depending on requirements, either clamping jaws with the Makro-Grip® serration or base jaws with the Avanti technology can be used on the Makro-Grip® Ultra Base Set. Various types of top jaws are also available for the base jaws, which can be found on page 201. Both clamping and base jaws each require a threaded cap with which they are secured on the threaded spindle.

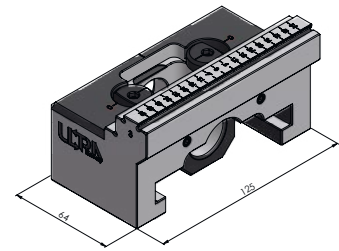
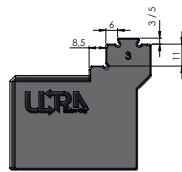

MAKRO-GRIP® ULTRA 125, SERRATED CLAMPING JAW, STEEL (HARDENED)

ITEM NO.	CLAMPING DEPTH	CLAMPING BY	WEIGHT
81483	3 mm	form-fit	2.2 kg
81485	5 mm	form-fit	2.2 kg

Selling unit: 1 piece. For each clamping unit 2 pieces are required.
The specified weight relates to 1 piece.

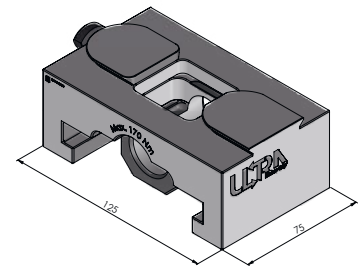
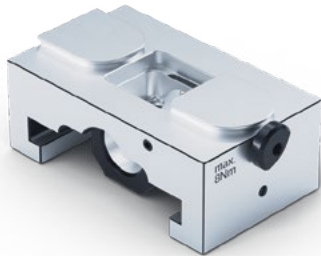

BASE JAW AVANTI 125, STEEL (HARDENED)

ITEM NO.	APPLICATION	WEIGHT
81440	As a base for regular Avanti top jaws and Avanti top jaws with plain clamping step	2.2 kg

Selling unit: 1 piece. For each clamping unit 2 pieces are required.
The specified weight relates to 1 piece. Suitable top jaws can be found on page 201.



THREADED CAP

ITEM NO.	DESCRIPTION	WEIGHT	QTY
81080	Threaded cap, right	0.2 kg	1 piece
81090	Threaded cap, left	0.2 kg	1 piece

For each clamping unit 1 left and 1 right threaded cap is required.

Makro-Grip® Ultra base plates

If the Makro-Grip® Ultra is to be permanently attached to the machine table, the clamping system can also be used without zero point plates. For this purpose, base plates made of non-hardened steel are available, which are attached to the Makro-Grip® Ultra base sets from below and firmly mounted on the machine table. Fastening in the grooves of a machine table allows flexible positioning in the x-direction in order to adjust the distance to a neighboring clamping unit.



MAKRO-GRIP® ULTRA BASE PLATE 410

Tip: Can also be used for other LANG vises with base body width 125 mm or zero point spacing 96 mm!

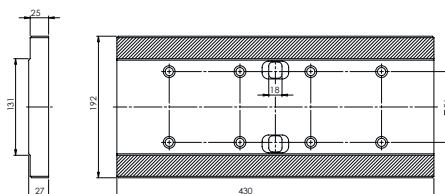

ITEM NO.	FOR BASE SETS	DIMENSIONS	WEIGHT
81411	81400, 81415, 81423	430 × 192 × 27 mm	17.1 kg

Scope of delivery: 1 × base plate, 8 × bushings, 8 × cylinder head screws M 10 × 30.



MAKRO-GRIP® ULTRA BASE PLATE 610

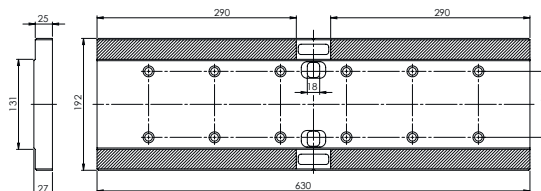

ITEM NO.	FOR BASE SETS	DIMENSIONS	WEIGHT
81611	81600, 81615, 81623	630 × 192 × 27 mm	25.0 kg

Scope of delivery: 2 × base plates, 1 × connection Set, 12 × bushings, 12 × cylinder head screws M 10 × 30.



MAKRO-GRIP® ULTRA BASE PLATE 810

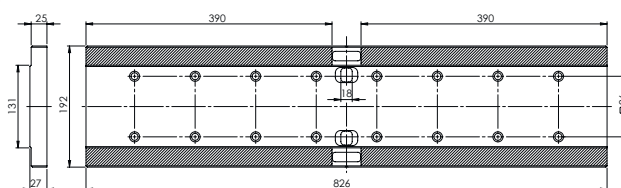

ITEM NO.	FOR BASE SETS	DIMENSIONS	WEIGHT
81811	81800, 81815, 81823	826 × 192 × 27 mm	32.9 kg

Scope of delivery: 2 × base plates, 1 × connection Set, 16 × bushings, 16 × cylinder head screws M 10 × 30.

Top jaws for Makro·Grip® Ultra base jaws

The top jaws shown are used in combination with the base jaws (item no. 81440) on page 199. They are used for smooth clamping of cubic components, of profiles and molds (single or multiple in each case).

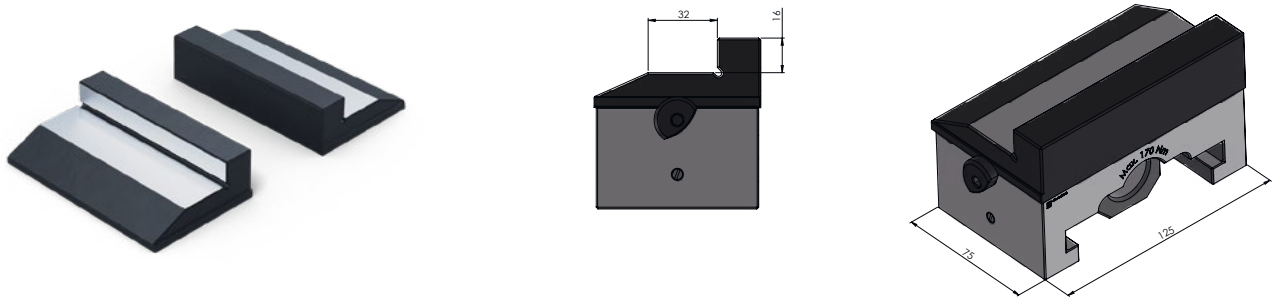

AVANTI 125 TOP JAW WITH PLAIN CLAMPING STEP, STEEL (HARDENED)

ITEM NO.	CLAMPING DEPTH	CLAMPING BY	WEIGHT
81450	16 mm	friction	2.4 kg

Selling unit: 1 pair. The specified weight relates to 1 pair.

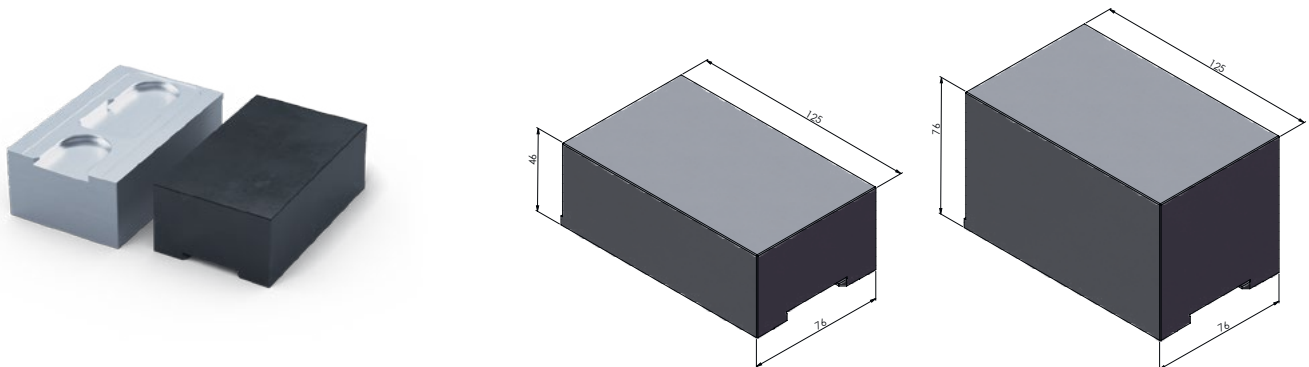

AVANTI 125 TOP JAW (SOFT)

ITEM NO.	MATERIAL	HEIGHT / MAX. CONTOUR DEPTH	WEIGHT
44258-46	Steel (16MnCr5)	46 mm / 39 mm	3.3 kg
44258-76	Steel (16MnCr5)	76 mm / 69 mm	5.5 kg
44259-46	Aluminium (F50)	46 mm / 39 mm	1.2 kg
44259-76	Aluminium (F50)	76 mm / 69 mm	2.0 kg

Selling unit: 1 piece. The specified weight relates to 1 piece.

Note: This type of top jaw is the common version for the Avanti vise.

Clamping and support options for the center

The center base jaw 125 type Avanti is used in combination with a support jaw as an additional support to reduce possible vibrations in the machining process and also as a basis for the center top jaw Avanti 125, as well as conventional Avanti top jaws. For form-fit multiple clamping, the Makro-Grip® 125 center jaw with serration is used.

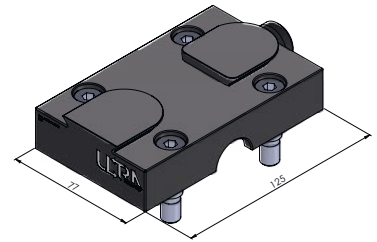

CENTER BASE JAW AVANTI 125, STEEL (HARDENED)

ITEM NO.	APPLICATION	WEIGHT
81440-TG	As a base for support jaws or Avanti top jaws	1.8 kg

Selling unit: 1 piece. The specified weight relates to 1 piece.

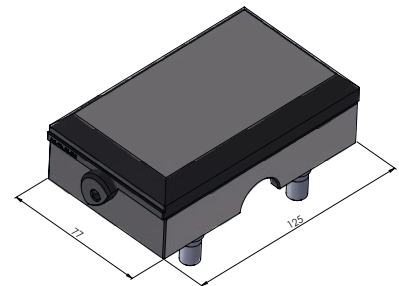
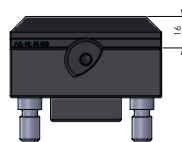
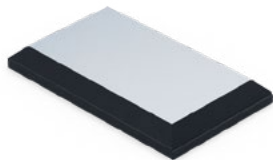

SUPPORT JAW, STEEL (SOFT)

ITEM NO.	FOR	APPLICATION	WEIGHT
81403	81483 / 81450	Single-part clamping by form-fit / friction	1.0 kg
81405	81485	Single-part clamping by form-fit / friction	0.9 kg

Selling unit: 1 piece. The specified weight relates to 1 piece.

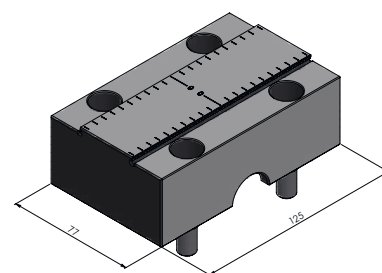
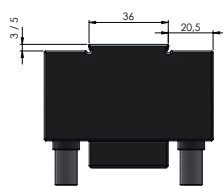
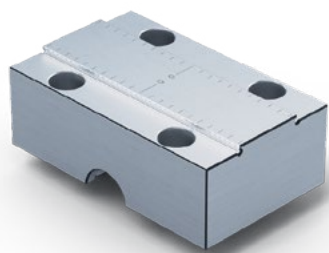

MAKRO-GRIP® ULTRA 125 SERRATED CENTER JAW, STEEL (HARDENED)

ITEM NO.	CLAMPING DEPTH	APPLICATION	WEIGHT
81483-TG	3 mm	Multiple clamping by form-fit	2.3 kg
81485-TG	5 mm	Multiple clamping by form-fit	2.3 kg

Selling unit: 1 piece. The specified weight relates to 1 piece.

The Center Jaw is screwed directly onto the base body and, depending on the variant, used with the Makro-Grip® clamping jaw with serration (item no. 81483 or 81485).

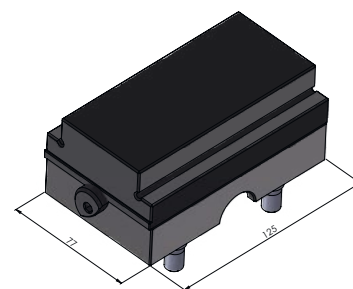
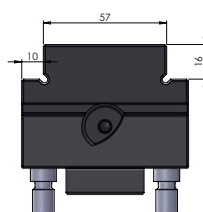

CENTER TOP JAW AVANTI 125 WITH PLAIN CLAMPING STEP, STEEL (HARDENED)

ITEM NO.	CLAMPING DEPTH	APPLICATION	WEIGHT
81450-TG	16 mm	Multiple clamping by friction	1.9 kg

Selling unit: 1 piece. The specified weight relates to 1 piece.

To be used in combination with the center base jaw 125 type Avanti (item no. 81440-TG).



Note: For multiple clamping with mounted center (base) jaw, it is necessary to replace the centering plates installed as standard in the base set with compensating centering plates (item no. 81040). Information on this can be found on p. 198.

Makro-Grip® Ultra **base body**

An individual base body is needed especially when an existing base set is to be expanded. For instance, if you want to go from a clamping range of 410 mm to 610 mm / 810 mm or beyond. With an individual base body Quick-Point® clamping studs are included (4 pcs. for long base bodies, 2 pcs. for short base bodies). Also included are a slot nut and the respective scaling. For stringing together individual base bodies, connection plates are required which can be found on page 206.



SHORT BASE, HEIGHT "S"

ITEM NO.	HEIGHT	LENGTH	WEIGHT
81011	45 mm	96 mm	2.5 kg



SHORT BASE, HEIGHT "M"

ITEM NO.	HEIGHT	LENGTH	WEIGHT
81012	109 mm	96 mm	6.5 kg



SHORT BASE, HEIGHT "L"

ITEM NO.	HEIGHT	LENGTH	WEIGHT
81013	189 mm	96 mm	11.4 kg

**LONG BASE, HEIGHT "S"**

ITEM NO.	HEIGHT	LENGTH	WEIGHT
81021	45 mm	192 mm	5.2 kg

**LONG BASE, HEIGHT "M"**

ITEM NO.	HEIGHT	LENGTH	WEIGHT
81022	109 mm	192 mm	11.5 kg

**LONG BASE, HEIGHT "L"**

ITEM NO.	HEIGHT	LENGTH	WEIGHT
81023	189 mm	192 mm	21.1 kg

Makro·Grip® Ultra individual components



SPINDLE

ITEM NO.	DESCRIPTION	LENGTH	WEIGHT
81004	Spindle unit 410	441 mm	1.7 kg
81006	Spindle unit 610	617 mm	2.4 kg
81008	Spindle unit 810	825 mm	3.1 kg

The spindle (M 26 × 2) comes in three different lengths and is equally used for single-part and multiple clamping. For clamping ranges beyond 810 mm the spindle can be ordered as a customized solution in a longer version. The actuation torque is 170 Nm.



CENTERING PLATE

ITEM NO.	APPLICATION	QTY
81010	Single-part clamping, concentric	1 pc.
81040	Multiple clamping, compensating	1 pc.

For each clamping unit 2 centering plates of the same kind are required. They are mounted to the inner ends of the base bodies and ensure an accurate positioning of the spindle. Two different versions are available for single-part and multiple clamping. The centering plate for multiple clamping has a recess which allows to clamp workpieces with a 4 mm variance in length.



CONNECTION PLATE

ITEM NO.	DESCRIPTION	QTY
81015	Connection plate	1 pc.

Connection plates are already included in delivery of base sets. They are used for stringing together base bodies.



PLASTIC COVERS

ITEM NO.	DESCRIPTION	QTY
81500	Plastic covers for base bodies	20 pcs.

To cover the bores on the upper guide surface of the base body, if center jaws are not mounted.



WRENCHES

ITEM NO.	FOR	WRENCH SIZE
45505	Internal hexagon	5 mm
45519	External hexagon	19 mm

Wrenches for the initial clamping setting (external hexagon) and actuation of the threaded caps' screws (internal hexagon).



HYDRO·SUP HEXAGON WRENCH

ITEM NO.	LENGTH	WRENCH SIZE
45512	230 mm	12 mm

For actuation of the Hydro-Sup screw jack.



HEXAGON SOCKET

ITEM NO.	SQUARE DRIVE	WRENCH SIZE
45511	1/2"	19 mm

Hexagon socket for commercial torque wrenches.



QUICK·POINT® COVER PLUG REMOVER

ITEM NO.	DESCRIPTION
45000-30	Cover Plug Remover

Comfortable magnetic handle for removing threaded caps from the clamping jaws and steel plugs from the Quick-Point® plates.

Makro·Grip® Ultra mechanical support

The mechanical support is suitable for the system height "S" of the Makro·Grip® Ultra clamping system and is installed in the center of the system. Thanks to its pendulum support, it provides additional support in the center of the system for the clamped workpiece and prevents deflection and vibrations when machining plates or thin workpieces.



NEW

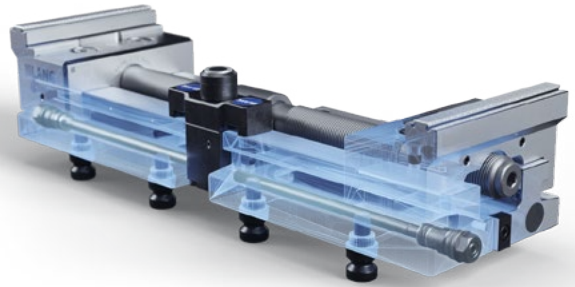

MAKRO·GRIP® ULTRA MECHANICAL SUPPORT

ITEM NO.	DESCRIPTION	FOR	WEIGHT
82586	mechanical support	System height "S"	0.7 kg

Includes: 2 pendulums, 3 operating rods in different lengths, clamping screw size 15.

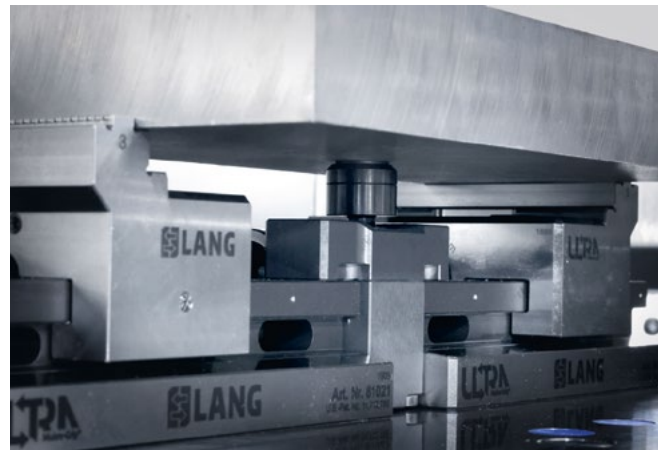
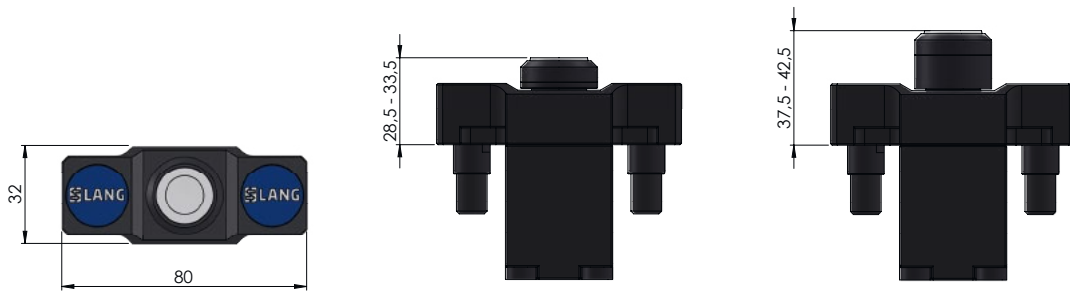

The operating rods are actuated via hexagon socket. This allows the support height of the mechanical support to be adjusted from a minimum of 28.5 mm to a maximum of 42.5 mm.

Makro·Grip® Ultra Hydro·Sup screw jack

The hydraulic screw jack Hydro·Sup with pendulum support is used to reduce vibration during the machining of protruding components. With its integrated clamping stud, it is clamped like a conventional vise in a zero point plate.



HYDRO·SUP SCREW JACK

ITEM NO.	DESCRIPTION	RESTING HEIGHT	WEIGHT
81586	Hydro·Sup hydraulic screw jack	85 – 89 mm	2.8 kg
81515	Spacer for system height "M"	148 – 152 mm	2.9 kg
81523	Spacer for system height "L"	228 – 232 mm	6.6 kg

The suitable socket wrench for operating Hydro·Sup can be found on page 207. Please note: The hydraulic screw jack is not included with the two spacers. It must always be ordered separately.

Resting height

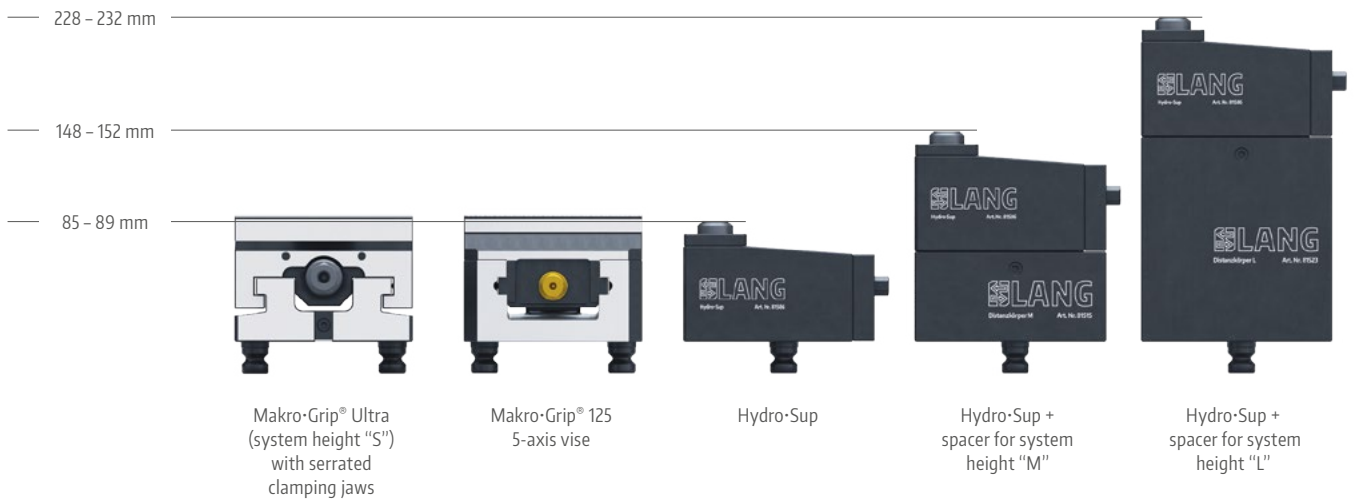

With a height of 86 mm, Hydro·Sup matches the support height of Ultra's system size "S". By using spacers, the overall height of the

system heights "M" and "L" can be achieved. In addition, Hydro·Sup can also be used with regular Makro·Grip® 125 5-axis vises.



Spare parts for former vise versions

On this double page you find all spare parts for older vises (versions until September 2018)



5-AXIS VISE

SPARE JAWS

Makro-Grip® 46	48046-4620	Spare Jaws Makro-Grip® 46
Makro-Grip® 77	47077-20	Spare Jaws Makro-Grip® 77
	47085-20	Spare Jaws Makro-Grip® 77, for Item No. 47085
Makro-Grip® 125	47125-20	Spare Jaws Makro-Grip® 125



AVANTI

BASE JAWS

44771	Avanti Base Jaws 77
44251	Avanti Base Jaws 125



PROFILO

BASE JAWS

49771	Profilo Base Jaws 77
49251	Profilo Base Jaws 125



CENTER BASE JAWS + SPINDLES

49080-TG	Center Base Jaw 77 + Spindle Ø 16 mm, length 175 mm
49120-TG	Center Base Jaw 77 + Spindle Ø 16 mm, length 215 mm
49100-TG	Center Base Jaw 125 + Spindle Ø 20 mm, length 215 mm
49150-TG	Center Base Jaw 125 + Spindle Ø 20 mm, length 265 mm
49200-TG	Center Base Jaw 125 + Spindle Ø 20 mm, length 315 mm
49250-TG	Center Base Jaw 125 + Spindle Ø 20 mm, length 365 mm



VARIO-TEC

SPARE JAW SETS

42077	Spare Jaw Set 77 (2 pin jaws + 2 carrier jaws)
42125	Spare Jaw Set 125 (2 pin jaws + 2 carrier jaws)

5-AXIS VISE



CENTER PIECES + SPINDLES

Makro-Grip® 46	4046082	Center Piece + Spindle Ø 12 mm, length 82 mm
	4046122	Center Piece + Spindle Ø 12 mm, length 122 mm
	4046162	Center Piece + Spindle Ø 12 mm, length 162 mm
Makro-Grip® 77	4077102	Center Piece + Spindle Ø 16 mm, length 102.5 mm
	4077135	Center Piece + Spindle Ø 16 mm, length 135 mm
	4077175	Center Piece + Spindle Ø 16 mm, length 175 mm
	4077215	Center Piece + Spindle Ø 16 mm, length 215 mm
Makro-Grip® 125	4025165	Center Piece + Spindle Ø 20 mm, length 165 mm
	4025215	Center Piece + Spindle Ø 20 mm, length 215 mm
	4025265	Center Piece + Spindle Ø 20 mm, length 265 mm
	4025315	Center Piece + Spindle Ø 20 mm, length 315 mm
	4025365	Center Piece + Spindle Ø 20 mm, length 365 mm



CENTER JAWS + SPINDLES FOR DUAL CLAMPING

Makro-Grip® 46	47065-TG	Center Jaw + Spindle Ø 12 mm, length 82 mm
	47105-TG	Center Jaw + Spindle Ø 12 mm, length 122 mm
	47145-TG	Center Jaw + Spindle Ø 12 mm, length 162 mm
Makro-Grip® 77	47085-TG17	Center Jaw 17 mm + Spindle Ø 16 mm, length 102.5 mm
	47085-TG27	Center Jaw 27 mm + Spindle Ø 16 mm, length 102.5 mm
	47120-TG17	Center Jaw 17 mm + Spindle Ø 16 mm, length 135 mm
	47120-TG27	Center Jaw 27 mm + Spindle Ø 16 mm, length 135 mm
	47160-TG17	Center Jaw 17 mm + Spindle Ø 16 mm, length 175 mm
	47160-TG27	Center Jaw 27 mm + Spindle Ø 16 mm, length 175 mm
	47200-TG17	Center Jaw 17 mm + Spindle Ø 16 mm, length 215 mm
	47200-TG27	Center Jaw 27 mm + Spindle Ø 16 mm, length 215 mm
Makro-Grip® 125	47155-TG17	Center Jaw 17 mm + Spindle Ø 20 mm, length 165 mm
	47155-TG27	Center Jaw 27 mm + Spindle Ø 20 mm, length 165 mm
	47205-TG17	Center Jaw 17 mm + Spindle Ø 20 mm, length 215 mm
	47205-TG27	Center Jaw 27 mm + Spindle Ø 20 mm, length 215 mm
	47255-TG17	Center Jaw 17 mm + Spindle Ø 20 mm, length 265 mm
	47255-TG27	Center Jaw 27 mm + Spindle Ø 20 mm, length 265 mm
	47305-TG17	Center Jaw 17 mm + Spindle Ø 20 mm, length 315 mm
	47305-TG27	Center Jaw 27 mm + Spindle Ø 20 mm, length 315 mm
	47355-TG17	Center Jaw 17 mm + Spindle Ø 20 mm, length 365 mm
	47355-TG27	Center Jaw 27 mm + Spindle Ø 20 mm, length 365 mm



AUTOMATION

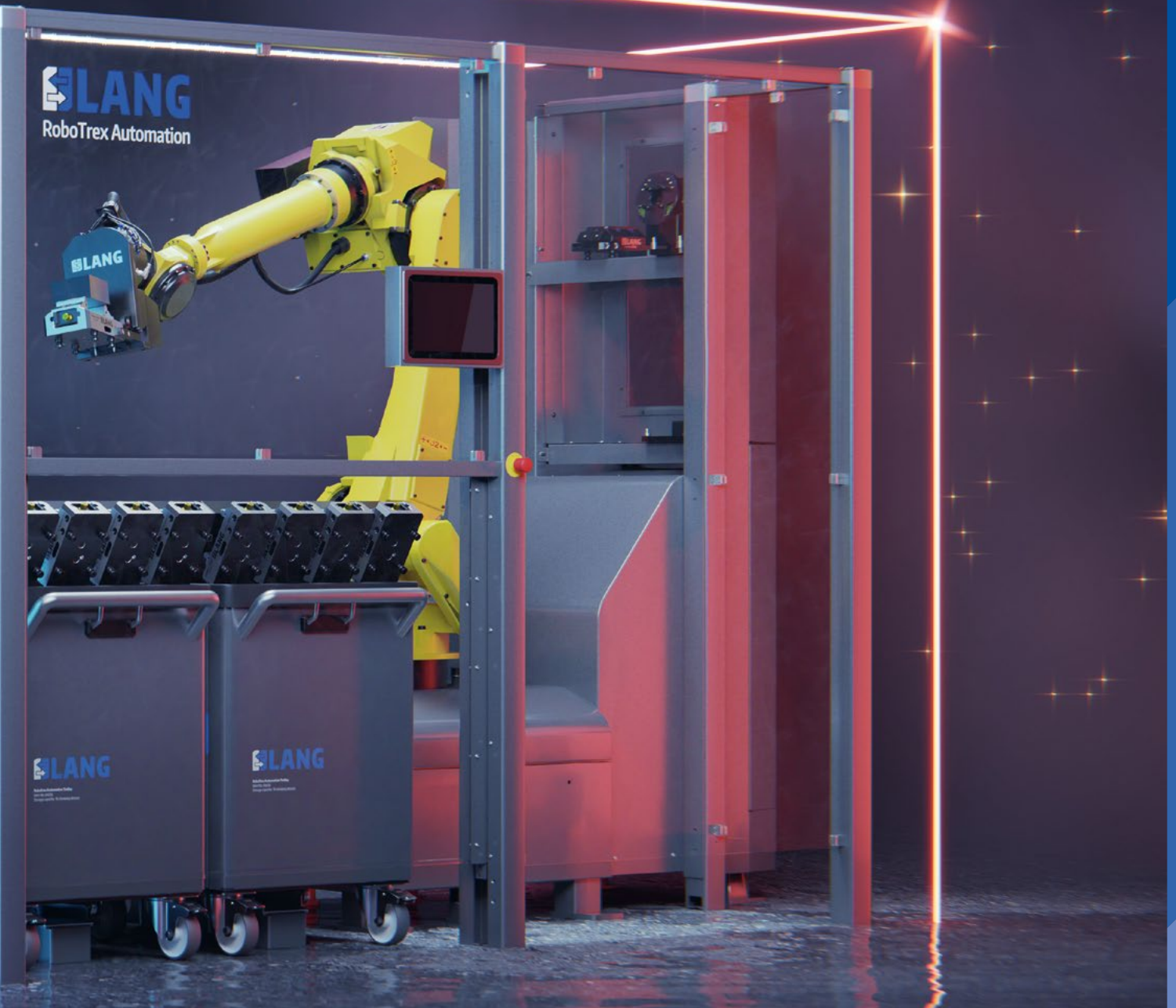

- 216 RoboTrex **automation system**
- 240 RoboTrex Compact **automation system**
- 250 Haubex **automation system**
- 260 Clean·Tec **chip fan**

Automation

Automation systems from LANG Technik are characterized by:

VERSATILITY

USER-FRIENDLINESS

LOW SPACE REQUIREMENTS

WISE HANDLING SYSTEMS WITH INDUSTRIAL ROBOT



RoboTrex Compact

NEW



RoboTrex 96



RoboTrex 52

AUTOMATIC CLEANING OF CNC MACHINE INTERIOR



Clean-Tec
chip fan



Haubex

VICE CARRIER SYSTEM WITH WORKHOLDING HOOD

PART HANDLING SYSTEM WITH AUTOMATIC PRE-STAMPING AND PNEUMATIC VISES



Makro-Grip® Aero
Information available on
lang-technik.de and in a separate
brochure after product launch



COMING 2025





PATENTED

RoboTrex

automation system

RoboTrex is an automation system that can be connected and retrofitted to almost any machine tool. Utilizing automation trolleys as a storage medium for vises, as opposed to pallets, the vises are removed directly by a Fanuc robot and fed to the machine tool. RoboTrex covers all requirements, from single part production to large series. It is flexible, easy to operate and offers an excellent cost-benefit ratio. In addition to a high storage capacity on a small footprint, RoboTrex is particularly impressive due to its set-up time savings when loading and unloading the automation system.

Primary area of application:

- **Automated, unmanned production in milling machining**
- **Single parts to larger series**
- **Vise handling**

Benefits:

- **Can be retrofitted to almost any new or existing machine tool**
- **Extremely simple operation, no robot knowledge required**
- **Minimum time required for setting up and equipping the system**

Simple automation of CNC machines

This gallery shows a fraction of the RoboTrex installations with various machine manufacturers and brands that have been successfully implemented.



DMG MORI / Englert GmbH & Co KG



HERMLE / Stebotec CNC-Zerspanungstechnik GmbH



BROTHER / Koatek A/S



HAAS / Hendrik Michel Zerspanungstechnik GmbH



GROB / Lindauer DORNIER GmbH



FANUC / KOEM Tech-One Co. Ltd.



In addition to the machine tools of the world's most commonly represented manufacturers, the list includes about as many other manufacturers. Please feel free to use the QR code to learn more on our website.



DOOSAN / CNC-Solutions Baden GmbH



OKUMA / R&W Maschinenbau GmbH



KERN / Usiplast Composites



GF / thiem Individual Zerspanung



HURCO / Inopart GmbH



MAZAK

RoboTrex

Automation system:

- two different system sizes: RoboTrex 52 and 96
- available as 2-trolley and 4-trolley version
- automation trolley as a vise storage system (four variants)
- pre-programmed Fanuc industrial robot with six axes
- enclosure with Makrolon windows
- 16 different installation variants
- front and side loading of machine tools
- single-part and series production
- communication with the machine tool via M-function
- operation via touch display
- mechanical or pneumatic control of the zero point clamping system
- no media interface required within the machine tool





ZERO POINT CLAMPING

WORKHOLDING

AUTOMATION

simple. flexible. automation.

RoboTrex is a powerful automation system that can be integrated to almost all machine tools. By retrofitting it uncomplicatedly to existing CNC milling machines or simply equipping it to new machine tools, RoboTrex offers utmost flexibility and efficiency. Since no modification is required from the machine tool manufacturer, this approach logically saves costs and efforts. The quick installation of the automations system results in a short downtime of the machining center, so that your production can be continued smoothly.

Providing all essential automation components from a single

source makes you independent from other manufactures and you can fully rely on RoboTrex. This eliminates unpleasant communication difficulties and ensures a trouble-free process of planning your production line. A significant part of this is due to the ideal balance between the three main components: vises, zero point clamping system and automation. With RoboTrex you not only get a state-of-the-art automaton system, but also a reliable future-proof solution for your production.



 **LANG**
RoboTrex Automation



10 reasons for automating your machine-tool with RoboTrex

- 1 Higher production output**
More output thanks to increased spindle hours and machine utilization
- 2 Production independent of personnel**
Protection against absences due to illness or shortage of skilled workers
- 3 Reduction in production costs**
due to lower hourly machine rates in unmanned production
- 4 Increasing the attractiveness of the workplace**
Facilitation of physical work, expansion of tasks, elimination of shift work
- 5 Better responsiveness**
through flexible organization of production management and adjustment of prioritization
- 6 Faster delivery times**
Shorter lead times thanks to automated, unmanned multi-shift operation
- 7 Greater process reliability**
by minimizing sources of error and using the highest quality technologies
- 8 Ideal utilization of the production area**
Compact design and high storage capacity on a small footprint
- 9 Enormous variety of components**
High coverage of the component spectrum with standardized clamping systems
- 10 High cost efficiency**
Customized, coordinated plug & play complete solution



A closer look: What makes RoboTrex special



COMPLEXITY & OPERATION

We keep it simple!

The simple, intuitive operation of RoboTrex is limited to a few functions that can be learned by anyone in a very short time and for which no specialist personnel are required. Thanks to the already pre-programmed robot, no programming knowledge is required for the operator. Within a few hours, the operator is able to operate the automation system on his own, independently and safely.

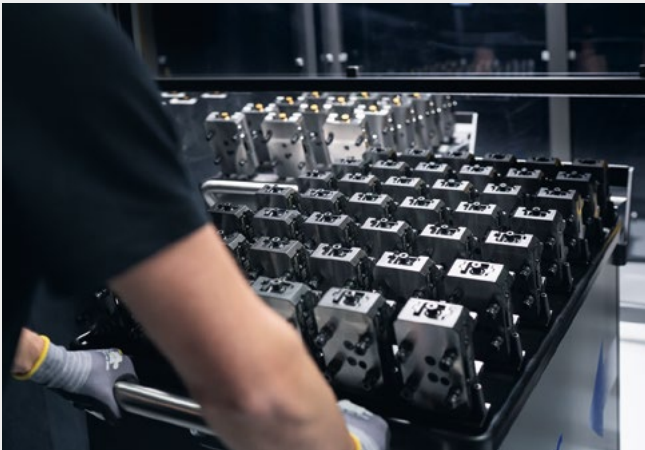

STORAGE CAPACITY & SPACE REQUIREMENTS

We make great use of space!

The patented upright storage of the vises on the automation trolleys is decisive for a high storage capacity – with remarkably low space requirements for the entire system. Another plus: The absence of additional pallets ensures low transport weights, does not generate unnecessary costs and guarantees optimum accessibility during milling.



SET-UP & TROLLEY CHANGE

We are fast!

Offline preparation of the automation trolleys and trolley exchange in seconds ensure a continuous workflow without unnecessary machine tool downtimes. The vises can be re-equipped with new blanks without having to remove them from the trolley. This saves time and energy.



VARIETY OF PARTS

We are flexible!

In addition to batch production with completely identical workpieces on an automation trolley, RoboTrex offers even more options for customizing production management. From deselecting individual clamping device positions or rows to individual part production by assigning an NC program for each clamping device position – there are no limits to a flexible trolley loading.



STORAGE ACCESS

We are in control!

No need to select a specific pallet position or wait until the robot has transported the clamping device to the automation system's loading/unloading station. With RoboTrex, you have instant access to the entire storage. This means that each vise can be removed quickly and easily or the finished workpiece can be checked for a quick quality control.

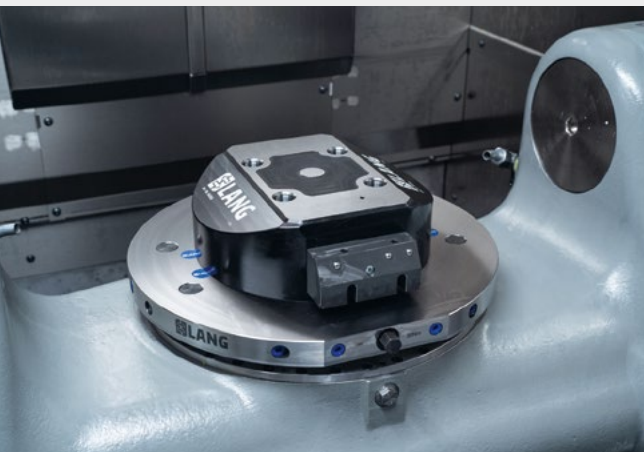

MEDIA INTERFACE

We are independent!

The RoboTrex zero point clamping system can, but does not necessarily have to, be controlled by the machine. This is made possible by the external interface on the robot gripper, which opens the zero point device pneumatically. RoboTrex 52 also offers the option of purely mechanical actuation. Thanks to the external control, RoboTrex presents itself as a universal system that operates independently of the specific conditions inside the machine.

Variety of parts

RoboTrex was designed as a simple, universal automation system that can also be retrofitted to older machining centers that were not actually designed for automated loading. This is realized, among other things, by a communication interface based on a simple signal exchange of acknowledgeable and potential-free M commands. This allows single-variety components to be processed automatically on all trolleys. RoboTrex also offers more flexible pro-

duction management. Individual vise positions can be deselected within the system so that oversized and extra-wide workpieces can be automated on a standard trolley. If the machining center has an extended interface, even different components can be machined in a single automation cycle. Either one component type per trolley, or individual and completely different workpieces on one trolley. The latter usually requires a bus interface on the part of the machine.



Identical parts



One part type per trolley



Single part production (left trolley)

Media feed-through

In order to be able to automatically feed pallets or vises to a machine tool, a clamping system on the machine side is required, which is also opened and closed automatically. Older machines often lack an appropriate media feed-through to actuate zero point clamping systems pneumatically or hydraulically.

Retrofitting is associated with very high costs, if possible at all. An external supply is technically out of the question, especially for 5-axis machines. RoboTrex offers an efficient, albeit simple method of automating machines without media feed-through.

A module integrated in the gripper opens and closes the Quick-Point® zero point clamping system pneumatically or mechanically. A constant supply of compressed air during processing is not necessary.

However, if the machine has a rotary feed-through, the zero point system can be modified so that it is controlled via the machine.

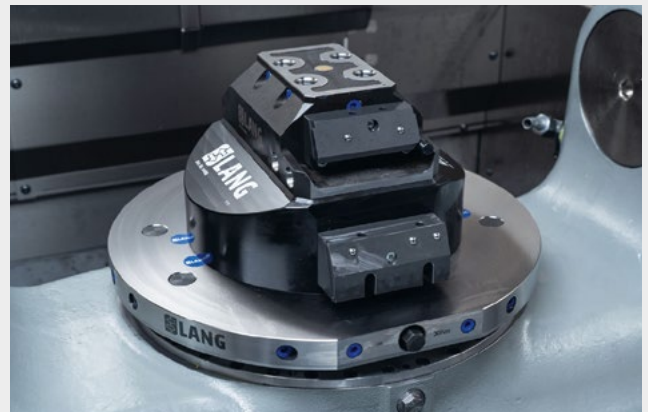



Loading through the machine door



Loading through a side window

Set-up variants

Depending on the design (accessibility to the machine table, arrangement of the tool changer), machining centers are loaded through a side window or through the machine door. Loading from the side should always be preferred, as access to the machine door and therefore further manual operation of the machine is maintained.

However, even if the machine has to be loaded from the front with RoboTrex, this does not rule out conventional operation. An access door is installed through which machine operators can continue to carry out manual tasks on and in the machine tool. It goes without saying that the access door is equipped with appropriate safety mechanisms to ensure safety-compliant automatic operation.

It is not only the machine concept that determines the choice of loading direction; local conditions and space constraints also determine the position of the automation system. Here, up to 16 variable installation options of the RoboTrex system help to find the most suitable variant.

Automation of the machine door / side window

Depending on the loading side, the machine door (front loading) or a side window (side loading) must be opened and closed automatically. This function can normally be purchased as an option on newer machines. These automated doors or windows are controlled via the machine control system. Subsequent retrofitting by the

machine manufacturer can either be very cost-intensive or may even be rejected.

LANG offers the retrofitting of a side window or the automation of the machine door using pneumatic cylinders. In both cases, it is controlled by the robot.



Hin Feinmechanik GmbH



Bärtschi Mechanik GmbH

RoboTrex 52 automation system



Available as a
2- or 4-trolley
version



ROBOTREX 52 AUTOMATION SYSTEM

ITEM NO.	BASIC EQUIPMENT
66000	Complete robotic automation system incl. enclosure and trolley entry system
STORAGE CAPACITY OF TROLLEY	30 / 42 vises
QTY OF TROLLEYS	max. 4 pcs.
TOTAL STORAGE CAPACITY	120 / 168 vises
WORKPIECE DIMENSIONS WITH FULLY EQUIPPED TROLLEY	max. 120 × 120 × 100 mm / max. 120 × 100 × 70 mm
WORKPIECE WEIGHT	max. 15 kg
GRIPPER EXCHANGE INTERFACE	no
ACTUATION OF ZERO POINT SYSTEM	mechanical or pneumatic
FOOTPRINT	from 1.70 × 2.20 m
LOADING	through machine door or side window

RoboTrex 52 automation trolley



ROBOTREX 52, AUTOMATION TROLLEY

ITEM NO.	STORAGE CAPACITY	MAX. PART SIZE (WHEN FULLY LOADED)	WEIGHT
66030	30 vises	120 × 120 × 100 mm	190 kg
66042	42 vises	120 × 100 × 70 mm	195 kg

Maximum load capacity of trolley: 500 kg.

Trolley loading with different part sizes

On the RoboTrex automation trolley, it is possible to store vises in which larger or taller workpieces are clamped. Two options are available for this. Firstly, you can leave vise positions empty on an

automation trolley with a standard configuration. Secondly, it is possible to customize the storage rows, which is determined during the planning phase.



Automation trolley with standard alignment. Here: 14 parts, each measuring 300 × 120 × 70 mm.



Automation trolley with customized alignment. Here: 7 rows of 5 positions for a total of 35 vises with a maximum part size of 70 × 100 × 120 mm.

RoboTrex 52 grippers and zero point clamping systems



Suitable 5-axis vises:



48120-46



48120-77



68120-77

Other clamping jaw variants are also possible.
Please do not hesitate to ask!

GRIPPER 77, MECHANICAL

ITEM NO.	MAX. WORKPIECE WEIGHT	SUITABLE ZERO POINT SYSTEM	WEIGHT
66930	15 kg	66500	2.3 kg

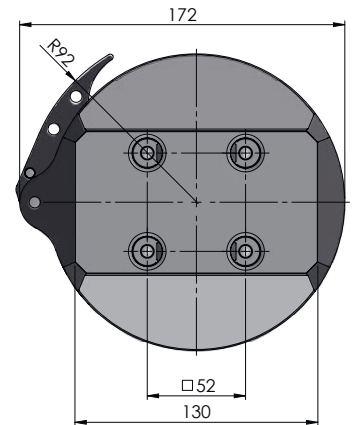
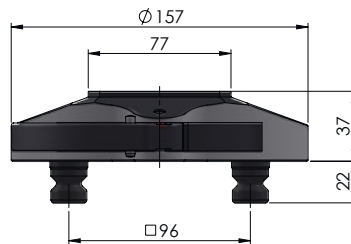

ZERO POINT CLAMPING SYSTEM 52, MECHANICAL

ITEM NO.	AUTOMATION SYSTEM	SUITABLE GRIPPER	WEIGHT
66500	RoboTrex 52	66930	5.2 kg

Includes: Adapter for manual operation + bracket, aluminium handle.
Please note: The zero point clamping system is not included in the scope of delivery of RoboTrex.



NEW VERSION

Suitable 5-axis vises:



48120-46



48120-77



68120-77

Other clamping jaw variants are also possible.
Please do not hesitate to ask!

GRIPPER 77, PNEUMATIC

ITEM NO.	MAX. WORKPIECE WEIGHT	SUITABLE ZERO POINT SYSTEM	WEIGHT
66925	15 kg	66650	2.2 kg



NEW VERSION

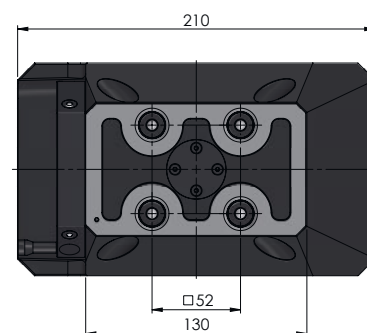
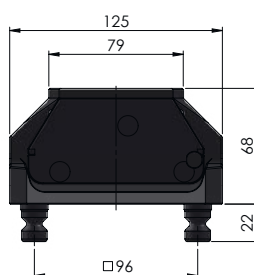

ZERO POINT CLAMPING SYSTEM 52, PNEUMATIC

ITEM NO.	AUTOMATION SYSTEM	SUITABLE GRIPPERS	WEIGHT
66650	RoboTrex Compact, RoboTrex 52 and RoboTrex 96	66925 / 66955 / 62955	7.7 kg

Includes: Adapter for manual operation + bracket, aluminium handle.

Please note: The zero point clamping system is not included in the scope of delivery of RoboTrex.

This product is also shown on pages 236 and 249.

Makro-Grip® 77, Night King



MAKRO-GRIP® 77, NIGHT KING JAW WIDTH 77 MM

ITEM NO.	BASE LENGTH	CLAMPING RANGE	WEIGHT	QTY
68120-77	130 mm	0 - 120 mm	2.9 kg	10 - 30
68120-77	130 mm	0 - 120 mm	2.9 kg	40 - 60
68120-77	130 mm	0 - 120 mm	2.9 kg	70 - 90
68120-77	130 mm	0 - 120 mm	2.9 kg	from 100

Sold as a set of 10.

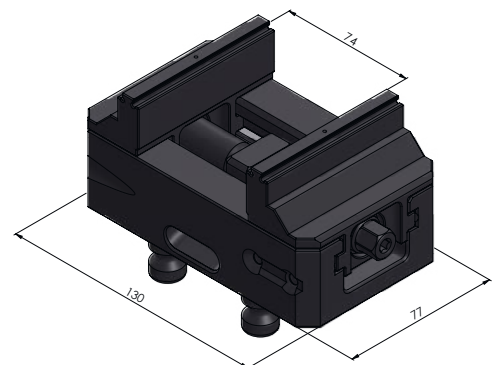
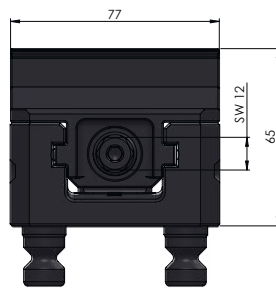
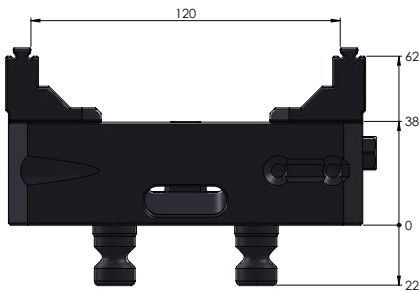

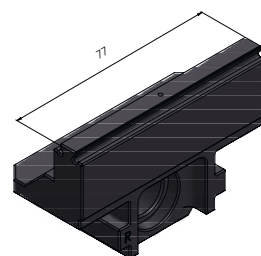
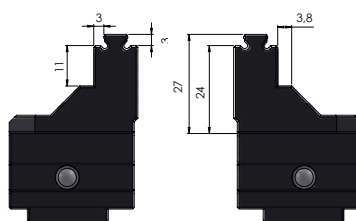

SPARE JAWS FOR MAKRO-GRIP® 77, NIGHT KING

ITEM NO.	FOR	WEIGHT	QTY
68077-7720	regular serration Makro-Grip®	0.8 kg	1 pair
68077-7720 FS	Full serration Makro-Grip® FS	0.8 kg	1 pair

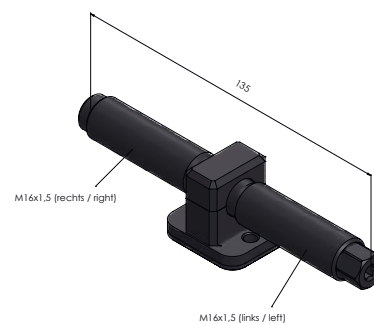

SPINDLE + CENTER PIECE FOR MAKRO-GRIP® NIGHT KING

ITEM NO.	FOR	SPINDLE LENGTH	WEIGHT
6877135	68120-77	135 mm / Ø 16 mm	0.3 kg

Applications

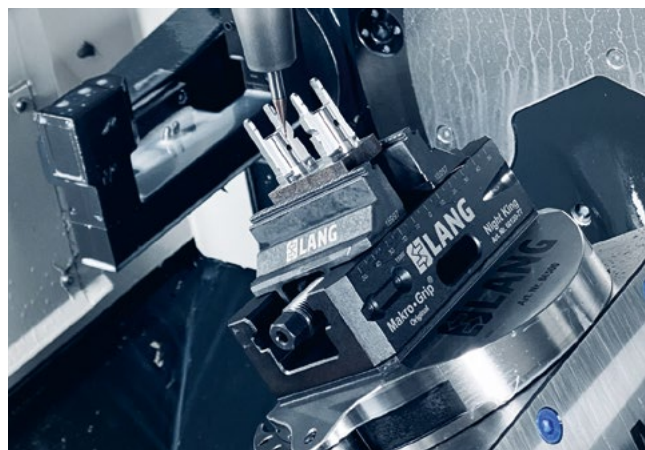

RoboTrex 96 automation system



Available as a
2- or 4-trolley
version



ROBOTREX 96 AUTOMATION SYSTEM

ITEM NO.	BASIC EQUIPMENT
64000	Complete robotic automation system incl. enclosure and trolley entry system
The suitable grippers and automation zero point systems are available separately on pages 236 / 237.	
STORAGE CAPACITY OF TROLLEY	15 / 16 vises
QTY OF TROLLEYS	max. 4 pcs.
TOTAL STORAGE CAPACITY	60 / 64 vises
WORKPIECE DIMENSIONS WITH FULLY EQUIPPED TROLLEY	max. 205 × 205 × 90 mm / max. 205 × 150 × 150 mm
WORKPIECE WEIGHT	max. 25 kg, optionally: max. 45 kg
GRIPPER EXCHANGE INTERFACE	yes
ACTUATION OF ZERO POINT SYSTEM	pneumatic
FOOTPRINT	from 2.00 × 2.70 m
LOADING	through machine door or side window

RoboTrex 96 automation trolley

**DUE TO GRIPPER EXCHANGE
ALSO APPLICABLE**

RoboTrex 52
automation trolley
66030

RoboTrex 52
automation trolley
66042



ROBOTREX 96, AUTOMATION TROLLEY

ITEM NO.	STORAGE CAPACITY	MAX. PART SIZE (WHEN FULLY LOADED)	WEIGHT
64015	15 vises	205 × 205 × 90 mm	185 kg
64016	16 vises	205 × 150 × 150 mm	180 kg

Maximum load capacity of trolley: 500 kg.

Trolley loading with different part sizes

On the RoboTrex automation trolley, it is possible to store vises in which larger or taller workpieces are clamped. Two options are available for this. Firstly, you can leave vise positions empty on an

automation trolley with a standard configuration. Secondly, it is possible to customize the storage rows, which is determined during the planning phase.



Automation trolley with standard alignment. Here 5 parts, each measuring 410 × 205 × 90 mm.

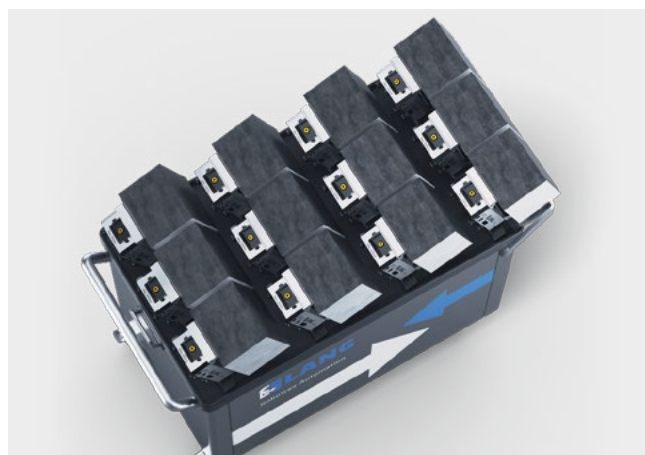

Automation trolley with customized alignment. Here: 4 rows of 3 positions for a total of 12 vises with a maximum part size of 205 × 203 × 150 mm.

RoboTrex 96 grippers and zero point clamping systems



NEW VERSION

Suitable 5-axis vises:



Other clamping jaw variants are also possible.
Please do not hesitate to ask!

GRIPPER 77, PNEUMATIC

ITEM NO.	MAX. WORKPIECE WEIGHT	SUITABLE ZERO POINT SYSTEM	WEIGHT
66955	15 kg	66650	3.7 kg



NEW VERSION

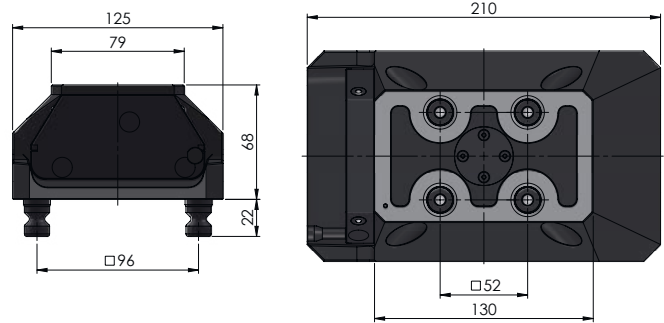

ZERO POINT CLAMPING SYSTEM 77, PNEUMATIC

ITEM NO.	AUTOMATION SYSTEM	SUITABLE GRIPPER	WEIGHT
66650	RoboTrex Compact, RoboTrex 52 and RoboTrex 96	66925 / 66955 / 62955	7.7 kg

Includes: Adapter for manual operation + bracket, aluminium handle.
Please note: The zero point clamping system is not included in the scope of delivery of RoboTrex.
This product is also shown on pages 231 and 249.



NEW VERSION

Suitable clamping devices:



48205-77



48205-125



59616

Other clamping jaw variants are also possible.
Please do not hesitate to ask!

GRIPPER 125, PNEUMATIC

ITEM NO.	MAX. WORKPIECE WEIGHT	SUITABLE ZERO POINT SYSTEM	WEIGHT
64855	25 kg	64855	13.9 kg



NEW VERSION

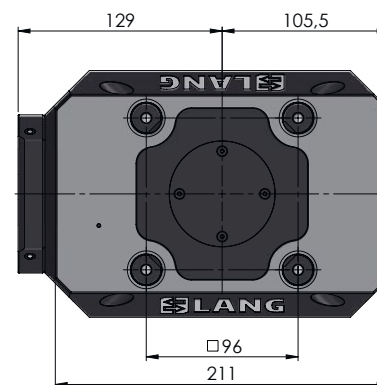
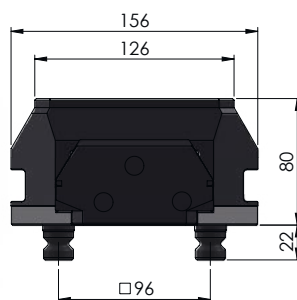

ZERO POINT CLAMPING SYSTEM 125, PNEUMATIC

ITEM NO.	AUTOMATION SYSTEM	SUITABLE GRIPPER	WEIGHT
64550	RoboTrex 96	64855	16.2 kg

Includes: Adapter for manual operation + bracket, aluminium handle.

Please note: The zero point clamping system is not included in the scope of delivery of RoboTrex.

Other components for individual automation solutions



All essential RoboTrex components are also available as individual components in order to be used with conventional automation systems. Whether it's a connection to an existing robotic system, an integration in robot cells or shelf systems or a flexible in-house solution, LANG clamping systems make every automated manufacturing process more efficient.

From the various vise versions and automation trolleys to the automation window, all of these components are listed in the table below. Grippers and zero point devices can be found on the previous pages and are not listed hereafter.

CLAMPING DEVICES:	ITEM NO.
Makro-Grip® 77, 5-axis vise, jaw width 46 mm	48120-46
Makro-Grip® 77, 5-axis vise, jaw width 77 mm	48120-77
Makro-Grip® 77, Night King, jaw width 77 mm	68120-77
Makro-Grip® 125, 5-axis vise, jaw width 77 mm	48205-77
Makro-Grip® 125, 5-axis vise, jaw width 125 mm	48205-125
Vasto-Clamp 6-jaw chuck	59616

In addition, the 40120-46 / 40120-77 and 40205-77 / 40205-125 centering vise bases can be used for automation in combination with the Makro-Grip® FS, Makro-4Grip, Avanti, Profilo and Vario-Tec clamping jaw types.

AUTOMATION TROLLEYS AND POSITIONING BOLTS:	ITEM NO.
RoboTrex 52 automation trolley, 30 vises	66030
RoboTrex 52 automation trolley, 42 vises	66042
Positioning bolt for RoboTrex 52 automation trolley	66087
RoboTrex 96 automation trolley, 15 vises	64015
RoboTrex 96 automation trolley, 16 vises	64016
Positioning bolt for RoboTrex 96 automation trolley	64086
Automation trolley with special alignment	99996

MISCELLANEOUS:	ITEM NO.
Trolley entry system for RoboTrex 52 and 96	66120
Automation window for RoboTrex 52 and 96	66750
Gripper exchange interface	64266

Makro·Grip® mobile storage unit

The mobile storage unit offers a space-saving and flexible option to store up to 60 clamping devices. Clamping devices that are equipped with integrated Quick·Point® clamping studs of system sizes 52 and 96 are placed in the holes on the side surfaces of the mobile storage unit.



MAKRO-GRIP® MOBILE STORAGE UNIT

ITEM NO.	STORAGE CAPACITY	DIMENSIONS	WEIGHT
61060	max. 60 clamping devices	1,400 × 800 × 1,500 mm	154 kg







RoboTrex Compact

automation system

RoboTrex Compact is an automation system that has been specially developed for the unmanned production of small workpieces weighing up to 7 kg. The latest automation solution from LANG Technik is even more compact than the well-known RoboTrex automation system and offers space for up to 100 vises in its storage rack on a footprint of only two square meters. RoboTrex Compact can be retrofitted to almost any machine tool and covers small and medium batch sizes. Thanks to its simple operation, the plug-and-play system requires no specialist personnel.

Primary area of application:

- **Automated, unmanned production**
- **Individual parts up to medium series sizes**
- **Parts up to 7 kg**

Benefits:

- **High storage capacity on a small footprint**
- **Extremely simple operation, no robot knowledge required**
- **More output thanks to increased spindle hours and machine utilization**

RoboTrex Compact

Automation system:

- compact footprint of only two square meters
- 2-sided vise storage rack for up to 100 vises
- pre-programmed Fanuc industrial robot with six axes
- front and side loading of machine tools
- optional swivel unit for front loading
- single-part and series production
- communication with the machine tool via M-function
- operation via touch display
- pneumatic control of the zero point clamping system
- no media interface required within the machine tool





RoboTrex Compact automation system



ROBOTREX COMPACT AUTOMATION SYSTEM

ITEM NO.	DIMENSIONS	MAX. STORAGE CAPACITY
62000	2,000 × 1,050 × 2,000 mm	100 × Makro·Grip® 46 Micro / 50 × Makro·Grip® 77

The matching grippers and automation zero point clamping systems are shown on pages 248 / 249.

Customized color design



Customize the color design of your RoboTrex Compact to match your machine tool!

The corner elements of your RoboTrex Compact can be customized on request at no extra costs.

Manual gripper exchange for different vise sizes



The two different vise sizes, Makro-Grip® 46 Micro and Makro-Grip® 77, can be used by changing the robot gripper. After selecting the size via the operating menu, the robot moves to its change position, which is located directly next to the system's control panel and is easily accessible for the operator. The robot gripper can be changed in just a few seconds. Thanks to the proven Quick-Point® clamping system with clamping studs on the back of the gripper, it can be easily loosened and fixed using a hexagon socket screw.

The two gripper versions and the matching zero point clamping system are shown on pages 248 / 249.

Swivel unit when loading through the machine door

When automating a CNC machine, accessibility plays an important role, especially if loading is done through the machine door. To manually produce parts in between without the automation system, the space directly in front of the CNC machine must remain accessible to the operator.

With a special swivel unit, which has already proven itself in earlier automation solutions from LANG Technik, RoboTrex Compact solves this requirement simply and effectively.

The automation system, which is firmly fixed by a foot and locked in its end position during machining, can be easily swiveled away after the end of machining and release of the lock. This way, the space directly in front of the machine door is completely cleared and made accessible.



Equipping options

Utilizing Makro-Grip® 46 Micro, 5-axis vises

Like RoboTrex, RoboTrex Compact also allows the use of different vise and jaw versions. When using Makro-Grip® 46 Micro, up to 50 vises can be accommodated on each side of the storage rack, for a total of 100 vises for both sides. Instead of raw part clamping, pre-machined parts can also be clamped using the so-called "monobloc" contour jaws (Item No. 47469) on the Makro-Grip® 46 Micro 5-axis vise.

Storage capacity when fully equipped:

100 × Makro-Grip® 46 Micro vises
at a maximum workpiece size of
65 × 50 × 95 mm



Utilizing Makro-Grip® 77, 5-axis vises

The arrangement of the storage rows also allows the use of Makro-Grip® 77 vises. 25 vises can be stored in the storage rack on each side, resulting in a total capacity of 50. This type of vise in particular opens up a wide range of options for operators to use different clamping jaws. Among others, Makro-4Grip clamping jaws can be used to clamp cylindrical blanks, or Avanti for clamping profiled and pre-machined parts. Vario-Tec, with its flexible support and end stop system, is also a possible choice.

Storage capacity when fully equipped:

50 × Makro-Grip® 77 vises
at a maximum workpiece size of
120 × 100 × 80 mm



Flexible assembly with different part sizes

The clamping of wider or higher components is parts by leaving neighboring positions empty or by simply removing a row of racks. This allows operators to tailor their production management to their specific needs. From skipping individual vise positions or rows to single-part production by assigning an NC program for each vise position, RoboTrex Compact can do much more than just pure batch production.



RoboTrex Compact grippers and zero point clamping systems



NEW

Suitable 5-axis vise:



48040-46



Hint: Mounting contour jaws Item No. 47469 to the Makro-Grip® 46 Micro vise allows for clamping pre-machined parts with RoboTrex Compact.

GRIPPER 46 MICRO, PNEUMATIC

ITEM NO.	MAX. WORKPIECE WEIGHT	SUITABLE ZERO POINT SYSTEM	WEIGHT
62900	7 kg	62500	2.6 kg



NEW

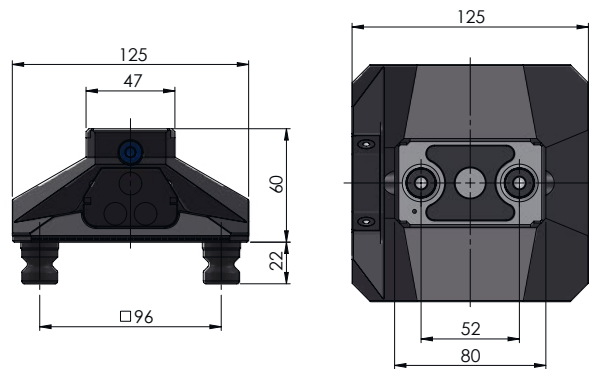

ZERO POINT CLAMPING SYSTEM 52 DUO, PNEUMATIC

ITEM NO.	OPERATION	SUITABLE GRIPPER	WEIGHT
62500	pneumatic	62900	3.5 kg

Includes: Adapter for manual operation + bracket, aluminium handle.
Please note: The zero point clamping system is not included in the scope of delivery of RoboTrex Compact.



NEW

Suitable 5-axis vises:



48120-46



48120-77



68120-77

Other clamping jaw variants are also possible.
Please do not hesitate to ask!

GRIPPER 77, PNEUMATIC

ITEM NO.	MAX. WORKPIECE WEIGHT	SUITABLE ZERO POINT SYSTEM	WEIGHT
62955	7 kg	66650	2.5 kg



NEW VERSION

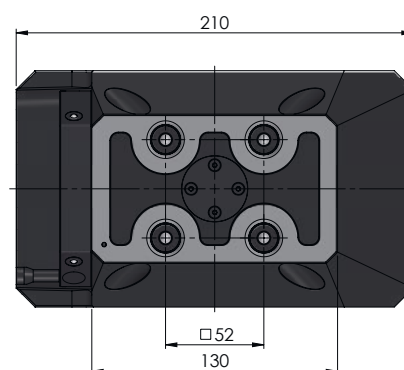
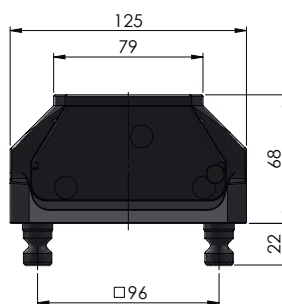

ZERO POINT CLAMPING SYSTEM 52, PNEUMATIC

ITEM NO.	OPERATION	SUITABLE GRIPPERS	WEIGHT
66650	pneumatic	66925 / 66955 / 62955	7.7 kg

Includes: Adapter for manual operation + bracket, aluminium handle.

Please note: The zero point clamping system is not included in the scope of delivery of RoboTrex Compact.

This product is also shown on pages 231 and 236.

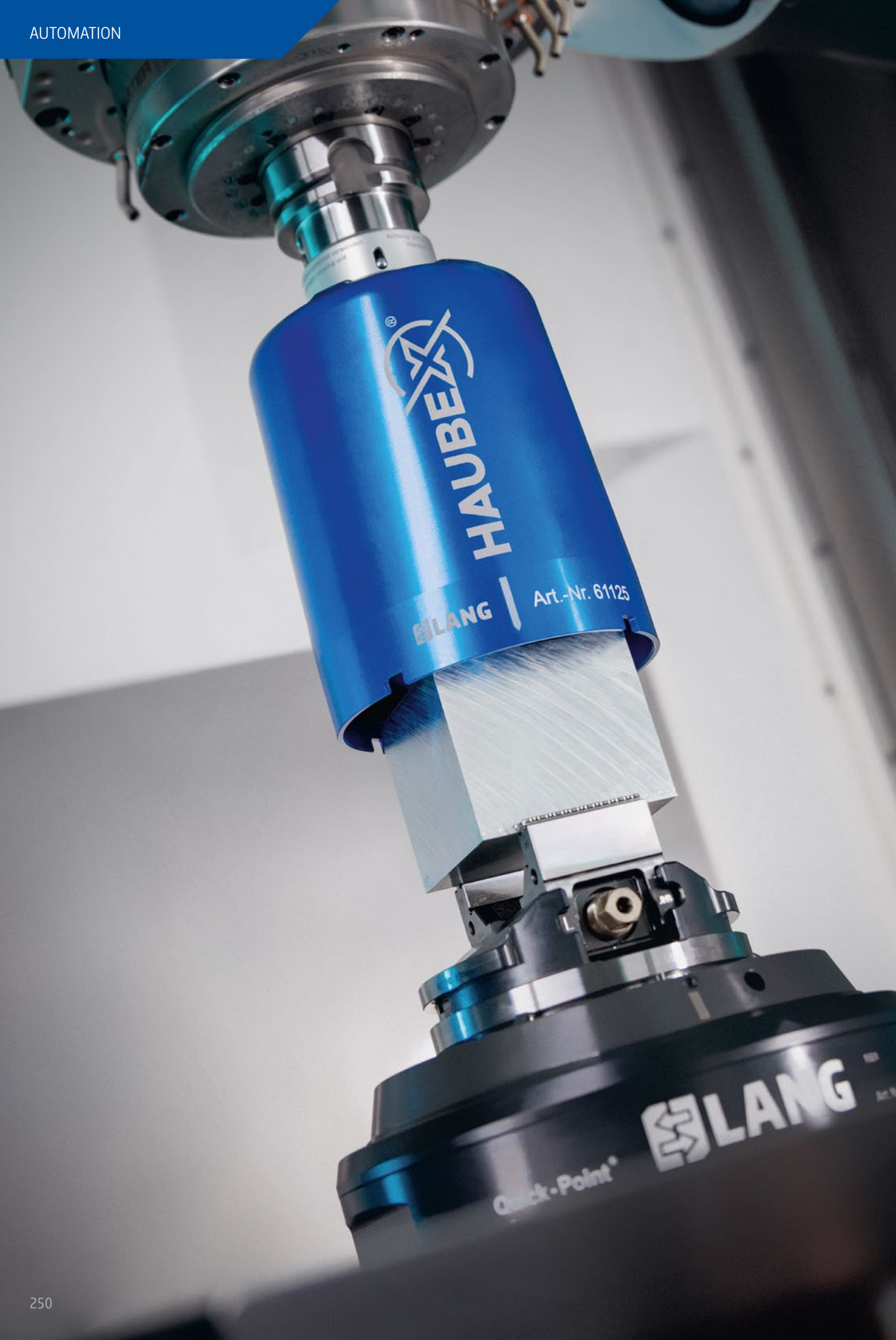

Haubex

automation system

Haubex is a flexible and cost-effective automation solution for small batches starting from 2 pieces on up, transforming the tool magazine into a storage system which does not require an additional racking system or robot. The heart of Haubex is a workholding hood that serves as a carrier system for clamping devices and workpiece blanks. It is called up via an NC program and inserted from the tool magazine. Haubex makes it easy to increase production efficiency, even on older machines. Breaks can now be filled productively, additional working time windows are created for alternative activities by the machine operator and the core working time can be extended by allowing the machine tool to continue unmanned production after the end of work.

Primary area of application:

- **Automated production**
- **Small series**
- **Small parts**

Benefits:

- **No additional space required next to the machine tool**
- **Generate additional machine hours with little effort and low investment costs**
- **Flexible application options, as not tied to a specific machine tool**

Haubex

Tool holder:

- Tool holders specially adapted to Haubex of the type:
HSK-A63, SK-40, BT-40, CAT-40

Workholding hood:

- made of high-strength aluminium
- collision buffer between tool holder and workholding hood
- integrated vise fastening and guidance

Vise:

- Haubex-specific 5-axis vise with Makro·Grip® technology
- jaw width 46 mm, clamping range up to 65 mm
- slim, compact design
- maximum workpiece size 80 × 75 × 70 mm
- zero point interface

Zero point clamping system:

- patented clamping mechanism
- open/close by rotating workholding hood on the clamping device by 90°
- alternatively, using a clamping lever in manual operation
- equipped with Quick·Point® 96 clamping studs



ZERO POINT CLAMPING

WORKHOLDING

AUTOMATION

Workpiece clamping

Workpiece blanks with dimensions of approx. 80 × 75 × 70 mm can be clamped in the Makro-Grip® Haubex 5-axis vise by form-fit. With a maximum tightening torque of 60 Nm, the 5-axis vise achieves holding forces of up to 14,000 N. Thanks to the defined form-fit between the pre-stamped workpiece and the jaw serration, the Makro-Grip® technology guarantees absolute process reliability and repeatability.



Equipping the workholding hood

The Haubex set-up station offers an uncomplicated and quick way to prepare the workholding hood for automated use. Alternatively, the workholding hood can also be equipped with the 5-axis vise without a set-up station, e.g. by positioning the workholding hood in a tool setting device.



Measuring and program sequence

Measuring the z-height on the tool setting device and entering it in the program. Sample specifications for NC programs for setting up the automatic vise change can be downloaded from our website.



Vise storage

The workholding hood equipped with the clamping device and workpiece blank is placed in the tool magazine like a common tool by the operator. Alternatively, the vise and workpiece blank can be placed into the zero point clamping system and picked up by the workholding hood already inserted in the tool magazine.



Clamping mechanism

The workholding hood places the 5-axis vise into the zero point clamping system and locks it by a 90° closing movement. Alternatively, the zero point device can be actuated via a clamping lever during manual operation without the Haubex system.



Cleaning

After the machining process and prior to the automatic removal through the workholding hood, we recommend cleaning the machine interior and all important interfaces with the Clean·Tec chip fan.



HAUBEX workholding hood

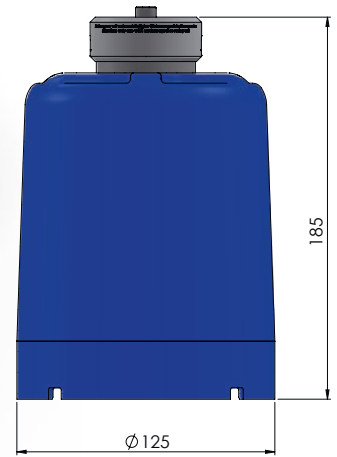

HAUBEX WORKHOLDING HOOD

ITEM NO.	LOWER DIAMETER	MAX. WORKPIECE SIZE	WEIGHT	TOTAL HEIGHT *
61125	Ø 125 mm	approx. 80 × 75 × 70 mm	1.0 kg	185 mm

* Including safety element.

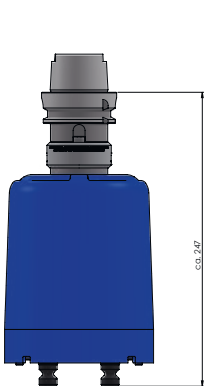

Workholding hood with HSK-A63



Workholding hood with SK 40



Workholding hood with BT 40

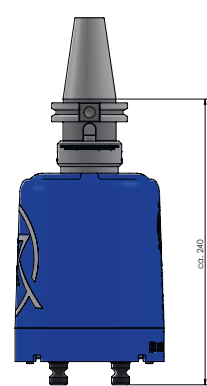

Workholding hood with CAT-40

HAUBEX tool holders

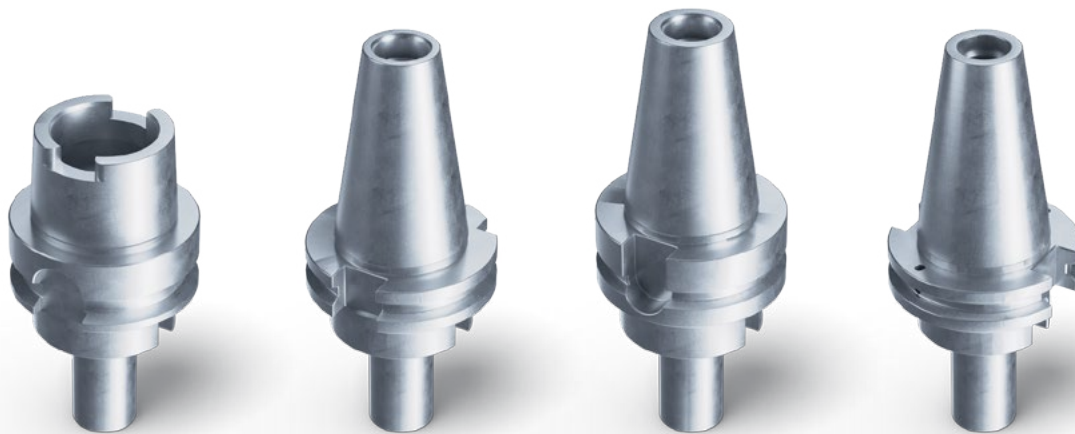

HAUBEX TOOL HOLDER

ITEM NO.	TYPE	STANDARD	WEIGHT	TOOL LENGTH *
61500-HSK63	HSK-A63 (Hollow taper shank)	DIN 69893-1	0,9 kg	approx. 247 mm
61500-SK40	SK-40 (Steep taper)	DIN ISO 7388-1	1,1 kg	approx. 240 mm
61500-BT40	BT-40 (Steep taper)	JIS B6339	1,3 kg	approx. 250 mm
61500-CAT40	CAT-40 (Steep taper)	ANSI / ASME B5.50 AD/B	1,1 kg	approx. 240 mm

* Including workholding hood and Makro-Grip®. Measured to the lower edge of the clamping studs of the 5-axis vise.

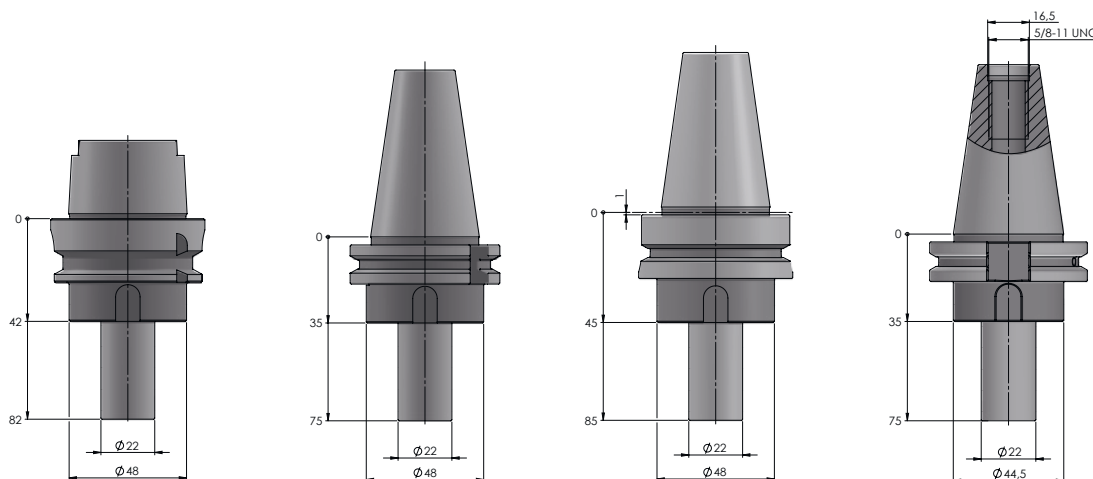

HAUBEX components

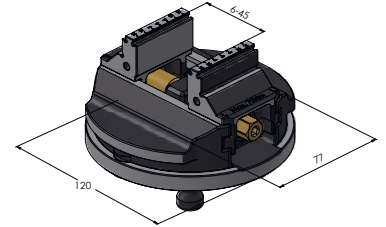
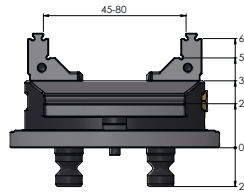

MAKRO-GRIP® HAUBEX 5-AXIS VISE

ITEM NO.	DIMENSIONS	CLAMPING RANGE	WEIGHT
61085-46	Ø 120 × 65 mm	0 – 80 mm	2.6 kg

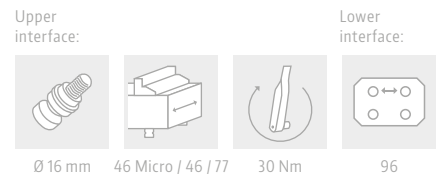
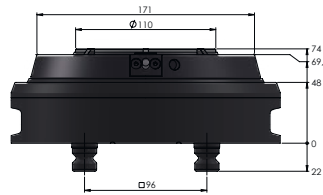

QUICK-POINT® HAUBEX ZERO POINT CLAMPING SYSTEM

ITEM NO.	DIMENSIONS	GRID SIZE	WEIGHT
61110	Ø 211 × 74 mm	52	8.9 kg

Includes: Clamping lever and cover plug remover

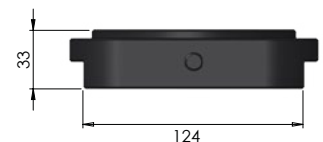
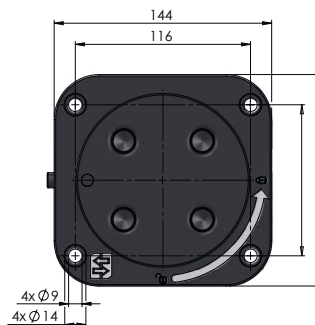

HAUBEX SET-UP STATION

ITEM NO.	DIMENSIONS	GRID SIZE	WEIGHT
61115	144 × 144 × 33 mm	52	1.5 kg

Applications

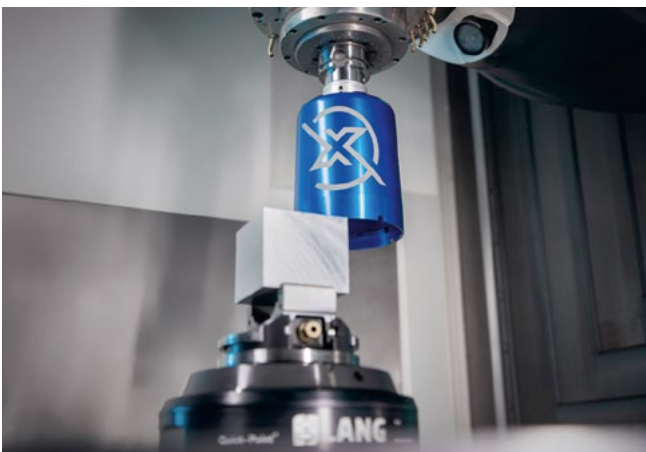
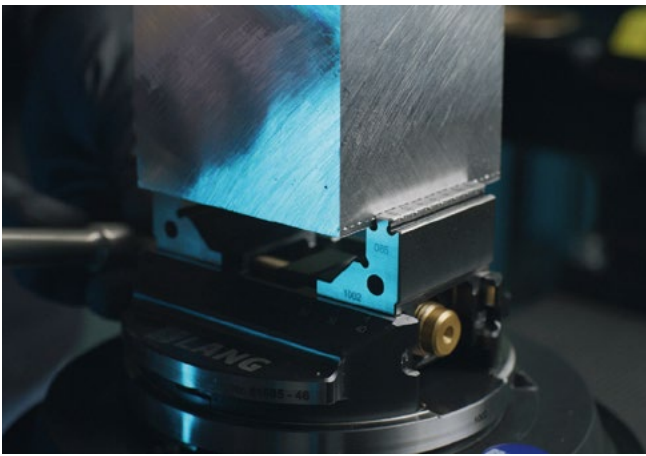

ZERO POINT CLAMPING

WORKHOLDING

AUTOMATION



Clean·Tec

chip fan



The Clean·Tec chip fan cleans the inside of the machine and removes chips and coolant without the operator needing to open the machine door. It thus enables automatic in-process cleaning of workpieces and fixtures after the machining process. It is called up via the machine program and exchanged from the tool magazine just like a regular tool. The Clean·Tec opens and closes its blades by controlling the speed of the machine spindle. It is an indispensable tool, particularly in automated production. Before the automatic removal, it cleans all critical interfaces between the clamping devices, thus ensuring a clean and flawless process.

Primary area of application:

- **Automated cleaning in closed machines**
- **Can be used after the end of each machining cycle**
- **Suitable for all clamping situations and components**

Benefits:

- **Increased operator safety and no carry-over of chips to the outside**
- **Energy savings and no need for expensive compressed air**
- **Consistent cleaning quality and ideal for unmanned, automated production**

Clean•Tec

Chip fan:

- three different sizes (Ø 160 mm, Ø 260 mm, Ø 330 mm)
- four carbon fibre blades per chip fan
- retaining springs for controlled opening / closing of the blades
- glass fiber body with steel core
- integrated bore for internal coolant supply
- slim design for space-saving storage in the tool magazine

Matching tool holder:

- for every standard tool holder Ø 20 mm (except shrink fit chucks)
- also available for 3/4" tool holders





Automated in-process cleaning after CNC machining



Clean, safe, economical

The use of the chip fan enables companies to reduce the amount of costly compressed air that is usually used when cleaning machines manually with a compressed air gun. Especially in times of increasing energy costs, this opens up considerable savings potential for companies. At the same time, automatic in-process cleaning with the machine door closed increases work safety, as the operator does not get involved in the cleaning process and is protected from chips flying around. The Clean·Tec keeps the workplace clean – after all, chips should end up on the chip conveyor, not in front of the machine.

A must-have in automation

The rapid developments in automation technology are also significantly increasing the relevance of automated cleaning within machine tools. Before the handling system or robot performs the automatic removal of the clamping device or pallet, the Clean·Tec cleans the clamping device, workpiece and machine table as the final step in the machining process. Due to its decisive contribution to trouble-free machining and changeover cycles, the Clean·Tec chip fan is an indispensable tool in automation.



Zerspanungstechnik Pareth GbR

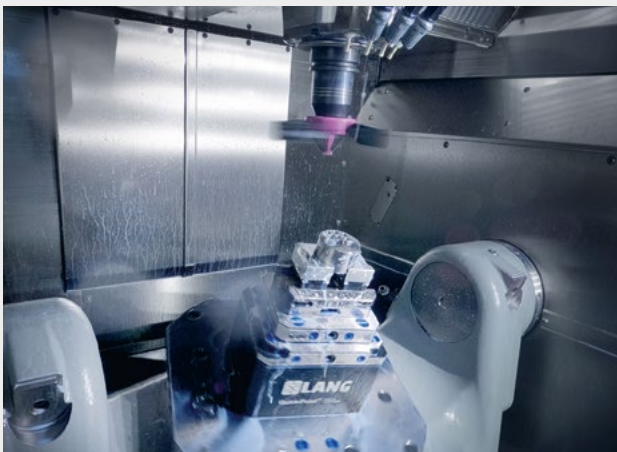

Time for a change!

With its characteristic "whirring" sound, the Clean·Tec signals that the machining of a workpiece is nearly complete. Especially for machine tools that are not automated and where the parts are changed manually, the acoustic signal supports the machine operator, who may not be in the immediate vicinity of the CNC machine. This allows them to reach their machine in good time and avoid losing valuable time. The volume depends on the spindle speed and the size of the machine's workspace (the smaller the space, the quieter the sound), but always remains pleasant to the ear.

From the tool magazine to the CNC machine

The chip fan is stored in the tool magazine like a normal tool and is called up via the NC program as the final work step in the machining cycle. The Clean·Tec fits into any commercially available tool holder with $\varnothing 20$ mm (except shrink-fit holders). Thanks to its slim design and space-saving construction of only $\varnothing 68$ mm (when folded), the magazine pockets directly next to the Clean·Tec can also be occupied with tools. Stable retaining springs ensure that the blades of the chip fan fold in completely.

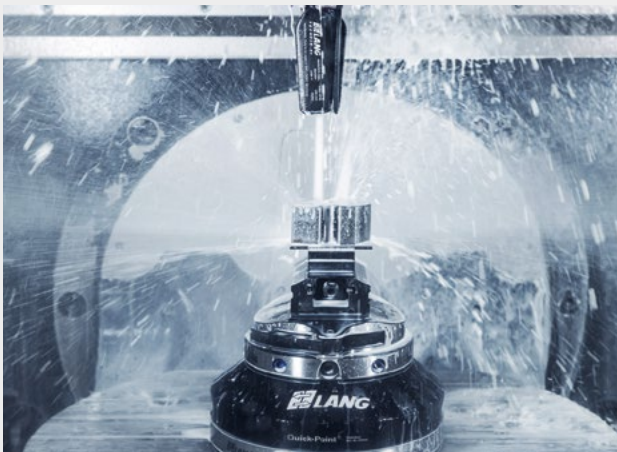
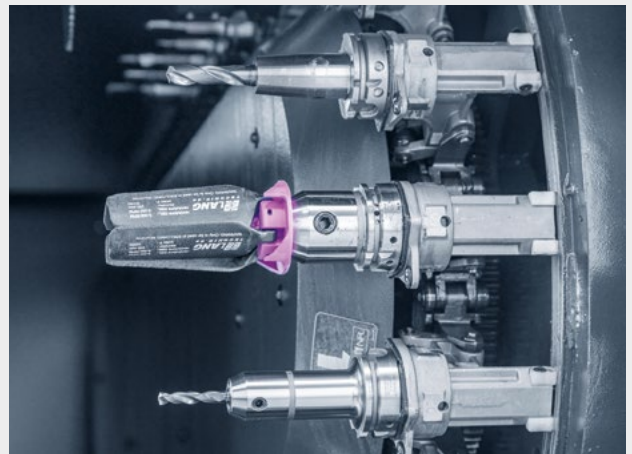

Pre-cleaning by rinsing

An integrated channel through the steel core of the glass fiber body makes it possible to thoroughly rinse workpieces and devices before the actual cleaning process. This pre-cleaning technology is not only intelligent, but also extremely effective, as it significantly increases the cleaning effect. This method is particularly useful for pocket bores, where chips are often stuck and difficult to remove.

Functionality and application

Functionality

Opening and closing the blades by controlling the machine spindle speed

Acceleration

Recommendation: in two steps. First to 2,000 rpm, then to the desired top speed

Distance to the workpiece

approx. 100 – 150 mm

Feed rate

3 – 10 m/min



DID YOU KNOW THAT...?

Together with the Vario·Tec pin jaw technology, the chip fan is one of our first and oldest products and has now been on the market for over 25 years. This revolutionary approach at the time and a certain "out-of-the-box" way of thinking contributed to the Clean·Tec becoming a lasting success and enjoying great popularity worldwide today. The Clean·Tec also stands for the innovative strength of our company, which has been followed by numerous other market-defining technologies.

Clean·Tec Chip Fan

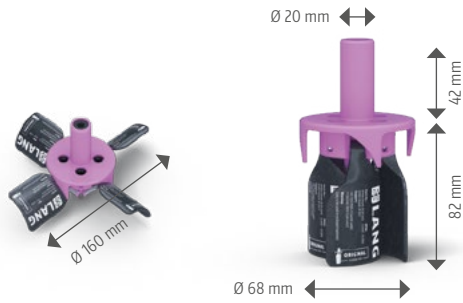

CLEAN·TEC 160

ITEM NO.	Ø WITH OPEN BLADES	RPM RANGE
30160	160 mm	6,000 - 12,000 RPM

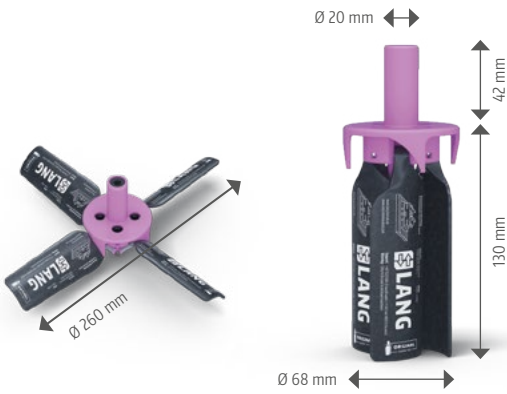

CLEAN·TEC 260

ITEM NO.	Ø WITH OPEN BLADES	RPM RANGE
30260	260 mm	5,000 - 8,000 RPM

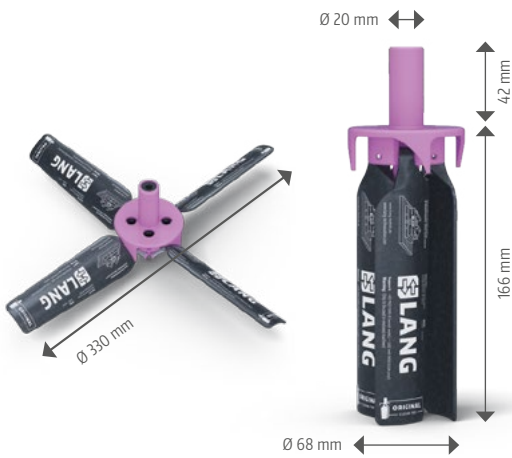

CLEAN·TEC 330

ITEM NO.	Ø WITH OPEN BLADES	RPM RANGE
30330	330 mm	3,000 - 8,000 RPM



CLEAN·TEC SPARE PART KIT

ITEM NO.	FOR
30164	30160
30264	30260
30334	30330

Included in delivery: 4 blades, 4 springs, 4 pins.

LANG Technik supports **BILD hilft e.V. “Ein Herz für Kinder”**



As a family owned company, we think in generations. For this reason, we have for years supported different projects that sponsor and strengthen our next generations. One of those is the Bild hilft e.V. “Ein Herz für Kinder” campaign founded by the Axel Springer Verlag in 1978. For the last ten years we’ve donated 2 € with every Clean·Tec fan sold. Up to this date, we’ve collected more than 120,000 € for children in need.

BILD hilft e.V. “Ein Herz für Kinder”

We want every child to have a chance.

BILD hilft e.V. ‘Ein Herz für Kinder’ is one of the best-known aid organizations in Germany, working nationally and internationally for children in need. Needy children receive food, clothing, furniture and learning materials. Schools, kindergartens and hospitals are supported in their construction or expansion. For several years, the association has been particularly active in advancing medical research, for example in the fight against rare childhood diseases or particularly aggressive types of cancer. In addition, “Ein Herz für Kinder” has recently been increasingly supporting educational projects to improve opportunities for disadvantaged children.

We want every child to have a chance – regardless of their background, religion or skin color. This means that “Ein Herz für Kinder” provides help as directly and immediately as possible. Every cent of a donation goes where it is needed – to children in need. Half of the financial aid goes to Germany, the other half goes abroad.

For more information, visit our website www.ein-herz-fuer-kinder.de or our social media channels:



With every Clean·Tec fan sold, 2 Euros will be donated to the BILD hilft e.V. “Ein Herz für Kinder” foundation.

**@einherzfuerkinder
on facebook**

**@einherzfuerkinder
on instagram**

**@BILDhilft
on X**

Online Shop

Ask for your individual quote through our website

All LANG items can also be found on our website. There you have the option of adding items to your shopping cart and sending us an inquiry. This will be forwarded directly to our sales partners in the respective country, from whom you will receive an official quote.

Further information can be found on

www.lang-technik.de

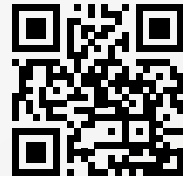

Scan here!

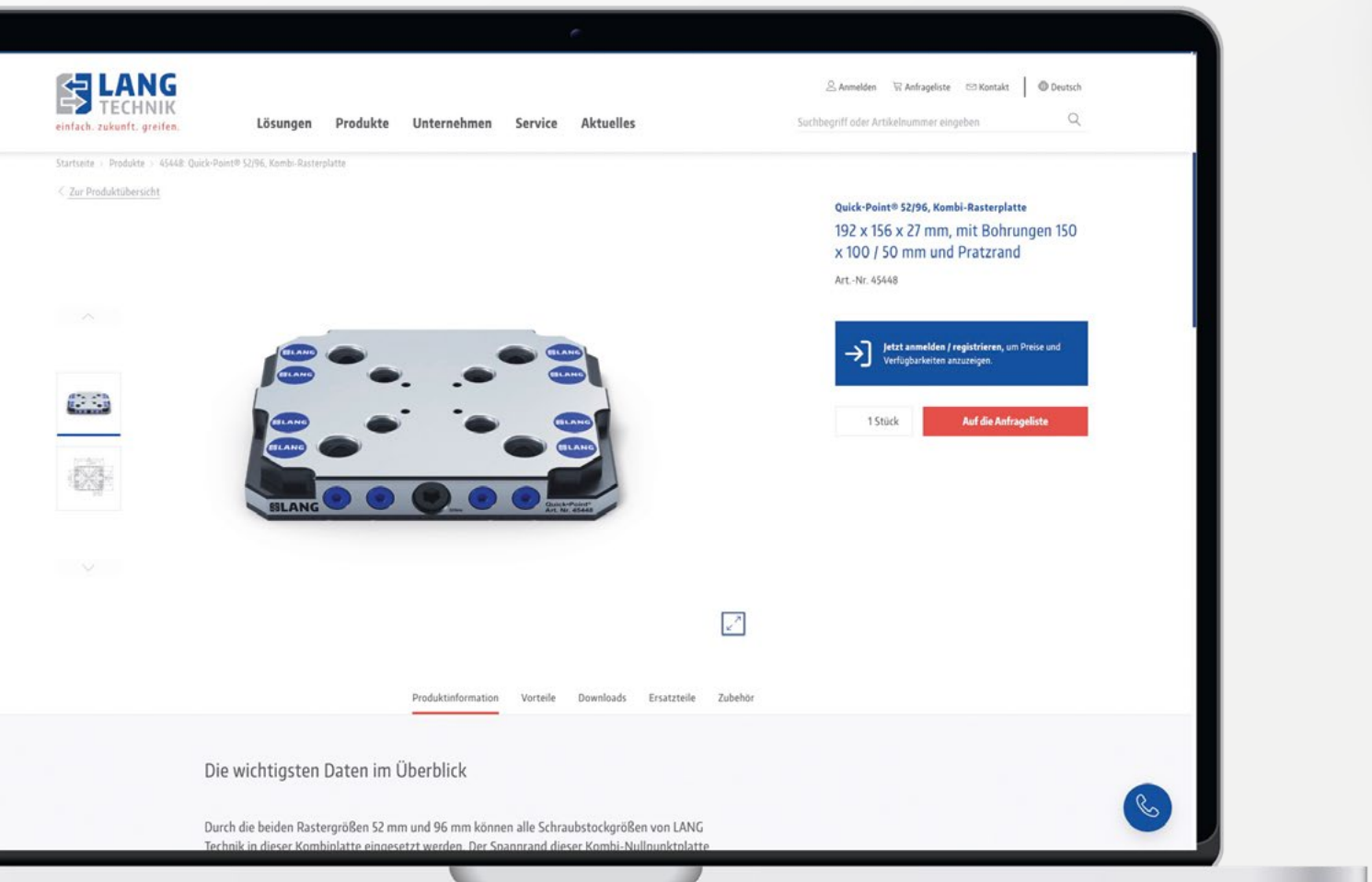



LANG live your style!

Your new favorite pieces from our store

In the LANG Brand Store, you'll find mega outfits that will give you the best look for work, sport or hanging out. Plus cool gadgets that simply put you in a good mood! All day LANG.

@langtechnik #langstyle



Shop the
LANG look

Terms & Conditions

Offer validity

Our offers are valid for 45 days and may be revoked by us at any time thereafter.

Prices

Prices are ex works, excluding packaging, transport, customs and plus the statutory value added tax. This shall also apply in the case of agreed partial deliveries and express deliveries.

Minimum order value

The minimum order value is € 30.00 net. In the case of a lower order value, the minimum amount of € 30.00 plus statutory value added tax will be charged.

Reservation of ownership

The delivered goods remain our property until full payment of the purchase price and can be reclaimed at any time, in which case the costs for this will be invoiced.

Incorrect order / return

Returns are possible up to a maximum of four weeks after receipt of the goods. The returned goods must not show any signs of use. If goods are returned with visual damage, restocking costs amounting to 20% of the value of the goods will be charged.

You can find the complete terms & conditions on our website www.lang-technik.de.

Imprint

Titel:

LANG catalog 2025/2026

Date of printing 12/2024

Editor:

LANG Technik GmbH

Albstraße 1 – 6

D-73271 Holzmaden

Phone: +49 7023 9585-0

Fax: +49 7023 9585-100

www.lang-technik.de

info@lang-technik.de

Legal provisions:

Copyright © 2024

LANG Technik GmbH

All rights reserved. Reprint, recording in online-services, internet and duplication on data carrier as CD ROM, DVD, etc. or in extracts are prohibited. Misprints, errors and changes are subject to modifications. All indications of weight are approximate values. Illustrations can vary from articles.

Symbols

To simplify specifications we use these symbols to highlight technical information and the compatibility of the products:



Grid system:
Zero point pitch



Clamping stud size:
Diameter of the clamping studs



Quick-Lock:
The fastener can be attached



Vise size:
Width of vise



Torque:
Maximum allowed torque



Clamping force:
Clamping force at maximum torque



Centering accuracy:
Centering tolerance of vises



Mounting bores:
Individual mounting bores and keyways are possible



Automatable:
Automation interface included

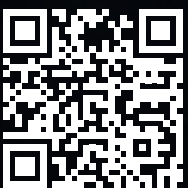

This QR code will direct you to our social media channels

